

PRIME LINE UNDERCOUNTER MULTIPURPOSE GLASS, UTENSIL AND TRAY WASHER

A heavy duty multipurpose glass, dishes, utensil and tray washer, the Prime Line dishwasher offers a simple control panel with straight forward cycle options at your fingertips. The PF46R features 4 wash cycles and durable double skinned stainless steel door.

STANDARD FEATURES

- Full stainless steel frame, tank and panels
- Colour coded status indicators - Green means Ready to start, Blue means cycle started, Red means alarm/check fault
- Soft start - cycle begins slowly to prevent glasses and crockery moving and possible breakage
- Digital temperature display
- Drain pump
- Adjustable feet supplied standard
- 1 piece deep drawn wash tank
- Inlet and waste hoses included
- Detergent dispenser & rinse aid dispenser
- Guaranteed rinse cycle only when water reaches set temperature
- Micro filter on wash pump which delivers better wash results
- Accessories include: 1 peg rack, 1 flatware rack, 1 cutlery container
- WRIS2+ Wash and Rinse Arm. Smart design delivers 25% reduction in rinse water consumption

OPTIONAL FEATURES

- Insert for bakery pans



DIMENSIONS

Dishwasher: 600W x 695D x 830H mm

Clearance: 400 mm

Rack size: 500mm x 600mm

WASH CYCLE

4 Cycles - Eco Fast (120 sec) / Glasses (180 sec) / Dishes (240 sec) / Intensive (480 seconds)

POWER SUPPLY

380 - 415V 3N 50Hz 20A Three phase no plug supplied

TECHNICAL DATA

Energy Consumption: 7.83 kW

Water Temp. Supply: 45° - 55°C

Water Connection: 2-4 bar, 3/4"

Tanks Drain: 50mm

Water Consumption: 3.2L per cycle / rack

Noise: 70 dBA

WEIGHT: 66 KG

Control Panel: Digital

SPECIFICATIONS ARE SUBJECT TO CHANGE WITHOUT NOTICE.

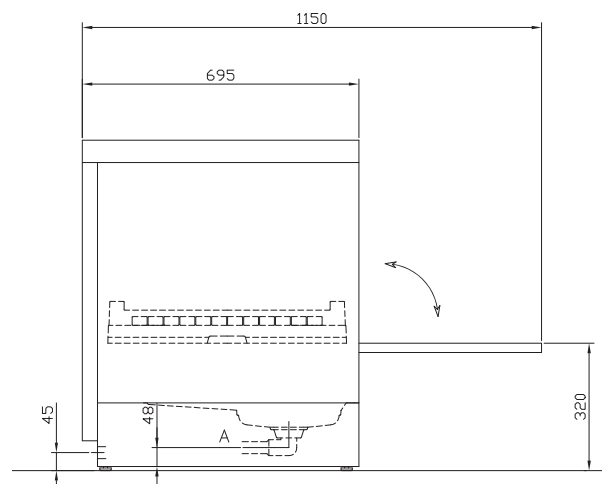
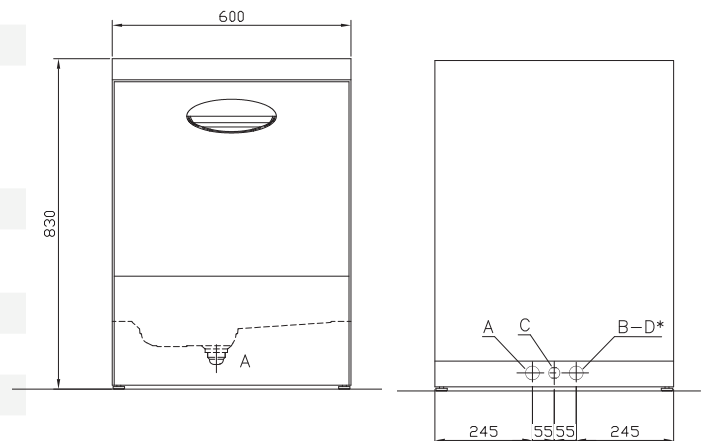

A	TANK DRAIN
B	WATER INLET 50/60°C - 2/4BAR
C	ELECTRICAL CONNECTION
D*	COLD WATER INLET 2/4BAR
*	ONLY FOR MACHINE WITH COLD RINSE