

The state-of-the-art Garland Heavy Duty Electric Series is a commercial range that has been engineered for unmatched performance and durability.

The Heavy Duty Electric Series is built to last well into the future. It is also built to suit specified requirements. Each 305mm section of this series can be customised to fit the available kitchen space and workflow.

Featuring stainless steel construction with a 87mm front 'plate rail' and 254mm backguard that matches the other Electric Series units giving a sleek clean finish and can be lined up with the 152mm high adjustable stainless steel legs.

6 all-purpose tubular electric elements in 2 sizes with the option of sealed high performance elements designed for small pot work are controlled by an infinite switch and a 600mm wide heavy duty 16mm thick thermostatically controlled griddle plate.

Large easy-to-use control knobs sit atop the fully porcelain interior standard oven that accepts full sized sheet pans in both directions on a 4-position removable rack guide, has a 4.85kW element and electro-mechanical heavy duty thermostat 66°C - 288°C and a strong adjustable door with heat resistant, cool touch door handle.

OPTIONAL FEATURES

- Additional Oven Rack
- Swivel casters with front brakes
- Convection oven base (add suffix - RC) Note: Convection oven comes standard with 2 oven racks
- Sealed high performance elements with 6-heat switch (Model SS684)
Note: Sealed elements are not available with all-purpose tubular elements. All top elements must be the same type.
- Marine equipment - storm rails for pots, oven door latch, drip tray stop and deck fasteners



SS684-24G pictured

DIMENSIONS

External Dimension: 1524W x 794D x 1190H mm

Working height: 955mm

Oven Interior : 667W x 559D x 343H mm

TECHNICAL DATA

Power supply: 415V, 3 Phase, 50Hz

Total Output: 26.45kW

Element Ratings:

Tubular Element:	165mm	216mm
	1.25kW	2.1kW
Sealed High Performance Elements:	180mm	220mm
	2.0kW	2.6kW

Griddle per 300mm section:

Standard Oven:

Convection Oven:

Shipping weight: 285kg

SPECIFICATIONS ARE SUBJECT TO CHANGE WITHOUT NOTICE.

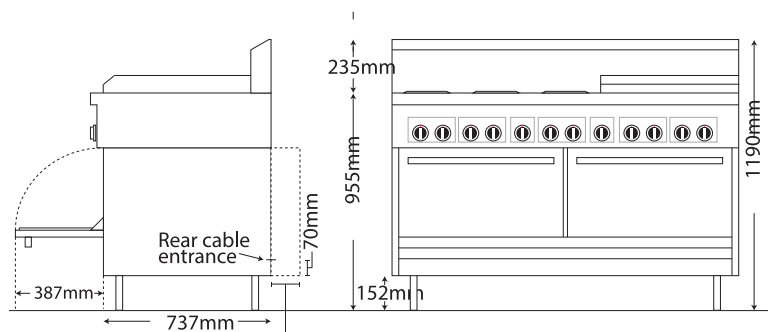
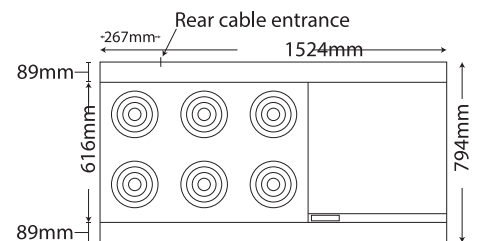

Add 127mm for optional RC motor