

Base unit constructed in AISI 304 stainless steel. Height adjustable feet in stainless steel.

OPTIONAL FEATURES

- Cabinet door

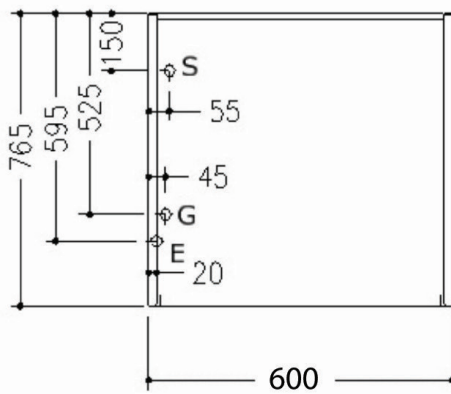
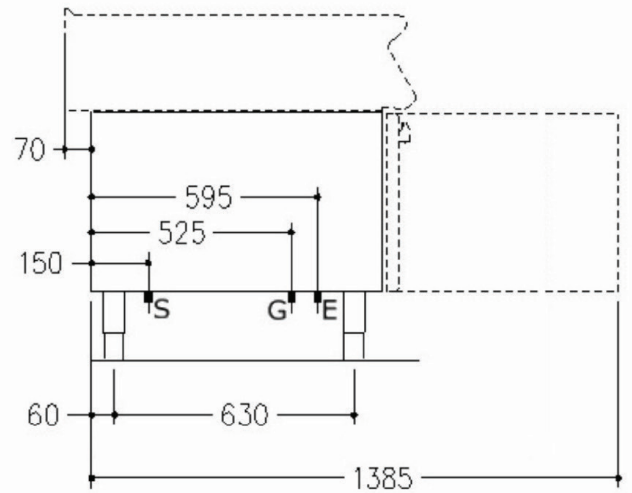
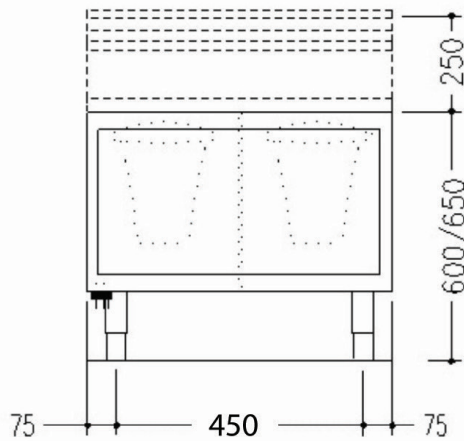

DIMENSIONS

765D x 600W x 620H mm

Weight: 11kg

SHIPPING DATA

850D x 610W x 630H mm

Shipping Weight: 13kg

SPECIFICATIONS ARE SUBJECT TO CHANGE WITHOUT NOTICE.

LEGEND

E = Socket (if required)

S = Draining (if required)

G = Gas (if required)