

Double wall hygienic H2 base unit constructed in stainless steel.
Height adjustable feet in stainless steel.

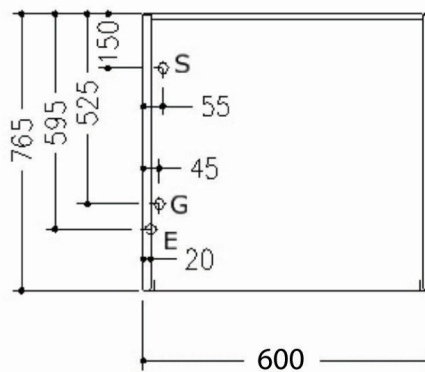
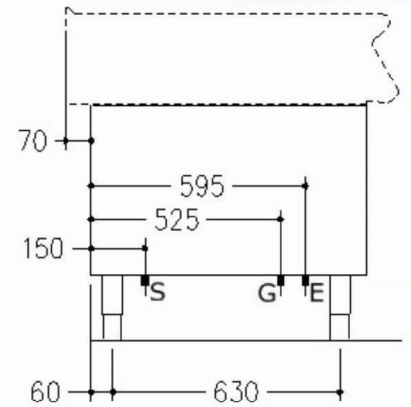
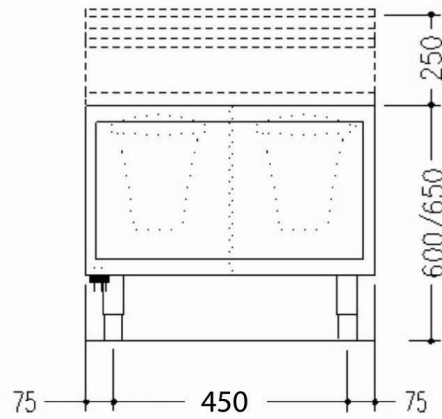

DIMENSIONS

765D x 600W x 620H mm

Weight: 27kg

SHIPPING DATA

860D x 630W x 660H mm

Shipping Weight: 29kg

SPECIFICATIONS ARE SUBJECT TO CHANGE WITHOUT NOTICE.

LEGEND

E = Socket (if required)

S = Draining (if required)

G = Gas (if required)