

Electric fry-top with two cooking zones with smooth chrome sloping hotplate, constructed in AISI 304 stainless steel. 1.5 mm thick top. Hotplate recessed 40 mm compared to worktop, fully welded construction for guaranteed ease of cleaning. Cooking surface plated with hard mirror-polished chrome with a 65 mm cold zone at the front of the hotplate. Round drain hole for grease, diam. 40 mm. Grease collection tub with 2.5 litre capacity. Heating by means of armoured elements in Incoloy. Activation of heating signalled by an indicator led on the control panel. Cooking temperature thermostatically controlled, with adjustment from 110 to 280 °C. Safety thermostat trips in the event of working thermostat malfunction. Cooking surface 735x530 mm. Scraper for smooth hotplate supplied.

STANDARD FEATURES

- 1.5mm thick pressed stainless steel tops
- Modular design
- Interlocking device supplied with all units
- Scraper for smooth hotplate supplied

OPTIONAL FEATURES

- Cabinet base and doors
- Hygienic cabinet base with pressed runners
- Refrigerated base
- 50mm stainless steel frame for worktop installed on refrigerated base or countertop

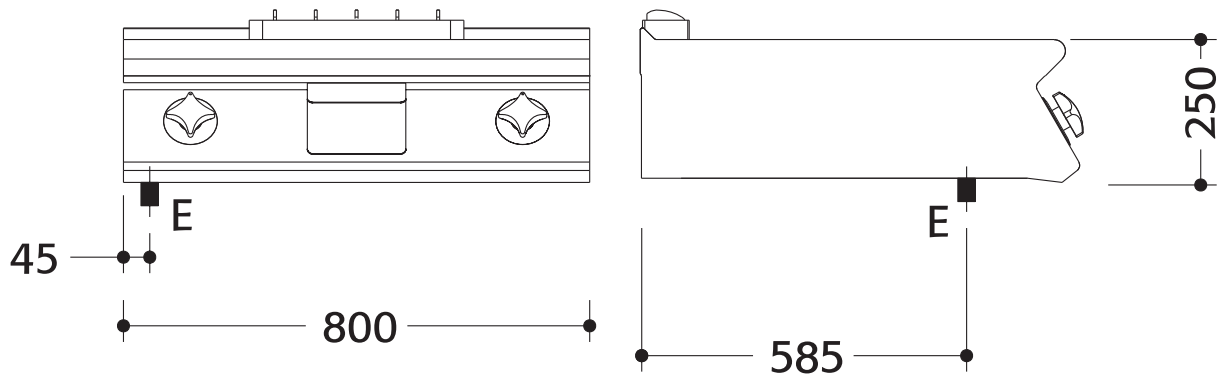

LEGEND

E = Socket

DIMENSIONS

External: 730D x 800W x 250H mm

Plate Dimensions: 530D x 735W mm

TECHNICAL DATA

Power Supply: 400V 3NAC 50Hz (Lead & Plug not included)

Total Output: 10.8kW

SHIPPING DATA

Net Weight: 77kg

Shipping Weight: 86kg

Shipping Dimensions: 830W x 840L x 550H mm

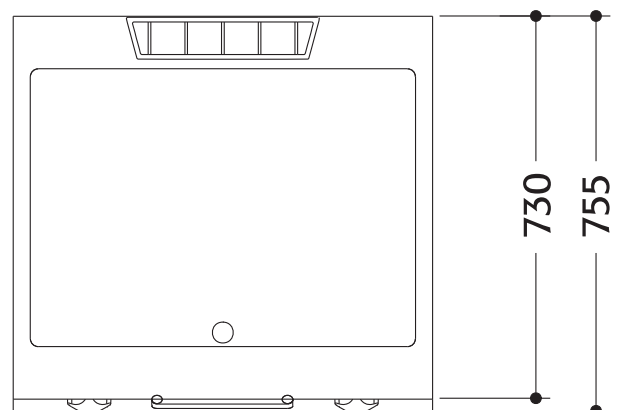

SPECIFICATIONS ARE SUBJECT TO CHANGE WITHOUT NOTICE.