

STAR 70 SERIES 800MM WIDE  
60-LITRE GAS BRATT PAN  
MANUAL TILT, STAINLESS STEEL BASE

Gas tilting bratt pan constructed in AISI 304 stainless steel. Cooking tank with manual tilt mechanism, constructed in stainless steel, 60-litre capacity, rectangular in shape with radiused corners for ease of cleaning, bottom in 10mm thick Duplex.

Designed for insertion of water filling kit operated by manual control with fixed water tap located on top. Double skinned lid with drip zone at rear for conveying condensate liquid into the pan, fitted with sturdy AISI 304 stainless steel hinges with spring balancing. Satin-finish AISI 304 tubular steel handle with front grip, joined to lid. Heating by means of steel burner with stabilized flame underneath the tank, gas safety valve with thermocouple. Automatic ignition by means of piezoelectric device with waterproof cap. Thermostatic temperature control from 100° to 280°C. Safety thermostat. Heating automatically turned off when pan is tilted. Height adjustable feet in stainless steel (850 - 900 mm).

**STANDARD FEATURES**

- 1.5mm thick pressed stainless steel tops
- Modular design
- Interlocking device supplied with all units
- Flame failure and standing pilot light
- Natural to Propane gas conversion kit
- External gas regulator supplied (specify gas type)

**OPTIONAL FEATURES**

- Castor kit
- Flexible gas hose with quick disconnect
- Water filling kit



**DIMENSIONS**

External: 730D x 800W x 870H mm

Plate Dimensions: 410D x 726W mm

**TECHNICAL DATA**

Gas Type: Natural or Propane

Total Output (Gas): Natural Gas - 55MJ/h Propane Gas - 50.4MJ/h

Gas Connection: 1/2"

Power Supply: 200 VAC-1 50/60 Hz (Cable & Plug not included)

Power Consumption (electric): 0.2kW

AGA approval number: 7412

**SHIPPING DATA**

Net Weight: 121kg

Shipping Weight: 135kg

Shipping Dimensions: 830W x 840L x 1100H mm

Tank Dimensions: 540D x 770W x 200H mm

SPECIFICATIONS ARE SUBJECT TO CHANGE WITHOUT NOTICE.

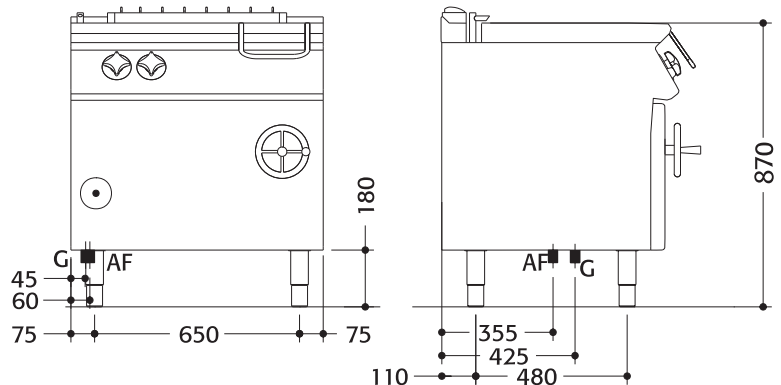
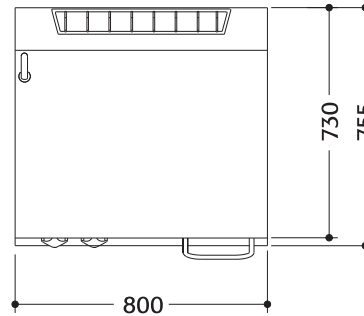

**LEGEND**

AF = Cold Water

G = Gas