

STAR 90 SERIES 1200MM WIDE  
120-LITRE GAS BRATT PAN  
MOTORISED TILT, STAINLESS STEEL BASE

Gas tilting bratt pan constructed in AISI 304 stainless steel. Cooking tank with motorized tilt mechanism, constructed in stainless steel, 120-litre capacity, rectangular in shape with radiused corners for ease of cleaning, bottom in 10 mm thick Duplex. Double skinned lid with drip zone at rear for conveying condensate liquid into the pan, fitted with sturdy AISI 304 stainless steel hinges with spring balancing. Automatic water loading operated by pushbutton. Fixed water tap located on top. Satin-finish AISI 304 tubular steel handle with front grip, joined to lid. Heating by means of steel burner with stabilized flame underneath the tank, gas safety valve with thermocouple. Electric pilot burner ignition operated by gas valve pushbutton.

Thermostatic temperature control from 100° to 280 C°. Safety thermostat. Orange indicator light on control panel indicates appliance operation. Heating automatically turned off when pan is tilted. Height adjustable feet in stainless steel. IPX5 protection rating.

**STANDARD FEATURES**

- 2 mm thick pressed stainless tops
- IPX5 water protection
- Modular design
- Interlocking device supplied with all units
- Space at rear for connections
- Flame failure and standing pilot light
- Natural to Propane gas conversion kit
- External gas regulator supplied (specify gas type)

**OPTIONAL FEATURES**

- Castor kit
- Flexible gas hose with quick disconnect



DIMENSIONS
900D x 1200W x 870H mm
Tank Dimensions: 1170 x 710 x 200H mm
Plate Dimensions: 580D x 1126W mm
TECHNICAL DATA
Gas Type: Natural or Propane
Total Output (Gas): Natural Gas - 86.3MJ/h Propane Gas - 86.3MJ/h
Gas Connection: 1/2"
Power Supply: VAC230 50Hz (Cable & Plug not included)
Total Output (electric): 0.2kW
Water Connection: 1/2" cold water
AGA approval number: 7412
SHIPPING DATA
Net Weight: 220kg
Shipping Weight: 243kg
Shipping Dimensions: 1020W x 1240L x 1100H mm

SPECIFICATIONS ARE SUBJECT TO CHANGE WITHOUT NOTICE.

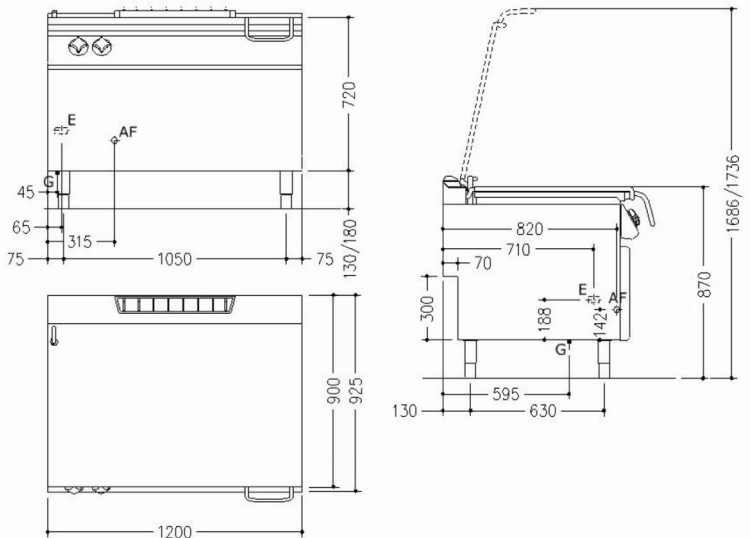

**LEGEND**

- AF = Cold Water - 1/2"  
E = Socket  
G = Gas - 1/2"