

Range cooker with gas hob constructed from AISI 304 stainless steel. 2 mm pressed top, designed for flush alignment and to accommodate the water column accessory.

Appliance comprises 4 sealed burners. Safety tap with thermocouple for continuous output control. Main burner ignition by means of permanent, low-energy pilot burner. Pilot burner and thermocouple are located underneath the main burner body, protected from accidental impact and any spills. Hob features radiused corners for ease of cleaning and pan supports in RAAF enamelled cast-iron (acid, alkali and flame resistant).

GN 2/1 gas oven with thermostatic control valve providing temperature adjustment from 50°C to 300°C. Burner with stabilized flame complete with pilot flame, safety thermocouple and piezoelectric ignition. Cooking chamber in stainless steel, dimensions 575x700x300h mm. Oven bottom in cast iron. Oven inner door in stainless steel with labyrinth seal. Appliance equipped with height adjustable feet in stainless steel (850-900 mm). IPX5 protection rating.

**STANDARD FEATURES**

- 2 mm thick pressed stainless tops
- IPX5 water protection
- Modular design
- Interlocking device supplied with all units
- Space at rear for connections
- Flame failure and standing pilot light
- Natural to Propane gas conversion kit
- External gas regulator supplied (specify gas type)

**OPTIONAL FEATURES**

- Castor kit
- Flexible gas hose with quick disconnect



<b>DIMENSIONS</b>
900D x 800W x 870H mm
Oven: 575D x 700W x 300H mm
<b>TECHNICAL DATA</b>
Gas Type: Natural or Propane
Total Output (Gas): Natural Gas - 181.5MJ/h Propane Gas - 170.8MJ/h
Burners: 4 x 37.5MJ
Gas Connection: 1/2"
AGA approval number: 7410
<b>SHIPPING DATA</b>
Net Weight: 137kg
Shipping Weight: 151kg
Shipping Dimensions: 1020W x 840L x 1100H mm
SPECIFICATIONS ARE SUBJECT TO CHANGE WITHOUT NOTICE.

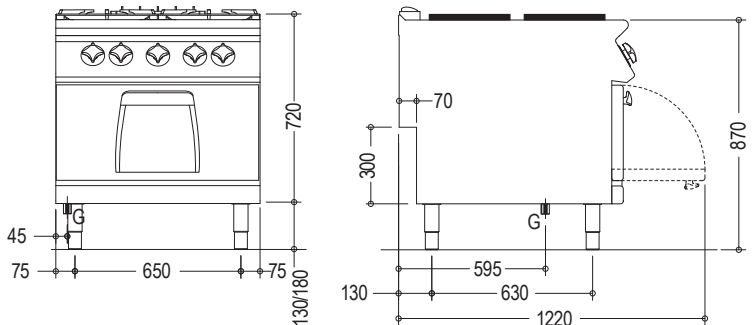
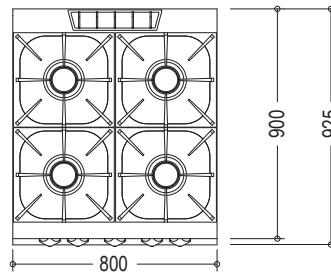

**LEGEND**  
G = Gas - 1/2"