

Single well gas fryer, constructed in AISI 304 stainless steel. 1.5 mm thick top, designed for back-to-back alignment. Pressed cooking well in AISI 304 stainless steel, with radiused internal corners. 15-litre well capacity. Well with wide front expansion zone for oil and foam and extended cold zone for collection of food particles. Heating by means of external stainless steel burners with optimized flame distribution. Heat is adjusted by means of the thermostatic safety valve with thermocouple. Main burner ignition by means of pilot burner. Piezoelectric ignition with waterproof cap on control panel. Temperature of oil in well controlled by mechanical thermostat, with adjustment from 100 to 185 °C. Safety thermostat with manual reset. Removable filter, basket, lid and catchment basin for drain tap supplied. Height adjustable feet in stainless steel (850 - 900 mm).

STANDARD FEATURES

- 1.5mm thick pressed stainless steel tops
- Modular design
- Interlocking device supplied with all units
- Flame failure and standing pilot light
- Natural to Propane gas conversion kit
- External gas regulator supplied (specify gas type)
- Removable filter, basket, lid and catchment basin for drain tap supplied

OPTIONAL FEATURES

- Castor kit
- Flexible gas hose with quick disconnect
- Dual baskets



DIMENSIONS
External: 730D x 400W x 870H mm
TECHNICAL DATA
Gas Type: Natural or Propane
Total Output (Gas): Natural Gas - 53MJ/h Propane Gas - 51MJ/h
Gas Connection: 1/2"
AGA approval number: 7411
SHIPPING DATA
Net Weight: 51kg
Shipping Weight: 61kg
Shipping Dimensions: 440W x 840L x 1100H mm

SPECIFICATIONS ARE SUBJECT TO CHANGE WITHOUT NOTICE.

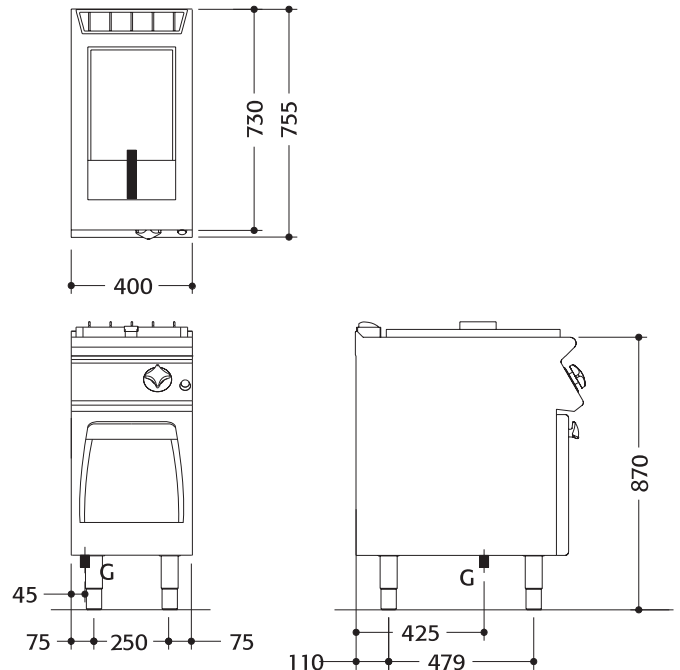

LEGEND

G = Gas