



BIN550 V DS

ICE STORAGE BIN

Stainless steel storage bin which sits underneath a range of Brema modular ice machine heads.

The BIN550 V DS stores 550kg of ice and has an insulated polyethylene moulded tank to ensure long-lasting, quality ice.

When coupled with an ice flake head, the BIN550 V DS generously stores ice to meet peak demand times for a range of applications.

Can be coupled with: TM450, G510 (x2), G1000, M350/600/800/1500.

STANDARD FEATURES

- 550kg storage capacity
- Can be coupled with a range of Brema modular ice machine heads
- Hospital grade stainless steel outer
- Polyethylene moulded tank for insulation
- Two piano-hinged door

STANDARD ACCESSORIES

- Drainage hose
- Plastic ice scoop



DIMENSIONS	
1110W x 1060D x 1915*H mm *(add 100-160mm for adjustable legs)	
Clearances: Rear: 100mm Sides: 100mm	
CONNECTIONS	
24mm Water outlet	
TECHNICAL DATA	
Storage Capacity:	550kg
Weight:	163kg
USABLE WITH MODULAR HEADS	
TM450, G510 (x2), G1000, M350/600/800/1500	

SPECIFICATIONS ARE SUBJECT TO CHANGE WITHOUT NOTICE.

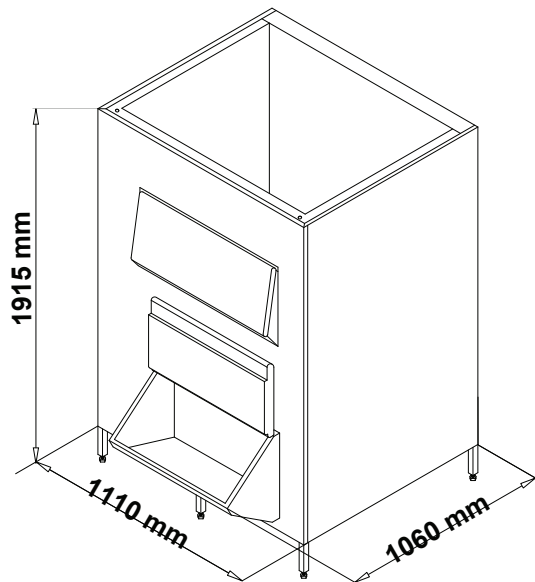

National Head Office
156 Swann Drive
Derrimut VIC 3030
Tel: +61 3 8369 4600
Fax: +61 3 8369 4699
www.comcater.com.au

Melbourne
96-100 Tope Street
South Melbourne VIC 3205
Tel: +61 3 8369 4600
Fax: +61 3 8699 1299

Sydney
20/4 Avenue of the Americas
Newington, NSW 2127
Tel: +61 2 9748 3000
Fax: +61 2 9648 4762

Brisbane
1/62 Borthwick Avenue
Murarrie QLD 4172
Tel: +61 7 3399 3122
Fax: +61 7 3399 5311

Perth
Unit 16, 7 Abrams Street
Balcatta, WA 6021
Tel: +61 8 6217 0700
Fax: +61 8 6217 0799