



Blast chiller



-18°C



Icecream



Conservation cycle



Thawing



Chilling programs



Retarder Prover



Low Cooking T°



Ozone

Features

- Thickness insulation walls 70 mm
- AISI 304 stainless steel construction
- Hot gas defrosting and Forced ventilation
- 7" Touch control
- Functions available: Blast chilling, blast freezing, Blast freezing continuous, automatic blast chilling - thawing - ice cream - conservation - retarder provers - low temperature cooking - user set programs - HACCP report alarms
- Upload and Download data with USB
- Humidification and dehumidification control algorithm



Optional

- Castor kit option
- Kit Pastry option step 10 mm
- Water condensing version
- Ozone Sanitation
- 60Hz Versions
- Network connectivity

Capacity



70 kg

+90°C → +3°C



55 kg

+90°C → -18°C

15

Trays
GN 1/1
600x800 mm

42

5 litre Pans
165x360xH120(mm)

68

Trays Pitch
(mm)

Code	CT15.2/70	CT15.2/70WCC (water cooled)
Power supply	400V/3N/50HZ	400V/3N/50HZ
Outside width	840 mm	840 mm
Depth (with handle)	1315 (1365) mm	1315 (1365) mm
Height (with castors)	1952/ 2002 (1957) mm	1952/ 2002 (1957) mm
Capacity 600x400 GN 1/1 / litres	30 / 610	30 / 610
Compressor	Semi-Hermetic	Semi-Hermetic
Output chilling (+90°C/+3°C) / (+90°C/-18°C)	70 Kg / 55 Kg	70 Kg / 55 Kg
Heating Power	1600 W	1600 W
Current absorbed / Water consumption	* 7.0 A 8.3 A	7.0 A / 198 l/h 8.3 A
Refrigeration Power (-10°C/+45°C)	7800 W	7800 W
Refrigerant gas type / Gas charge	R452A (GWP 2141)/2200 g	R404A (GWP 3922)/2200 g
Noise level	68 dBA	68 dBA
net/gross Weight	279 / 304 Kg	279/304 Kg
Shipment data (WxDxH)	880 x 1400 x 2160 mm 304 Kg	880 x 1400 x 2160 mm 304 Kg

CT15.2/70 TECNOMAC 400V-3N-50HZ - 001.ai

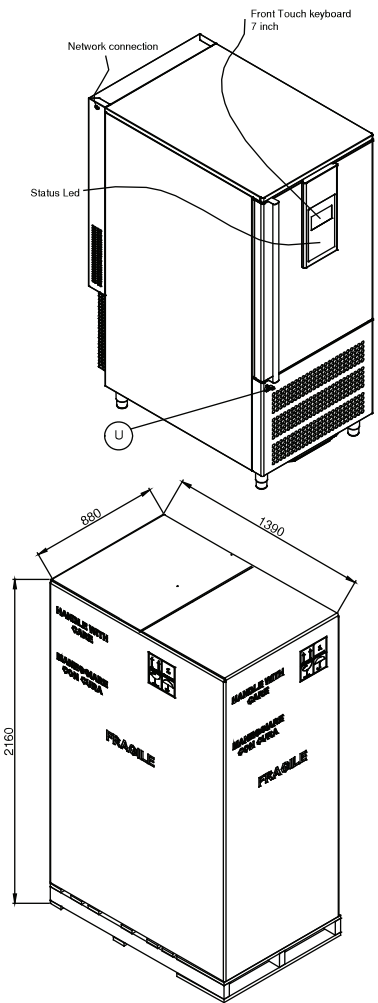
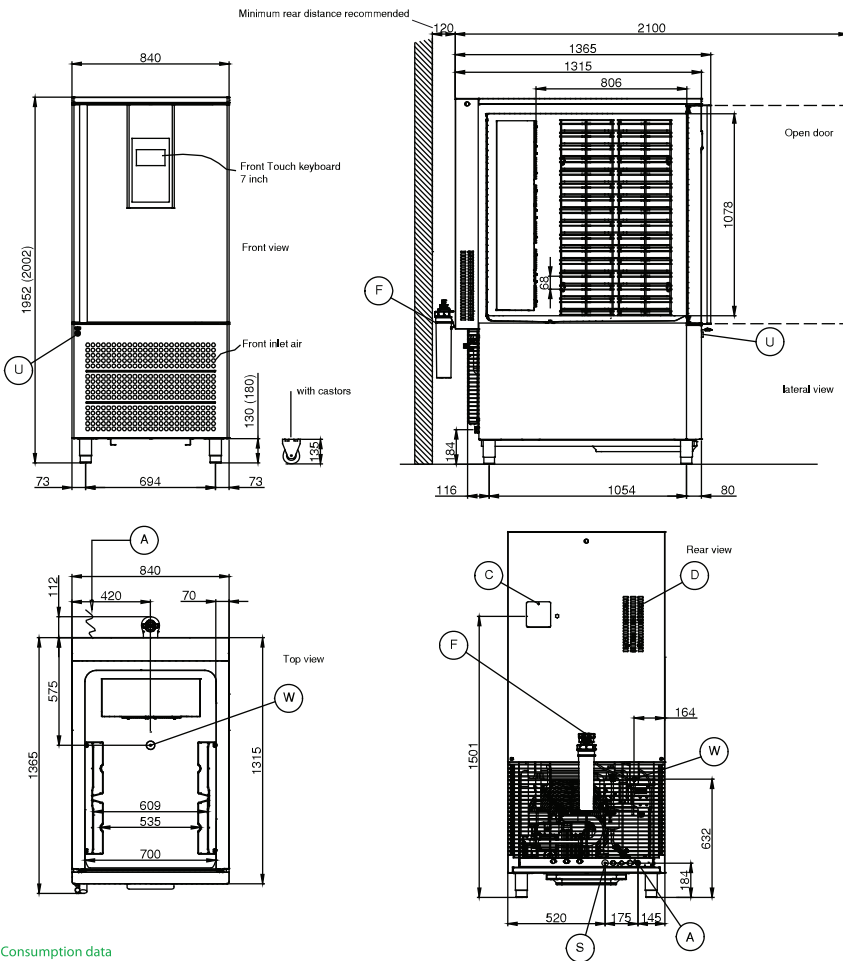

Consumption data

0,082 kWh/kg			0,271 kWh/kg		
Cycle	Duration	Down T°	Cycle	Duration	Down T°
Run	105 min	+65°C → +10°C	Run	267 min	+65°C → -18°C

- (A) Electrical cable supply
- (S) Water inlet connection 3/4" gas
- (D) Dehumidification output
- (F) Water sprayer filter
- (W) Drainage Discharge 20 mm
- (C) Cleaning sprayer access
- (U) USB connection



Functions

	Blast chiller cycles	Ice cream cycle	Conservation cycle	Retarder prover	Low T° cooking	Thawing cycles	Hot gas defrosting	Stored Programs	Ozone cycle	Variable speed fans evaporator	Variable power resistance	Dynamic Frost Control	Humidity control algorithm	Load/Download data-USB	Network connectivity
START	●	●	●	●	●	●	●	●	●	●	●	●	●	●	●
FULL	●	●	●	●	●	●	●	●	●	●	●	●	●	●	●

7" TOUCH INTERFACE

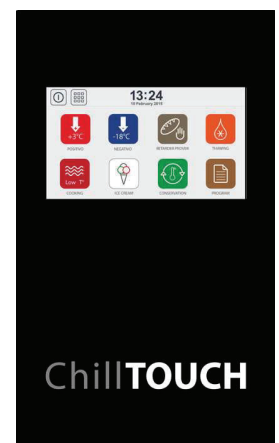

CT15.2-70 TECNOMAC 400V-3N-50HZ-001.ai