



Blast chiller



Icecream



Conservation cycle



Thawing



Chilling programs



Ozone

Features

- Thickness insulation walls 70 mm
- AISI 304 stainless steel construction
- Hot gas defrosting and Forced ventilation
- 7" Touch control
- Functions available: Blast chilling, blast freezing, Blast freezing continuous, automatic blast chilling - thawing - ice cream - conservation - user set programs - HACCP report alarms
- Upload and Download data with USB

Optional

- Ozone Sanitation
- Water condensing version
- Cover for remote condensing unit
- 60Hz Versions



Capacity

CT20 R 80



80 kg
+90°C → +3°C



65 kg
+90°C → -18°C



Rational Oven trolley

SCC201

Predisposed **WI-FI** connection



CT20 R 110



110 kg
+90°C → +3°C



95 kg
+90°C → -18°C

Features

	CT20 R / 80	CT20 R / 110
Code number		
Power supply	400V/3N/50HZ	400V/3N/50HZ
Outside length	1040 mm	1040 mm
Depth	962 mm	962 mm
Height	2275 (2040+235) mm	2275 (2040+235) mm
Max Trolley Dimensions (WxDxH)	1 Rational Trolley 2011	1 Rational Trolley 2011
Absorbed power - current	3600 W - 8A	4200 W - 13A
Output chilling (+90°C/+3°C)	80 kg	110 kg
Output freezing (+90°C/-18°C)	65 kg	95 kg
Gross Weight	340 kg	340 kg
Shipment data (WxDxH)	1210 x1090 x 2370 mm	1210 x1090 x 2370 mm

REMOTE UNIT FEATURES

Voltage	400V/3N/50HZ	400V/3N/50HZ
Refrigeration Power (-20°C/+45°C)	6500 W	8150 W
Defrost	Hot Gas	Hot Gas
Cable size (5 m included)	5 x 2.5 mm	5 x 2.5 mm
Diameter Discharge Pipe mm	12	12
Diameter Suction Pipe mm	22	22
Diameter Hot Gas Pipe mm	10	10
Refrigeration Fluid	R 452a (GWP=2141)	R 452a (GWP=2141)
Shipment data (WxDxH)	700 x 1100 x 750 mm (162 Kg)	700 x 1100 x 750 mm (170 Kg)

Dimensions

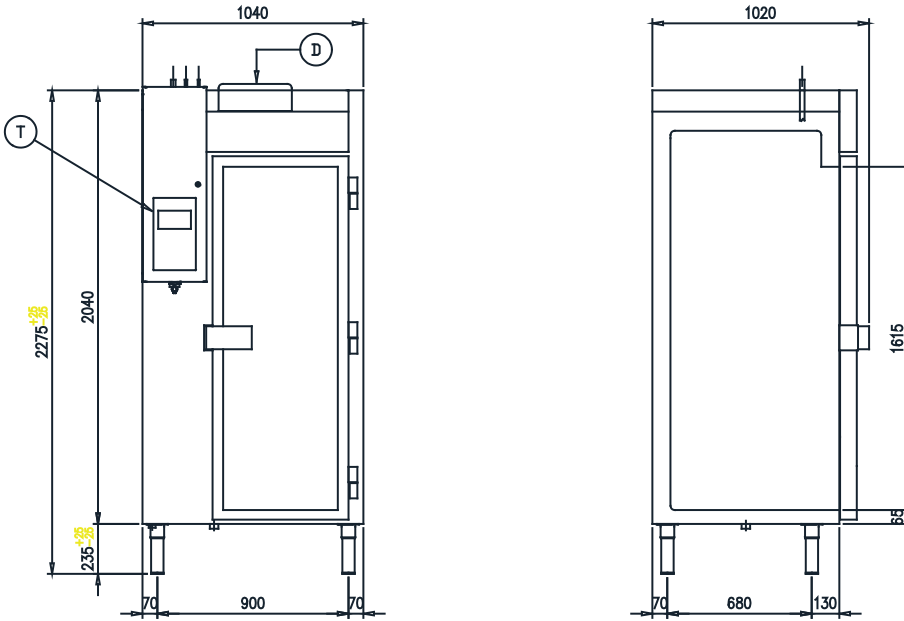

Predisposed WI-FI connection

- (A) Drainage Discharge#1'gas
- (B) Drainage Discharge#1/2'gas
- (C) Compressor Unit pipes
- (D) Electric box with power cable
- (E) WI-FI connections
- (T) 7" Touch Panel

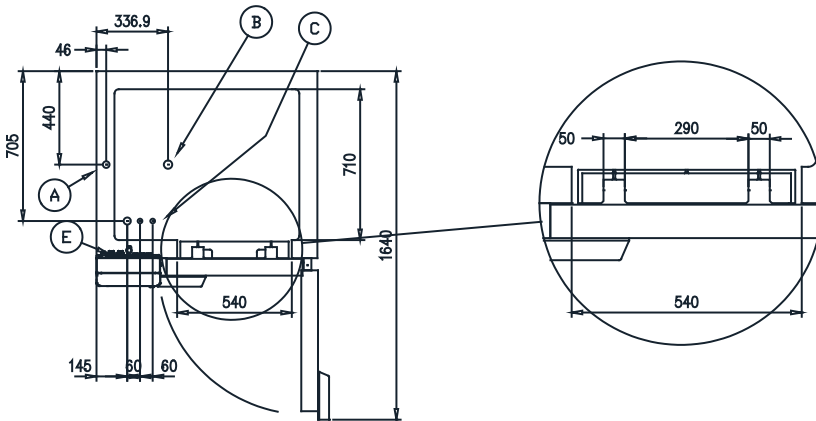

Functions

7" TOUCH INTERFACE

	Blast chiller cycles	Ice cream cycle	Conservation cycle	Thawing cycles	Ozone cycle	Hot gas defrosting	Stored Programs	Variable speed fans evaporator	Variable power resistance	Dynamic Frost Control	Load/Download data-USB
Version	↕	🍦	🔄	🌊	O ₃	💧	📄	🌿	⚡	DFC _{control}	🔌
START	●	●	●	●	●	●	●	●	●	●	●
FULL	●	●	●	●	●	●	●	●	●	●	●

