

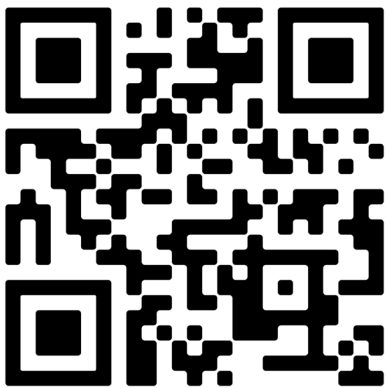

IMPORTANT! DO NOT REMOVE elastic bands on rail panels until after bottom post connector frame is installed.



SCAN HERE to watch short assembly video.

CAMBRO®



IMPORTANT! DO NOT REMOVE
elastic bands on rail panels until after
bottom post connector frame is installed.



SCAN HERE
to watch short assembly video.

Full Size

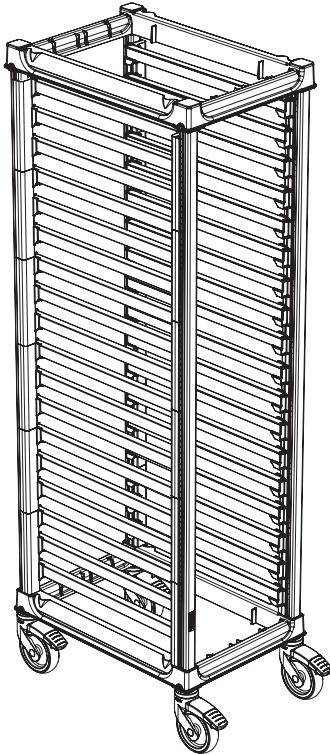

Half Size

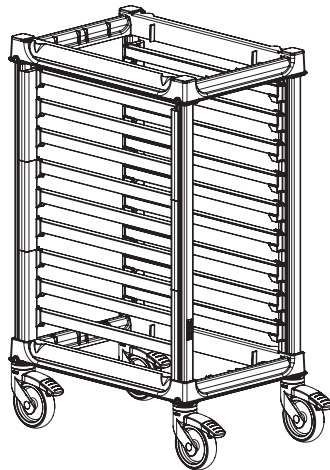

Camshelving® GN Food Pan Trolley

Parts and Tools

Post x (4)
Factory installed
Bottom Wedges and Casters

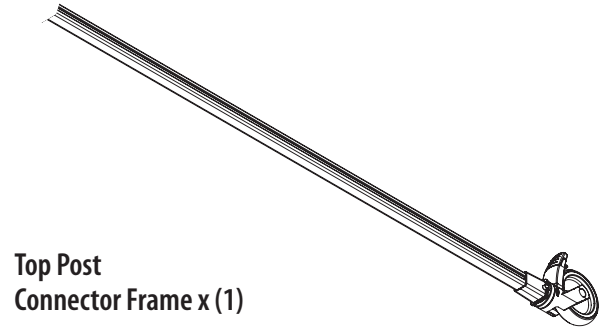

Top Post
Connector Frame x (1)

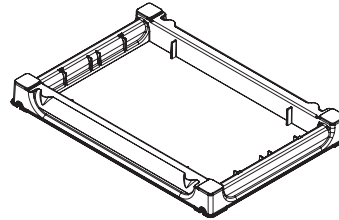

Bottom Post
Connector Frame x (1)

Wedges x (8)

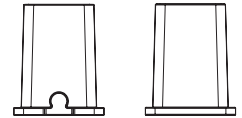

A x (4)

B x (4)

Full Size – Rail Panels x (12)
Half Size – Rail Panels x (6)

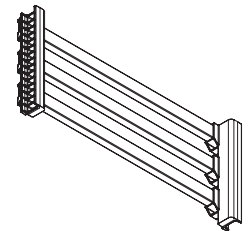
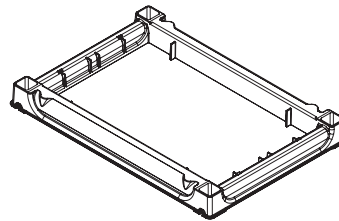

2 Person
Assembly



Use Rubber Mallet
for Assembly



COMPONENT

Step 1: Install Bottom Post Connector Frame

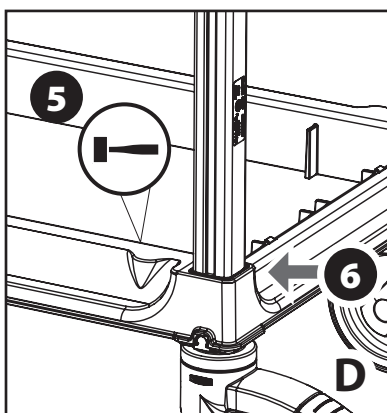
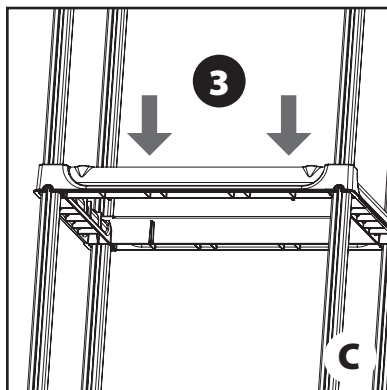
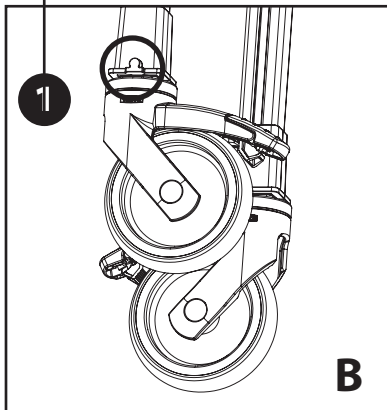
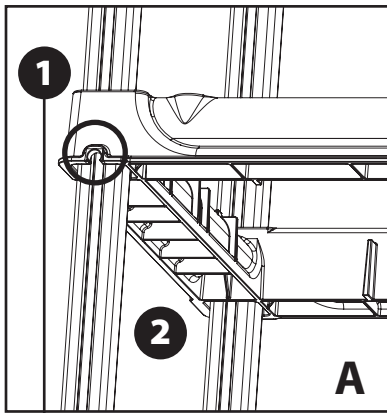

- 1** Match lock tab on post wedge (B close up) to lock opening (A close up) on frame.
- 2** Slide each post up through bottom post connector opening.
- 3** Move frame down evenly onto wedges (C close up).
- 4** Stand trolley upright on casters.
- 5** Mallet frame down on 4 corners (D close up).
- 6** Top of frame should be flush to top of wedges (D close up).

Step 2: Install Side Rail Panels

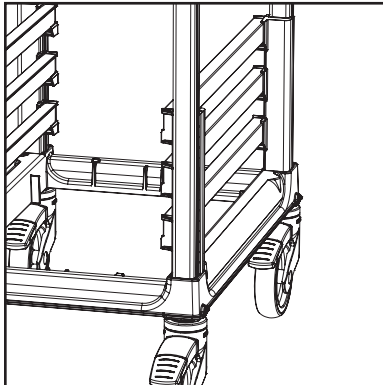
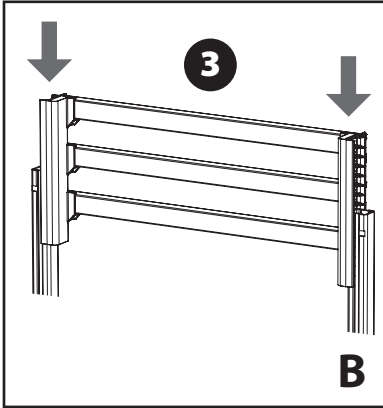
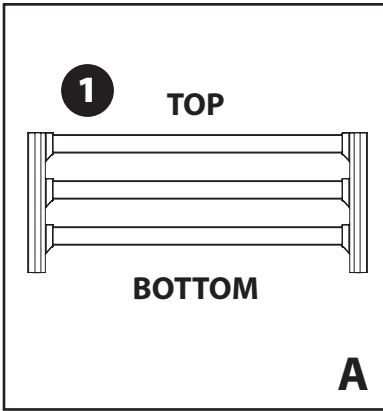

CORRECT INSTALLATION

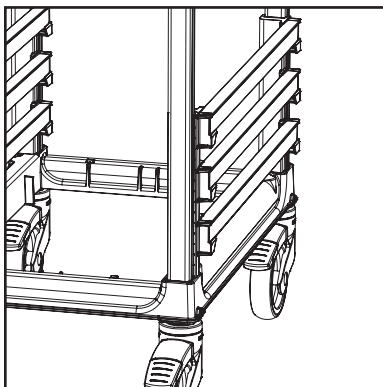

INCORRECT INSTALLATION

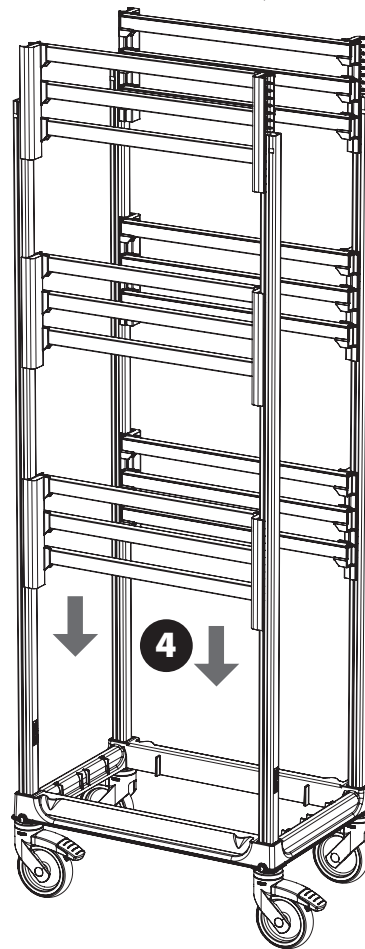

- 1** Identify top and bottom of rail panel (A close up).
- 2** Hold each side/end and carefully remove elastic band.
- 3** Hold panel with rails facing into the inside of the trolley (B close up). Slide down into grooves on posts.
- 4** Slide down slowly, 2 or 3 per side to hold frame together, alternating until complete.

Step 3: Install Top Post Connector Frame

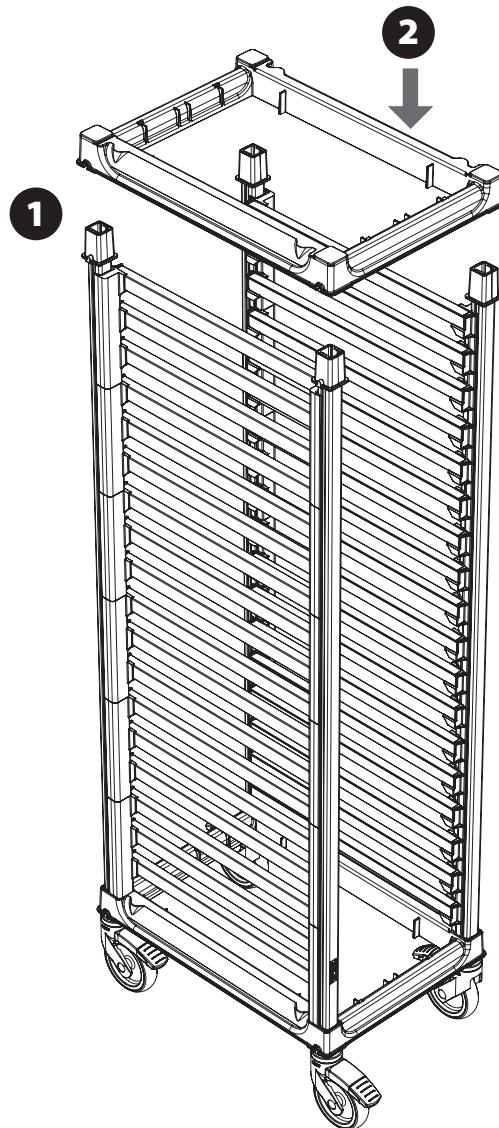
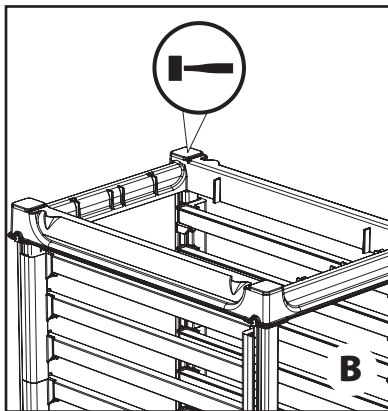
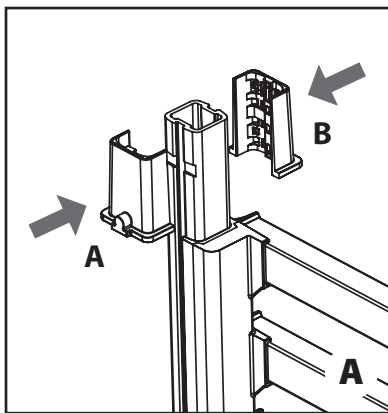

- 1** Install wedges as shown (A close up).
- 2** Place Top Post Connector Frame down onto wedges.
- 3** Mallet frame down onto each corner (B close up).
- 4** Frame lock opening should be fully engaged on wedge lock tab.

Care and Maintenance

- Clean rack and cover with hot water, mild detergent and soft cloth or sponge. Racks may also be pressure washed. Use cleaners and degreasers designated for plastic materials.
- DO NOT use cleaners or detergents containing ammonia or bleach.
- DO NOT use steel wool, abrasive scrub pads or brushes.
- Wipe off any remaining soap and dirt with a clean cloth. Allow to air dry or use a clean cloth to wipe dry.

Warranty

- GN Food Pan Trolley has a warranty against manufacturing defects for one year from date of shipment and a lifetime limited warranty against rust and corrosion.
- The warranty is in effect provided that the product has not been altered in any way and assuming normal and proper use and maintenance. Abuse or misuse will void the warranty.

Caution!

- Do not use with or place near an open flame or against hot surfaces above 177°C.
- Not intended for use in blast chiller.

Customer Service

Phone: 1300 309 262

Fax: 03 8369 4696

Email: techsupport@comcater.com.au



National Head Office
156 Swann Drive
Derrimut VIC 3026
Tel: +61 3 8369 4600
Fax: +61 3 8369 4699
www.comcater.com.au

Melbourne
96-100 Tope Street
South Melbourne VIC 3205
Tel: +61 3 8699 1200
Fax: +61 3 8699 1299

Sydney
20/4 Avenue of the Americas
Newington, NSW 2127
Tel: +61 2 8775 9500
Fax: +61 2 9648 4762

Brisbane
46-60 Dunhill Crescent,
Morningside, QLD 4170
Tel: +61 7 3900 2700

Perth
Unit 16, 7 Abrams Street
Balcatta, WA 6021
Tel: +61 8 6217 0700
Fax: +61 8 6217 0799