

**INSTALLATION & OPERATING  
INSTRUCTIONS**  
for  
**IMPINGER® CONVEYOR OVENS**  
**MODEL SERIES 1000, 1200 and 1400**



TO BE SERVICED ONLY BY AUTHORIZED PERSONS



## IMPORTANT WARNING AND SAFETY INFORMATION

**FOR YOUR SAFETY, DO NOT STORE OR USE GASOLINE OR OTHER FLAMMABLE VAPORS OR LIQUIDS IN THE VICINITY OF THIS OR ANY OTHER APPLIANCE.**

**DO NOT SPRAY AEROSOLS IN THE VICINITY OF THIS APPLIANCE WHILE IT IS IN OPERATION.**

**WARNING: IMPROPER INSTALLATION, ADJUSTMENT, ALTERATION, SERVICE OR MAINTENANCE CAN CAUSE PROPERTY DAMAGE, INJURY OR DEATH. READ THE INSTALLATION, OPERATING, AND MAINTENANCE INSTRUCTIONS THOROUGHLY BEFORE INSTALLING OR SERVICING THIS EQUIPMENT.**

- Obtain from your local gas provider and post in a prominent location instructions to be followed in the event gas odors are detected.
- It is required that the oven be placed under a ventilation hood to provide for adequate air supply and ventilation.
- Minimum clearances must be maintained from all walls and combustible materials. See spacing instruction on Page 7.
- Keep the oven free and clear of combustible material.
- Adequate clearance for air openings to the combustion control chamber on both sides of the oven is required.
- Do not obstruct the ventilation holes in the control panels, as these provide the combustion air for the burner and cooling air for the controls.
- The oven is to be operated only on the type of gas and/or electricity as shown on the specification plate.
- The power burner will not operate and gas will not flow through the burner without electrical power.
- This manual should be retained for future reference.
- The electrical wiring diagram is located under the control box covers.

## PURCHASER’S RESPONSIBILITY

It is the responsibility of the purchaser:

1. To see that the gas and electric services for the oven are installed on site in accordance with the manufacturers specification.
2. To unload, uncrate, and install the oven in its proper location; in accordance with this installation / operation manual.
3. To see that the gas and electric services are connected properly by a qualified installer of your choice. *For installation in the State of Massachusetts: Installation of this oven must be performed by a licensed plumber or gas fitter.* All such connections must be in accordance with applicable code requirements. Refer to Page 10 for specific code references.
4. To arrange for inspection and operation check-out by an Authorized Service Technician as described below:

Do not attempt to operate the oven until connection of utility service has been fully inspected by an **Authorized Service Technician** or a **Lincoln Foodservice Products, LLC Service Representative**. This service is required by Lincoln Foodservice Products, LLC in order to assist the purchaser in proper start-up of the oven on site. Please note the specific details on the Warranty and make certain connections are made to proper utility services.

**The warranty shall not apply if the oven(s) are started up and operated prior to the utilities and oven being inspected and check out made by an Authorized Service Technician or a Lincoln Foodservice Products, LLC Service Representative.**

## TABLE OF CONTENTS

WARNING AND SAFETY INFORMATION.....	2
PURCHASER’S RESPONSIBILITY.....	3
UTILITY SPECIFICATIONS – MODEL SERIES 1000 & 1200 – GAS & ELECTRIC.....	4
UTILITY SPECIFICATIONS – MODEL SERIES 1400 – GAS & ELECTRIC.....	5
MODEL NUMBER KEY.....	6
SPACING REQUIREMENTS.....	7
VENTILATION GUIDELINES.....	7
AMBIENT TEMPERATURE REQUIREMENTS.....	7
CANOPY VENTILATION RECOMMENDATIONS.....	8
GENERAL INFORMATION.....	8
UNLOADING AND UNCRATING .....	9
EXTERIOR DIMENSIONS.....	9
UTILITY SERVICE LAYOUT.....	9
CODE REFERENCE.....	10
RESTRAINT REQUIREMENT.....	10
OVEN ASSEMBLY.....	11
FINGER ASSEMBLY.....	11-12
FINGER COLUMNATING PLATES.....	12
PROGRAMMING & OPERATION – DIGITAL ADVANTAGE OVEN.....	13
OVEN OPERATION – 1000, 1200 SERIES & 1400 w/ ANALOG CONTROLS.....	14
PREVENTIVE MAINTENANCE.....	14
INFORMATION ON USE OF OVEN.....	15
OPERATOR MAINTENANCE.....	15
CLEANING INSTRUCTIONS.....	15-16
FINGER REMOVAL & DISASSEMBLY FOR CLEANING.....	16
CONVEYOR REMOVAL.....	16
CONVEYOR DISASSEMBLY FOR CLEANING & REASSEMBLY.....	16-17
IMPINGER® CONCEPTS.....	18
OVEN STACKING INFORMATION.....	18
HOW TO OBTAIN SERVICE.....	18
FUNCTIONS – THERMAL CUT-OUT SWITCH.....	18
APPENDIX A: LABEL DEFINITIONS.....	19
WARRANTY.....	20

# IMPINGER® I AND III CONVEYOR OVENS – MODEL SERIES 1000 AND 1200

## UTILITY SPECIFICATIONS REQUIRED – ELECTRIC

Model	Energy	Power	Voltage	Current	Phase	Hz	Recommended Electrical Specifications	Agency Listing
***1021-xxx-E	Electric	27 kW	400/230 VAC	40 Amps	3	50 Hz	5 Wires, 3 Poles 1N-1G	F-G
1022	Electric	27 kW	120/208 VAC	80 Amps	3	60 Hz	5 Wires, 3 Poles 1N-1G	A-B-F
1023	Electric	27 kW	120/240 VAC	70 Amps	3	60 Hz	5 Wires, 3 Poles 1N-1G	A-B-F
1028	Electric	27 kW	380Y/220 VAC	41 Amps	3	50 Hz	5 Wires, 3 Poles 1N-1G	F
1029	Electric	27 kW	415/240 VAC	38 Amps	3	50 Hz	5 Wires, 3 Poles 1N-1G	F
1032	Electric	27 kW	380Y/220 VAC	41 Amps	3	50 Hz	5 Wires, 3 Poles 1N-1G	F
1202	Electric	27 kW	120/208 VAC	80 Amps	3	60 Hz	5 Wires, 3 Poles 1N-1G	A-B-F
1203	Electric	27 kW	120/240 VAC	70 Amps	3	60 Hz	5 Wires, 3 Poles 1N-1G	A-B-F
1228	Electric	27 kW	380Y/220 VAC	41 Amps	3	50 Hz	5 Wires, 3 Poles 1N-1G	F
1229	Electric	27 kW	415/240 VAC	38 Amps	3	50 Hz	5 Wires, 3 Poles 1N-1G	F

## UTILITY SPECIFICATIONS REQUIRED – GAS

Model	Energy	Power	Voltage	Current	Phase	Frequency	Recommended Electrical Specification	Gas	Agency Listing
1030	Nat. Gas	35 kW	220 VAC	1.6 Amps	1	50 Hz	3 Wires, 1 Pole 1N-1G	35 kW/hr at 17.5 mB H <sub>2</sub> O column	F
1031	L.P. Gas	35 kW	220 VAC	1.6 Amps	1	50 Hz	3 Wires, 1 Pole 1N-1G	35 kW/hr at 27.5 mB H <sub>2</sub> O column	F
***1033-xxx-E	Nat. Gas	35 kW	230 VAC	3 Amps	1	50 Hz	3 Wires, 1 Pole 1N-1G	35 kW/hr at 17.5 mB H <sub>2</sub> O column	F-G
***1034-xxx-E	L.P. Gas	35 kW	230 VAC	3 Amps	1	50 Hz	3 Wires, 1 Pole 1N-1G	35 kW/hr at 27.5 mB H <sub>2</sub> O column	F-G
1040	Nat. Gas	120,000 BTU	120/230 VAC	5 Amps	1	60 Hz	4 Wires, 1 Pole 1N-1G	120,000 BTU at 7 inches H <sub>2</sub> O column	A-F
1041	L.P. Gas	120,000 BTU	120/230 VAC	5 Amps	1	60 Hz	4 Wires, 1 Pole 1N-1G	120,000 BTU at 11 inches H <sub>2</sub> O column	A-F
1042	Nat. Gas	120,000 BTU	230 VAC	5 Amps	1	50 Hz	3 Wires, 1 Pole 1N-1G	120,000 BTU at 7 inches H <sub>2</sub> O column	F
1043	L.P. Gas	120,000 BTU	230 VAC	5 Amps	1	50 Hz	3 Wires, 1 Pole 1N-1G	120,000 BTU at 11 inches H <sub>2</sub> O column	F
1046	Nat. Gas	126 MJ	240 VAC	5 Amps	1	50 Hz	3 Wires, 1 Pole 1N-1G	126 MJ/hr at 1.75 kPa H <sub>2</sub> O column	E-F
1047	L.P. Gas	126 MJ	240 VAC	5 Amps	1	50 Hz	3 Wires, 1 Pole 1N-1G	126 MJ/hr at 1.75 kPa H <sub>2</sub> O column	E-F
1240	Nat. Gas	120,000 BTU	120/230 VAC	5 Amps	1	60 Hz	4 Wires, 1 Pole 1N-1G	120,000 BTU at 7 inches H <sub>2</sub> O column	A-F
1241	L.P. Gas	120,000 BTU	120/230 VAC	5 Amps	1	60 Hz	4 Wires, 1 Pole 1N-1G	120,000 BTU at 11 inches H <sub>2</sub> O column	A-F
1242	Nat. Gas	120,000 BTU	230 VAC	5 Amps	1	50 Hz	3 Wires, 1 Pole 1N-1G	120,000 BTU at 7 inches H <sub>2</sub> O column	F
1243	L.P. Gas	120,000 BTU	230 VAC	5 Amps	1	50 Hz	3 Wires, 1 Pole 1N-1G	120,000 BTU at 11 inches H <sub>2</sub> O column	F

**NOTE: All ovens require separate service and dedicated neutral.**

# IMPINGER® CONVEYOR OVENS – MODEL SERIES 1400

## UTILITY SPECIFICATIONS REQUIRED – ELECTRIC

Model	Energy	Power	Voltage	Current	Phase	Hz	Recommended Electrical Specifications	Agency Listing
***1421-xxx-E	Electric	27 kW	400/230 VAC	40 Amps	3	50 Hz	5 Wires, 3 Poles 1N-1G	F-G
1452	Electric	27 kW	120/208 VAC	80 Amps	3	60 Hz	5 Wires, 3 Poles 1N-1G	A-B-D-F
1453	Electric	27 kW	120/240 VAC	70 Amps	3	60 Hz	5 Wires, 3 Poles 1N-1G	A-B-D-F
1454	Electric	27 kW	380/220 VAC	41 Amps	3	50 Hz	5 Wires, 3 Poles 1N-1G	F
1455	Electric	27 kW	415/240 VAC	38 Amps	3	50 Hz	5 Wires, 3 Poles 1N-1G	F

## UTILITY SPECIFICATIONS REQUIRED – GAS

Model	Energy	Power	Voltage	Current	Phase	Frequency	Recommended Electrical Specification	Gas	Agency Listing
***1433-xxx-E	Nat. Gas	35 kW	230 VAC	3 Amps	1	50 Hz	3 Wires, 1 Pole 1N-1G	35 kW/hr at 17.4 mB H <sub>2</sub> O column****	F-G
***1434-xxx-E	L.P. Gas	35 kW	230 VAC	3 Amps	1	50 Hz	3 Wires, 1 Pole 1N-1G	35 kW/hr at 27.4 mB H <sub>2</sub> O column****	F-G
1450	Nat. Gas	120,000 BTU	120 VAC	5 Amps	1	60 Hz	3 Wires, 1 Pole 1N-1G	120,000 BTU at 7 inches H <sub>2</sub> O column****	A-D-F
1451	L.P. Gas	120,000 BTU	120 VAC	5 Amps	1	60 Hz	3 Wires, 1 Pole 1N-1G	120,000 BTU at 11 inches H <sub>2</sub> O column****	A-F
1456	Nat. Gas	120,000 BTU	220/240 VAC	5 Amps	1	50 Hz	3 Wires, 1 Pole 1N-1G	120,000 BTU at 7 inches H <sub>2</sub> O column****	E-F
1457	L.P. Gas	120,000 BTU	220/240 VAC	5 Amps	1	50 Hz	3 Wires, 1 Pole 1N-1G	120,000 BTU at 11 inches H <sub>2</sub> O column****	E-F

	A	B	C	D	E	F	G	H
Agency Listing	CSA	UL		MEA	AGA*	NSF	CE	

### Electrical Supply for Australia:

**Single Phase:** 240VAC, 50Hz / 20 Amp: one neutral & one earth/ground.

**Three Phase:** 240/415 VAC / 20 Amp; three active, one neutral & one earth/ground.

\* AGA Australian Gas Association

\*\* In Australia, use a 10 Amp General Purpose Outlet

\*\*\* Reference Model Key

All ovens require separate service and dedicated neutral.

GAS PRESSURE CONVERSION CHART			
Inches of Water Column	KPa	m-Bar	Millimeters of Water Column
3.5	0.87	8.70	88.9
4.5	1.12	11.2	114.3
7	1.74	17.40	177.8
10	2.48	24.87	254.0
10.5	2.61	26.11	266.7
11	2.73	27.36	279.4
14	3.48	34.81	355.6
14.5	3.61	36.05	368.3

\*\*\*\*NOTE: For proper operation, the gas valve requires a nominal inlet pressure of 7 inches H<sub>2</sub>O column for natural gas and 11 inches of H<sub>2</sub>O column for L.P. gas. A minimum inlet pressure of 1.0 inch of H<sub>2</sub>O above the manifold setting (NAT. manifold 3.5" H<sub>2</sub>O, L.P. manifold 10" H<sub>2</sub>O) must be maintained with no pressure drop from the no load to full load condition. The maximum inlet pressure must be maintained at or below ½ PSIG (14.5 inches H<sub>2</sub>O column). Refer to the chart on the left for pressure conversions.

## MODEL NUMBER KEY

<u>COUNTRY</u>	<u>LANGUAGE</u>	<u>CODE</u>	<u>NOT USED</u>
1. France	French	B	A
2. Germany	German	C	I
3. Italy	Italian	D	O
4. Spain	Spanish	E	Q
5. United Kingdom	English	F	
6. Luxembourg	French	B	
7. Portugal	Portuguese	H	
8. Denmark	Danish	J	
9. Belgium	Dutch / French	K	
10. Netherlands	Dutch	L	
11. Ireland	English	F	
12. Greece	Greek	M	
13. Austria	German	C	
14. Finland	Finnish	N	
15. Norway	Norwegian	P	
16. Sweden	Swedish	R	

EXAMPLE: 1433-B00-EA

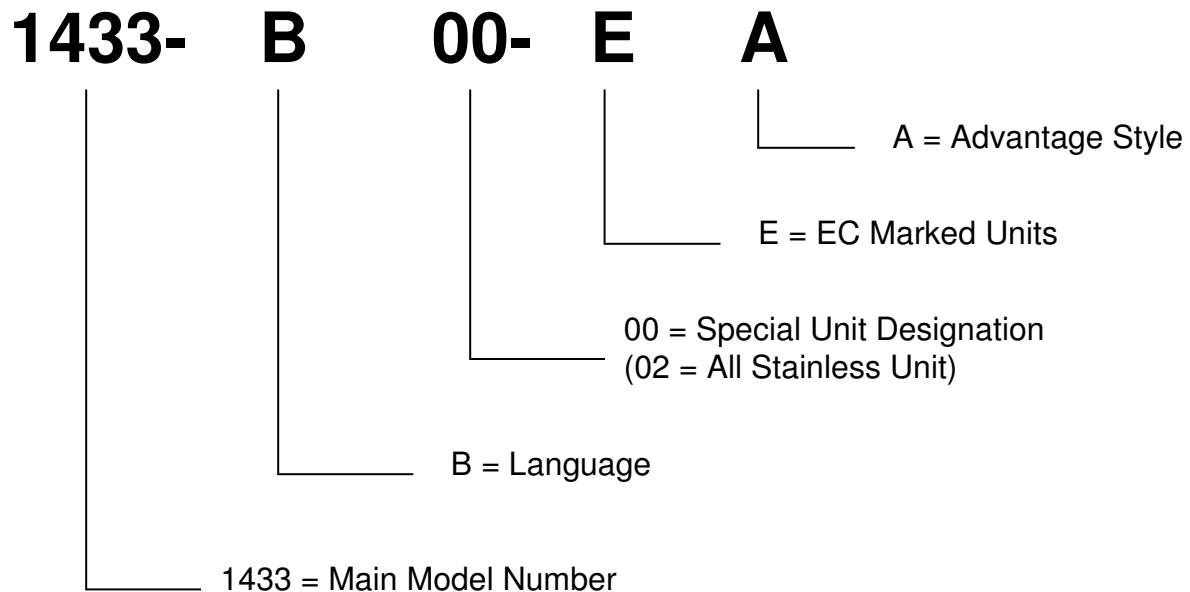

NOTE: Date of manufacture is stamped on the rating plate of each oven at the end of the serial number.

Example: XXX...01-96

## SPACING

The oven must have 5 inches (127 mm) of clearance from combustible surfaces. In case other equipment is located on the right side of oven, a minimum clearance of 24 inches (609 mm) is required from that equipment.

FOR ALL OVENS: A 24-inch (609 mm) clearance at the rear of the oven must be obtainable for service access.  
FOR 1000 and 1400 OVENS: A permanently installed (unmovable) oven requires a minimum of 11 feet clearance on the right hand side to allow for conveyor removal, cleaning, and servicing. NOTE: On 1200 Series, 11 feet on left.

**NOTE: Do not install this (these) oven(s) in any area with an ambient temperature in excess of 95° F / 35° C. Doing so will cause damage to the unit.**



**CAUTION:** Oven must be operated on approved basis only.

## VENTILATION

A VENT IS REQUIRED: Local codes prevail. These are the “authority having jurisdiction” as stated by the NATIONAL FIRE PROTECTION ASSOCIATION, INC. in NFPA 96 latest edition. In addition, to be in compliance with the NFPA 54 Section 10.3.5.2, this unit must be installed with a ventilation hood interlock that prevents the unit from operating when the ventilation hood is off. For further ventilation information, see below.

## VENTILATION GUIDELINES

A ventilation hood is required to remove heat and cooking odors. For gas ovens, a ventilation hood is also required to remove the products of combustion. The hood and HVAC installation must meet local codes to gain approval by the authority having jurisdiction. Requirements may vary throughout the country depending on the location by city, county, and state. Obtain information from the authority having jurisdiction to determine the requirements for your installation. Obtain information and review copies of codes or documents that will be used to inspect and approve your installation. Your ventilation hood supplier and HVAC contractor should be contacted to provide guidance. A properly engineered and installed ventilation hood and HVAC system will expedite approval and reduce oven maintenance costs. Proper ventilation is the oven owner’s responsibility.

The ventilation hood must operate in harmony with the building HVAC system. It typically requires between 1200 and 3500 CFM exhaust. (The “Efficiency” of various hood designs makes it necessary to specify such a wide range of ventilator CFM.) Make up air must be supplied by either a hood design or the HVAC system. This will vary with hoods from various manufacturers.

**CAUTION: Prevent airflow through the cooking tunnel. Air must NOT be directed onto the oven front or at side of cooking area or rear of oven.**

Performance will be evaluated during Start-up Checkout by conducting a smoke candle test. The hood must capture all smoke from the oven. This is required to assure proper performance of the oven and to eliminate additional service calls that occur when ambient temperatures are too high. In all cases, the ambient temperature around the oven must be less than 95° F / 35° C when the oven is operating. In certain localities, other chemical or gaseous methods of detecting adequate capture will be the requirement to meet the local code authority.

The drawing shown on page 8 is a typical installation and is intended to be a guideline. It is not a rigid specification. Hood dimensions and the positioning of the hood over the oven will vary with hood manufacturers.

NOTE: Lincoln can provide oven spec sheets that show the dimensions of the oven, KW or BTU ratings and other information that will be useful to both the ventilation hood supplier and the HVAC contractor.

*IN AUSTRALIA:* Refer to Standard AS 5601. This standard specifies the requirements for piping, flueing, ventilation and appliance installation associated with use of or intended use of fuel gases. The requirements of AS 5601 are to be used in conjunction with, but do not take precedence over, any statutory regulations that may apply in any area.

## LINCOLN IMPINGER® OVEN, MODEL SERIES 1000 – 1200 AND 1400 DOUBLE DECK OR SINGLE UNIT CANOPY VENTILATION RECOMMENDATIONS

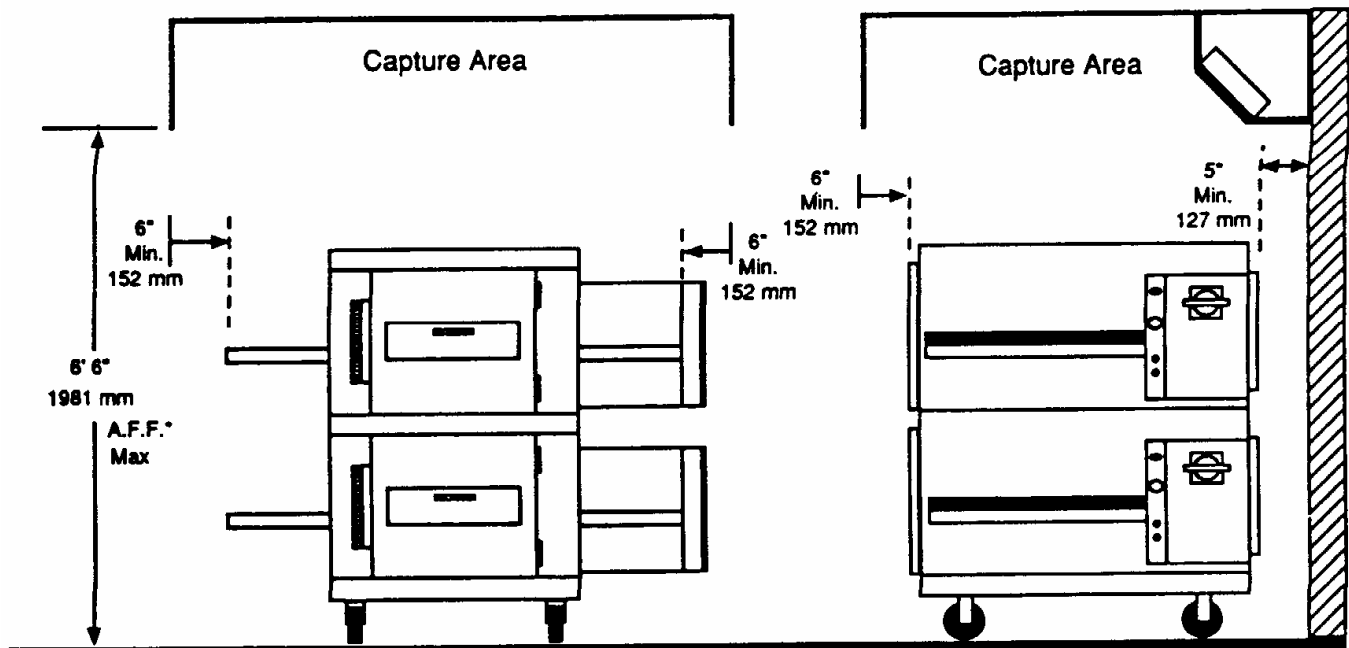

\* AFF = Above Finished Floor

### SMOKE CANDLE TEST – VENTILATION SYSTEM VERIFICATION

#### OVEN SET-UP FOR THIS TEST:

1. This test is to be done on the bottom oven of a multiple oven system, or a single oven.
2. The conveyor must be off.
3. The oven temperature must be set and operating at 550°F/288°C.

#### TEST PROCEDURE:

Note: Use Lincoln Smoke Candle #369361 (in Australia, an alternate method of coloring the air may be used).

1. Wear heat resistant gloves to prevent burns to your hands.
2. Put the smoke candle in a cake pan approximately 8 inches (200 mm) x 8 inches (200 mm) x 2 inches (50 mm) deep or equivalent.
3. Open the optional access window in the oven door, or insert candle through conveyor opening.
4. Light the fuse of the smoke candle and immediately put the pan and candle into the center of the oven cavity, on the conveyor belt. (Close the access window or door.)
5. Observe the smoke pattern coming out of the oven openings and the collection of this smoke by the ventilation system.
6. The ventilation system must capture all the smoke from the oven.

### GENERAL INFORMATION

The instructions that follow are intended as a guide for preparing for the installation of the Impinger® Conveyor Ovens, Series 1000 – 1200 and 1400.

First and foremost, each crate should be examined before signing the Bill of Lading to report any visible damage caused by the trucker in transit, and to account for the proper number of crates.



## UNLOADING

When the oven arrives it should consist of:

1. A crate containing oven body, conveyor, fingers, crumb pans, and pan stops. (Some models may have the conveyor packed separately.)
2. A package containing the stand and top.

It is recommended that you have a material-handling device available to unload.

**DO NOT LIFT EXCESSIVE WEIGHT!**

## IF THERE IS APPARENT DAMAGE:

UNITED STATES AND CANADA: Arrangements should be made to file a claim against the carrier, as Interstate Commerce Regulations require that the consignee initiate a claim.

ALL SHIPMENTS TO OTHER COUNTRIES: Freight terms will be developed and extended on an individual basis.

Proper and secure storage facilities should be arranged for the oven(s). If necessary, protect it from outdoor or damp conditions at all times before installation.

## UNCRATING

When you have all the crates unloaded, open the crates and remove the plastic covers. Inspect at once for concealed damage. If anything appears to be damaged, contact the appropriate persons immediately to file a damage claim. After completing this inspection, finish unpacking the oven and all other components. **Be sure to remove the cardboard from the plenum shroud.** Move all components inside near the area where they will be assembled in the order in which they will be assembled.

THE OVEN WILL CLEAR THROUGH A 30" (762 mm) DOORWAY BY USING THE FOLLOWING PROCEDURE:

1. Model 1000 and 1400 Series
  - A. Remove conveyor; see page 16 for instructions. (Some units may have conveyor packed separately.)
  - B. Remove thumb screws and baffle from the left side of the oven.
  - C. Place the left side on a four wheel moving dolly and it will clear a 30" (762 mm) doorway.
2. Model 1200 Series
  - A. Remove conveyor; see page 16 for instructions. (Some units may have conveyor packed separately.)
  - B. Place wood strips on a 4-wheel dolly.
  - C. Place oven on its back, on the 4-wheel dolly, placing the wood strips in proper place to avoid crushing wire way and BACK COVER. Unit will clear a 30" (762 mm) doorway.

## EXTERIOR DIMENSIONS

Gas and electrical services should be located as shown below. If flexible services are provided, they must meet code requirements for such installation.

## MANUAL GAS VALVE INSTALLATION

When installing the gas valve that is supplied with the oven, as shown in the drawing to the right, it is our suggestion that an elbow be placed on the oven pipe first. This will allow the flexible hose to be attached in a downward direction eliminating possible stress to the hose.

### SPECIFICATIONS

Body: Stainless Steel  
Power: Gas and/or Electric  
DB Level:  $\leq 71$ dba  
Operating Temperature Range: 300° - 600° F  
(149° - 316° C)

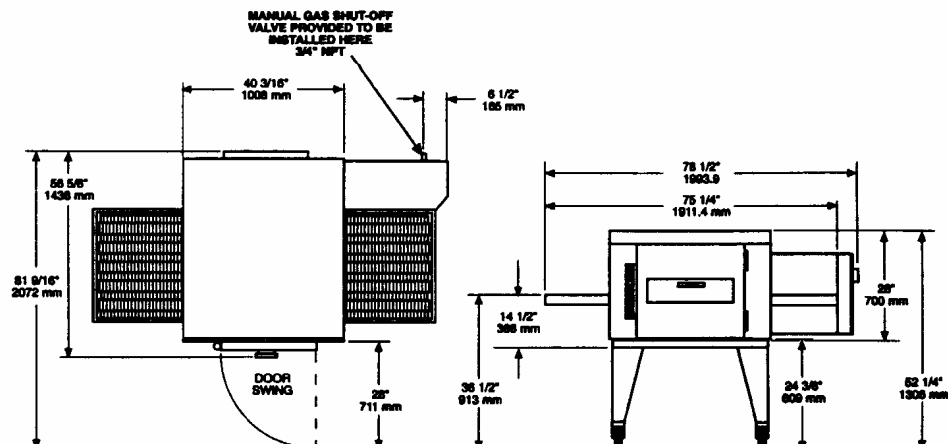



## **WARNING INT'L (CE):**

This appliance must be properly grounded at time of installation. Failure to ensure that this equipment is properly grounded can result in electrocution, dismemberment or fatal injury.

## **CODE REFERENCE**

### **GAS CODE REFERENCE**

Safe and satisfactory operation of this oven depends to a great extent upon its proper installation, and it should be installed, as applicable in accordance with the National Fuel Gas Codes, ANSI Z223.1/NFPA 54, latest version, Manufacturers' installation Instructions and local municipal building codes.

1. The oven and its individual shut off valve must be disconnected from the gas supply piping system during any pressure testing of that system at test pressures in excess of ½ psig (3.45kPa).
2. The oven must be isolated from the gas supply piping system by closing its individual manual shut off valve during any pressure testing of the gas supply system at test pressures equal to or less than ½ psig (3.45kPa).

IN MASSACHUSETTS: The minimum length of a flexible gas supply hose is thirty-six (36") inches.

IN CANADA: The installation of these appliances is to be in accordance with CSA B.149.1 latest version – Natural Gas and Propane Installation Code – and/or local codes.

IN AUSTRALIA: To be installed in accordance with AS 5601-2004 and 4563-2004 Gas Installation Code.

### **ELECTRICAL CODE REFERENCE**

When installed, this appliance must be electrically grounded and its installation must comply with the National Electric Code, ANSI-NFPA 70, latest edition, the Manufacturers' Installation Instructions, and applicable local municipal building codes.

IN CANADA: All electrical connections are to be made in accordance with CSA C22.2 latest version – Canadian Electrical Code and/or local codes.

ALL OTHER COUNTRIES: Local gas and/or electrical codes will prevail.

1. Strain Relief is provided with each oven. International Dealer/Distributors provide applicable power cord/plug for each customer.
2. All pole disconnection switch 3mm open contact distance.
3. To prevent electrical shock, an equal potential bonding ground lug is provided in the back. This allows the oven to be connected to an external bonding system.
4. If used as double or triple stack and each oven has its own disconnection switch, all switches should be close together.

### **RESTRAINT REQUIREMENT – GAS OVEN(S) ON CASTERS, U.S. AND AUSTRALIA**

1. The installation shall be made with a gas connector that complies with the Standard for Connectors for Movable Gas Appliances, ANSI Z21.69 latest version, and a quick disconnect device that complies with the Standard for Quick Disconnect Devices for Use With Gas Fuel, ANSI Z21.41 latest version.

IN CANADA: The installation shall be made with gas connectors that comply with Canadian Code CSA 6.16 latest version and quick disconnects complying to Canadian Code CSA 6.9 latest version.

IN AUSTRALIA: To be installed in accordance with AS 5601-2004 and 4563-2004 Gas Installation Code.

2. The installation of the restraint must limit the movement of the oven(s) without depending on the connector, the quick disconnect device or its associated piping to limit the oven movement.
3. If the restraint must be disconnected during maintenance or cleaning, it must be reconnected after the oven has been returned to its originally installed position.

## **OPERATIONS**

1. Screw lifting eye "B" of cable assembly to hole "A".
2. Screw eye bolt "C" of cable assembly to stud in wall "D" or floor anchor "E".

**NOTE: Installation point is the same for single and double stack oven(s).**

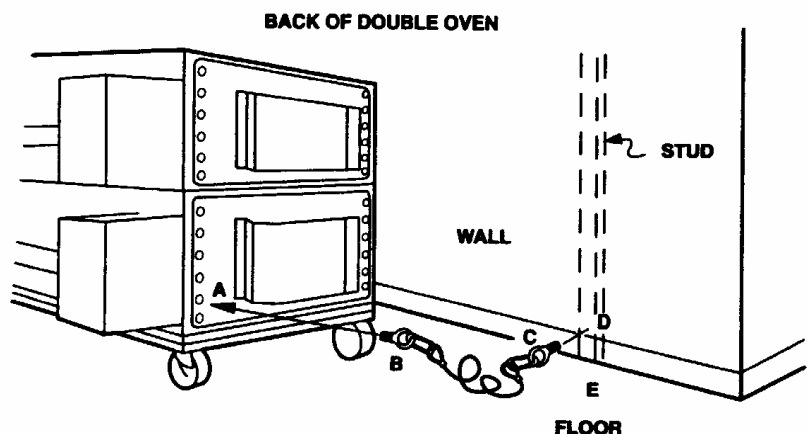

## STAND AND FINGER ASSEMBLY

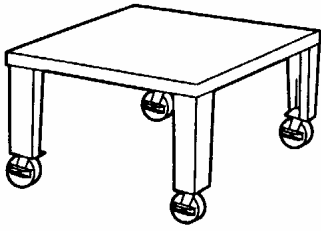

1. The stand is a 40" (1016 mm) x 49" (1245 mm) rectangle. Set it in place with a 40" side facing out. This will be the front of the oven. Using a carpenter's level, level all four (4) sides of the stand. To raise or lower the stand use the leg adjusters. Ovens on casters require a level floor. NOTE: The oven top is packed with oven stand. Remove top from stand before assembly.

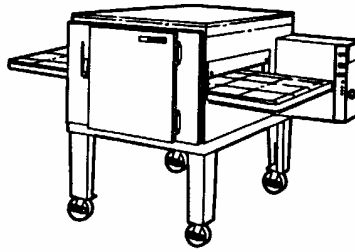

2. Remove the oven from the dolly and set it on the stand. The control panel should be on the right rear as you face the oven. Be sure that the oven sets squarely on the stand and is fully seated. For a single oven, install top. For double, see step 3.



3. If you purchased a double stack oven, place the second oven on top of the first one. Be sure that it sets on squarely and is fully seated. The control panel goes on the right rear. Now install oven top.

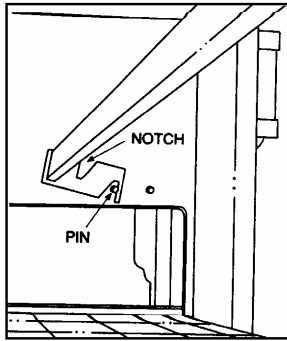

4. Before installing the retaining brackets in the oven(s), be sure all of the packing material is removed from the plenum shroud. Install the finger retaining brackets by placing them upside down and hooking the retaining pin as shown above.

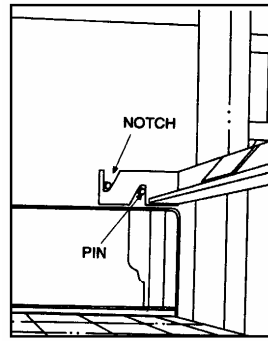

5. Rotate the finger brackets until the notches in the brackets sit on the retaining pins.

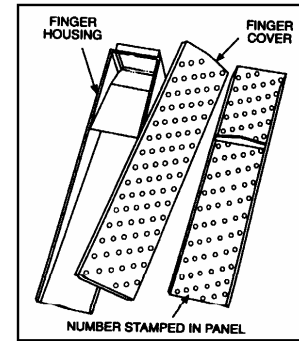

6. Assemble fingers as shown in steps 7 and 8.

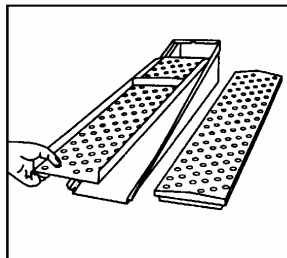

7. Insert columnating plate so the step goes under the lip of the finger housing and the plate lies flush with the housing side edge.

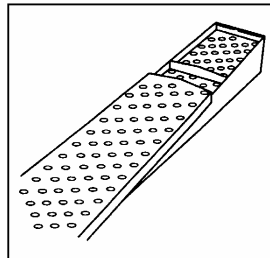

8. Install cover by sliding it on the small end.

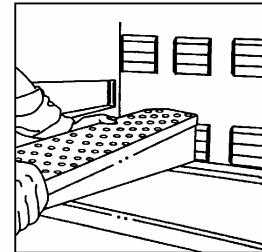

9. Insert assembled finger through door opening starting with lower left. NOTE: The customer MUST tell you what position to place the assembled finger in, for their application.

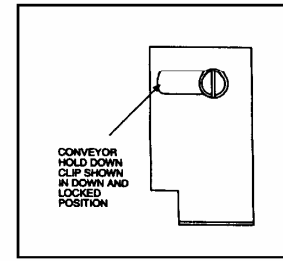
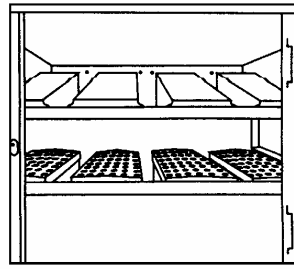
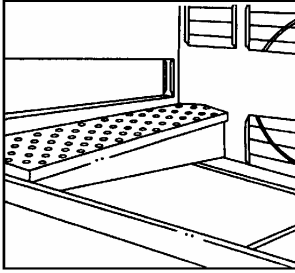

10. Install finger in the oven by sliding it over the plenum flange and setting the front bracket. **BE SURE THAT THE FINGER SETS SQUARELY OVER THE PLENUM FLANGES AND THE HOLES POINT IN THE PROPER DIRECTION.** Top fingers point down, bottom fingers point up.

11. Repeat step 10 until all eight (8) fingers are installed.

Install conveyor and crumb pans before operation. See page 17 for conveyor installation instructions.

NOTE: Prior to inserting into the oven opening, slide the conveyor hold-down clips so the screw head is in the left side slot, then rotate counter clockwise to the up position.

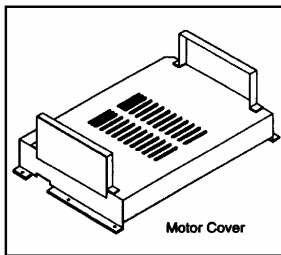

12. Attach Motor Cover as shown with bolts provided.

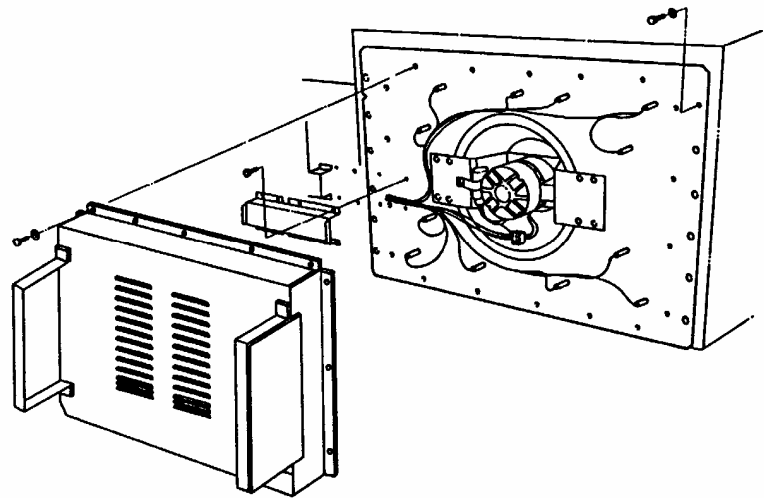

## IMPINGER® FINGER COLUMNATING PLATES

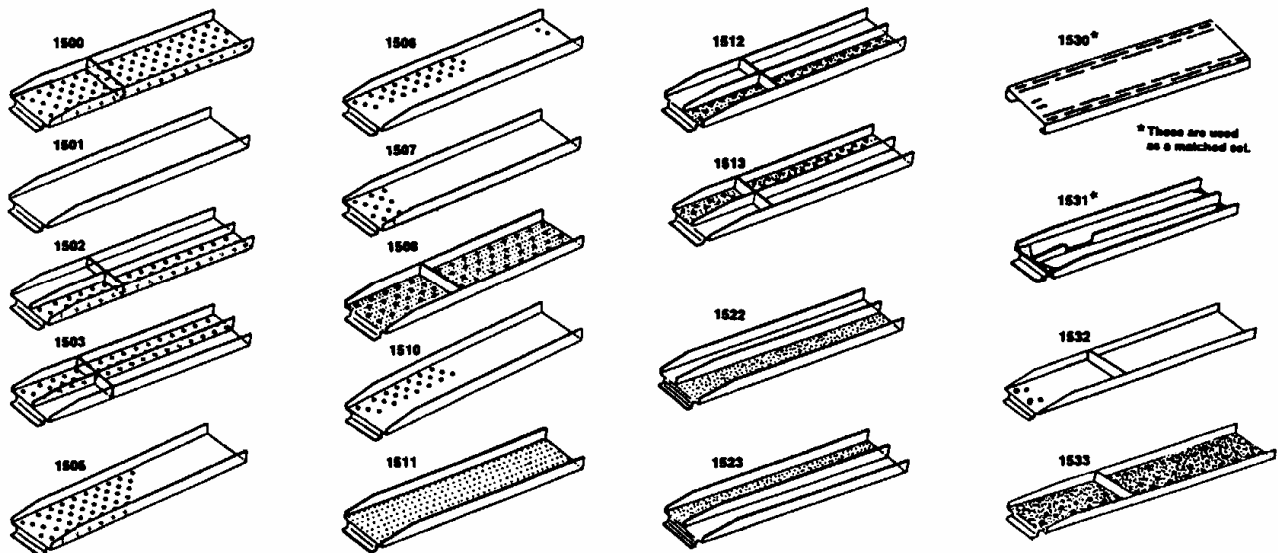

## FINGER HOUSING BAFFLE PLATE ADJUSTEMENTS

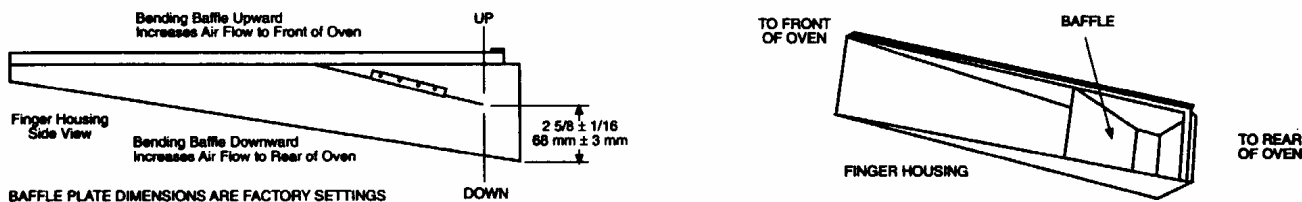

The finger housing has a baffle mounted inside to balance the air flow to the rear and front of the oven. If the product is cooking more or less in the rear of the oven than in the front, it is possible the finger housing baffle needs to be adjusted. If it is deemed necessary to adjust the air balancing baffle, be sure to adjust all eight (8) finger housing to exactly the same opening. Determine if more air (heat) is required at front or rear of oven then open or close off that air by bending the baffle in the proper direction. See drawing above.

## PROGRAMMING THE DIGITAL ADVANTAGE 1450 SERIES TOUCH PAD

### INTRODUCTION – START-UP AND SHUT DOWN

For the operator, the panel has a power up, run, and program menu modes. To start the oven, turn the power switch on. To shut down the oven, turn the power switch off.

### FRONT PANEL LAYOUT

The front panel contains four (4) momentary push-buttons: TEMP, TIME, UP & DOWN. There is a 2 line x 16 character VFD display.

### TEMPERATURE SETPOINTS

For Digital Advantage ovens, there is one setpoint. To enter the setpoint mode, press the TIME & TEMP buttons together and hold for 5 seconds. Pressing the UP or DOWN push-buttons will raise or lower the temperature to the desired setting. In the Fahrenheit, F mode, the temperature is adjusted in 5 degree increments. When in Centigrade, C mode, the temperature adjustment will be in 1 degree increments. Pressing and holding the UP or DOWN keys will allow the settings to “roll” at a much faster rate. When the desired temperature is indicated, release all keys. After 5 seconds, the selected setpoints will be stored and remain in memory.

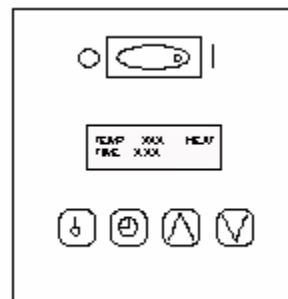

### TIME SETPOINTS

There is one setpoint for the conveyor speed. Enter the setpoint mode as mentioned above. The speed can be set as follows:

- 1:00 to 9:55 in 5 second increments
- 10:00 to 12:45 in 15 second increments
- 13:00 to 19:30 in 30 second increments
- 20:00 to 30:00 in 1 minute increments

### JUMPING BETWEEN MENUS

Pressing the TIME push-button while in the TEMP setting mode (and vice versa) will cause the menu selection to jump over to that mode.

### DIAGNOSTIC MESSAGES

The Digital Advantage ovens have diagnostic messages within the control. In the unexpected event that there is a failure in the oven operation, the following messages will appear in the control.

#### OPEN PROBE

This occurs when there is no temperature being sent to the controller from the baking chamber.

#### SHORTED PROBE

This occurs when a constant temperature signal (as opposed to the normal cyclical cavity temperature) is being sent to the controller from the baking chamber.

**CAUTION: This message can also occur when there is no gas supply to the oven. If the oven does not detect a temperature fluctuation in 5 minutes, the error message will appear. Be sure to check the gas valve and gas hose for proper connections.**

#### BELT JAM

This occurs when the conveyor motor fails.

## CONVEYOR

The conveyor for the Digital Advantage oven has a different drive cog than the Full Featured Impinger® oven. The drive cog on the conveyor for the Digital Advantage oven is a 15 tooth cog where the Full Featured Impinger® oven has a 10 tooth cog.

**CAUTION: On installations where a Digital Advantage Oven is stacked with a Full Featured Impinger® oven, THE CONVEYORS CANNOT BE INTERCHANGED. INTERCHANGING CONVEYORS WILL AFFECT COOKING TIMES.**

The conveyor for the Digital Advantage oven will have a label to identify proper use.

**ADVANTAGE OVENS  
ONLY**

## REVERSING SWITCH

The Digital Advantage ovens have a belt direction-reversing switch located on the back of the control box.

## IMPINGER® MODEL SERIES 1000 AND 1200

### START-UP

1. Push switches for FAN, CONVEYOR, and HEAT to "ON." The electric oven should come on immediately. The gas oven should light in 45-50 seconds.
2. **GAS OVEN ONLY!** If the indicator lamp does not light, turn HEAT switch off, wait 5 minutes and turn HEAT switch on again.
3. Turn oven dial to desired temperature.
4. Preheat oven for 30 minutes.
5. To set belt speed, slowly adjust oven time dial to reach desired time.
6. After preheat, adjust oven temperature and conveyor to final desired settings.

### SHUT DOWN

1. Push switches for FAN, CONVEYOR, and HEAT to "OFF."  
NOTE: Prior to serial #20657 the main fan will continue of run until the internal oven wall temperatures fall below 200° F / 93° C. Temperature indicator will show a lower figure than actual wall reading. Temperature display shuts off when oven fan is turned off.

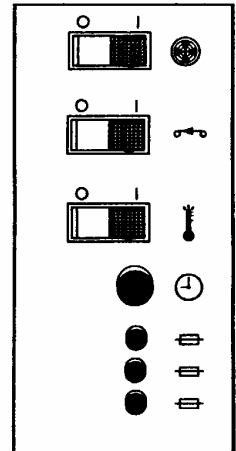

## ADVANTAGE MODEL SERIES 1400 WITH ANALOG CONTROLS

### START-UP

1. Turn switch on.
2. Turn thermostat to desired setting.  
NOTE: For gas ovens, the lamp should light in 45-50 second. If lamp does not light, turn switch off, wait 5 minutes and restart.
3. Preheat oven for 30 minutes.  
NOTE: The amber light above the temperature control dial should go on and off indicating heating system operation.
4. Adjust conveyor speed, time control, and readjust if necessary.

### SHUT DOWN

1. To shut down, turn off switch.

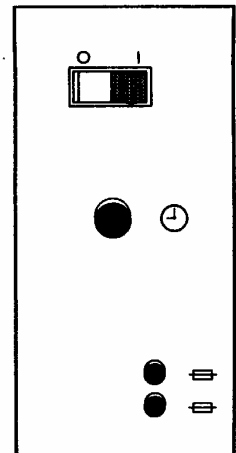

## PREVENTIVE MAINTENANCE

Although this oven has been designed to be as trouble-free as possible, periodic preventive maintenance is essential to maintain peak performance. It is necessary to keep the motors, fans, and electronic controls free of dirt, dust and debris to insure proper cooling. Overheating is detrimental to the life of all components mentioned. The periodic intervals for preventive cleaning may vary greatly depending on the environment in which the oven is operating. You must discuss the need for preventive maintenance with your Authorized Service Agency to establish a proper program. If there are any questions that the service agency cannot answer, please contact Lincoln Foodservice Technical Service Department at (800) 678-9511.

## INFORMATION ON USE OF OVEN

As explained in “Concepts,” the Impinger® oven functions by directing high velocity streams of heated air directly on the food products. Because air is the heat source, it is effective even on sensitive foods. Compared to conventional ovens and even convection ovens, the cooking time of products in the Impinger® Conveyor ovens can be as much as two (2) to four (4) times faster. Several factors may affect the cooking time of any special product such as: 1) oven temperature setting, 2) conveyor speed, 3) position of columnating plate in oven, and 4) adjustments of the 2 baffles on the conveyor openings.

We encourage you to experiment with the oven by trying different temperature settings and belt speeds. Also, try to control the cooking of the product by re-arranging the optional columnating plates.



### **CAUTION:**

**DO NOT WORK AROUND CONVEYOR BELT WITH LONG HAIR, LOOSE CLOTHING, OR DANGLING JEWELRY. GETTING CAUGHT IN THE BELT COULD RESULT IN DISMEMBERMENT OR FATAL INJURY.**

## OPERATOR MAINTENANCE



### **WARNING - DANGER:**

**DISCONNECT POWER SUPPLY BEFORE SERVICING OR CLEANING THIS OVEN. SAFEGUARD POWER SO IT CAN NOT BE ACCIDENTALLY RESTORED. FAILURE TO DO SO COULD RESULT IN DISMEMBERMENT, ELECTROCUTION, OR FATAL INJURY. THERE IS MORE THAN ONE POWER SUPPLY CONNECTION POINT WHEN OVENS ARE STACKED, SO MAKE SURE THAT ALL SWITCHES ARE IN OFF POSITION BEFORE CLEANING OR MAINTENANCE.**

To maintain maximum efficiency of the oven, it is necessary to keep it clean, all ventilation louvers on the oven must be cleaned regularly. Oven use and type of product will actually determine the frequency of cleaning. The conveyor drive chain should be checked during the weekly cleaning cycle to see if it has become loose. Loose chain operation will DAMAGE the conveyor drive motor.

If the oven fails to operate, check the circuit breaker to be sure it is turned on. Also, check the fuses on the control panel to be sure that they are good before you call the Authorized Service Agency. The name and phone number of the Authorized Service Agency should be located at the bottom of the data plate.

## CLEANING INSTRUCTIONS



### **CAUTION:**

**OVEN MUST BE COOL. DO NOT USE POWER CLEANING EQUIPMENT, STEEL WOOL, OR WIRE BRUSHES ON STAINLESS STEEL SURFACES.**

### **DAILY**

1. Clean exterior surfaces of the oven by wiping it down with a mild detergent and clean water, or a commercial stainless cleaner.
2. Clean crumb pans and guards by washing with a mild detergent solution and rinsing with clean water.
3. Clean the interior by sweeping up all loose particles, then wash with a mild detergent solution and rinse with clean water.
4. Clean the conveyor belt by wiping with a clean cloth or brushing with a soft wire brush. Lincoln catalog #369217.

**NOTE: DO NOT USE A CAUSTIC OR ALKALINE BASE CLEANER ON INTERIOR OF THE OVEN. THIS WILL RUIN THE ALUMINIZED FINISH OF THE OVEN INTERIOR.**

On exterior of oven, deposits of baked-on splatter, oil, grease, or light discoloration may be removed with any of several commercial cleaners. Consult with your local supplier.



### **CAUTION:**

**WHEN USING CLEANING SOLUTIONS, BE SURE THEY MEET LOCAL AND NATIONAL HEALTH STANDARDS.**

### **WEEKLY**

1. Remove fingers, disassemble and clean. Instructions on page 16.
2. Remove conveyor, disassemble and clean. Instructions on page 16.

**NOTE:** Be sure to clean and inspect the ventilation hood in accordance with the ventilation hood manufacturer's specifications.

## FINGER REMOVAL AND DISASSEMBLY FOR CLEANING

1. Open door and remove upper fingers. Note any particular placement of fingers that you may have, such as fully closed, half-closed, or fully open, columnating plates.
2. Remove conveyor and then remove bottom fingers.
3. For finger disassembly, see page 11, figures 6, 7, and 8.
4. Reassemble fingers in reverse order with the step of the columnating plate facing downward so it fits under the lip of the finger housing.
5. Re-install finger in oven. Be sure that they are fully seated over the plenum flanges and the holes are pointing toward the conveyor.

## CONVEYOR DISASSEMBLY FOR CLEANING

### TO REMOVE CONVEYOR FROM OVEN

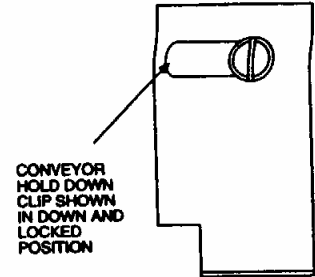
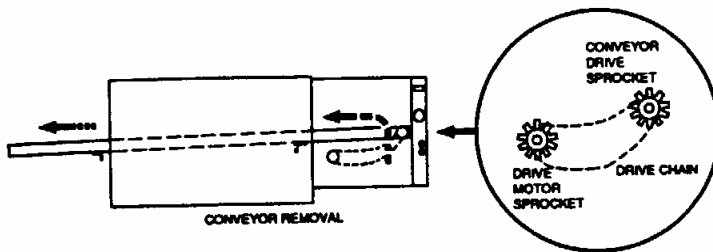

1. Remove conveyor chain guard. Remove crumb pans.
2. Next, slide the conveyor hold-down clips so the screw is in the left side of the slot, then rotate counterclockwise to the up position.
3. Lift right end of conveyor and push in approximately 3" (76 mm). Remove drive chain.
4. Pull conveyor out the right end. Place on table or work surface.

NOTE: For the Model 1200 Series, steps 3 and 4 are performed on the left end of conveyor.

### TO REMOVE CONVEYOR BELT

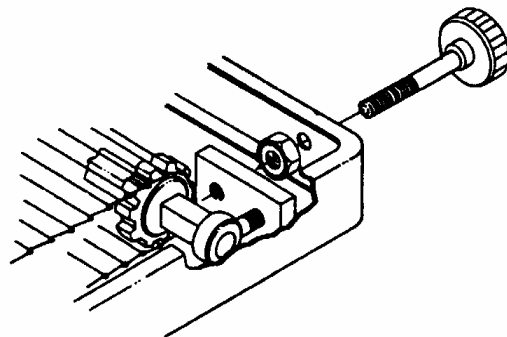
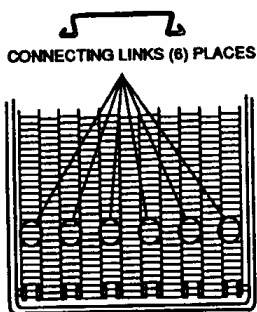

5. Locate connecting links on the conveyor belt, turn belt to place the links on the top left end of the conveyor, approximately 8" (203 mm) from the shaft.
6. On Model Series 1000 ONLY, loosen jam nut and unscrew the tension adjustment screws. Push the idler shaft in against the conveyor support bars.
7. You can easily remove the connecting links by grasping them with a pair of pliers and slipping the eye of the connecting link over the wire of the other links. *Also notice the direction of the opening on the links.* – The belts will have to be reinstalled with the opening facing the same way. Carefully pull out the belt, rolling it up as you go. After removal, it may be placed in a pan of detergent solution to soak. Rinse with clean water.

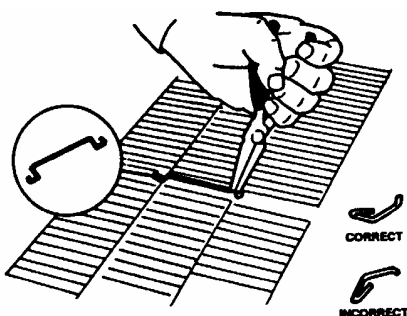



## CONVEYOR REASSEMBLY CONVEYOR BELT INSTALLATION

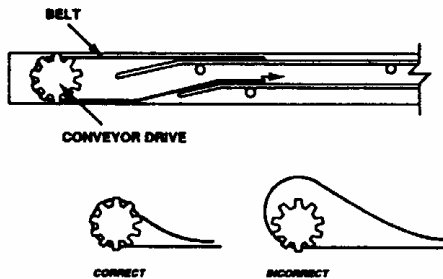

1. Put conveyor belt back on by setting the rolled belt to the left of the conveyor and thread approximately 2/3 of the belt over the bottom slider bed.

Put the loose end of the belt around the idler shaft and back on the conveyor. The belt must lay on top of the upper conveyor slider bed.

NOTE: The belt should curl around the conveyor sprockets and lay flat on top of the sprockets. If the belting does not curl around the sprockets and lay flat, remove the belting and turn the belting over. Reinstall.

Pull all of the slack belt through the conveyor until both ends are on top of the conveyor on the left end.

### TO INSTALL CONVEYOR IN OVEN

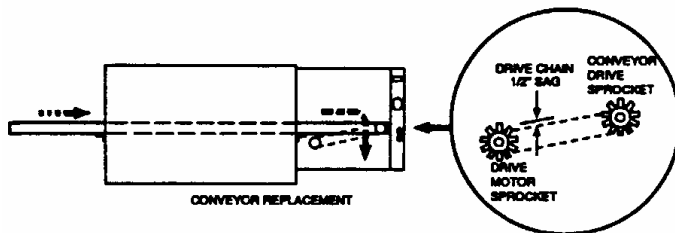

5. Insert the conveyor through the opening in the right side. Sprocket should be to the right side of the conveyor. NOTE: For Model Series 1200, step 1 is performed on the left end of the conveyor.
6. Slide conveyor through the oven chamber until the locking bar on driving end of the conveyor is approximately 2" – 3" (50 – 76 mm) into the oven chamber. Install drive chain by placing it over the driving sprocket and placing it over the conveyor sprocket.



## CAUTION:

SET TENSION ON THE CONVEYOR BELT. THE BELT SHOULD BE ABLE TO BE LIFTED ENOUGH TO ALLOW IT TO BE 1/4" (6 MM) FROM THE TOP OF THE CONVEYOR OPENING ON THE OVEN. DO NOT OVER TIGHTEN BELT!

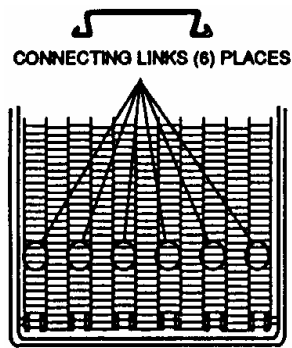

2. Replace belt and reconnect splice clips as shown in step 7 on page 16.

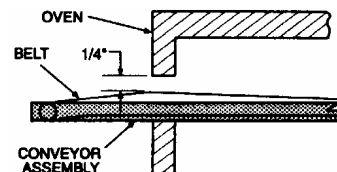

3. The conveyor has no adjustments (Series 1200 and 1400). If belt becomes too tight or loose, a link will have to be installed or removed. Proper tension allows the belt to be lifted within 1/4" from the top of the conveyor opening.

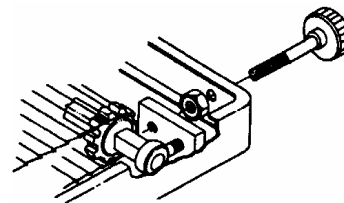

4. Model 1000 Series Only: Pull idler shaft toward the end of the conveyor and screw tension adjustment knobs back in. DO NOT OVER TIGHTEN BELT! Tighten the iam nuts against the adjustment plate.

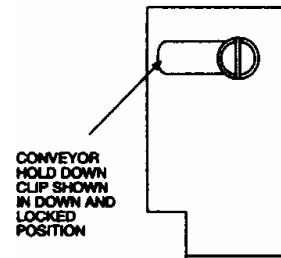

7. Lift conveyor just enough to allow you to pull the conveyor toward you until the locking bar is outside of the oven cavity, at the same time push the conveyor downward so that the bar locks on the outside of the oven wall. Next, slide the conveyor hold-down clips so the screw head is in the left side of the slot, rotate clip clockwise to down position and slide so the screw head is in right side of the slot to lock.
8. Reinstall conveyor crumb pans and chain guard cover.

## CONCEPTS

The Impinger® Conveyor Oven produced by Lincoln Foodservice Products, LLC utilizes a revolutionary cooking concept called “AIR IMPINGEMENT.” It provides exceptional baked food product quality in far less time than conventional devices on the market. The “AIR IMPINGEMENT” system directs a high velocity stream of heated air at the food product being baked. This blast effect penetrates the boundary layer of air encircling the product and heats the food more efficiently because the air concentrates heat on the product. Greater heat transfer rates, which result in products baking two to four times faster than conventional means, are possible with “AIR IMPINGEMENT.”

The “AIR IMPINGEMENT” process develops the high velocity air stream with a specially designed fan that draws super-heated air from a heat source (either gas or electric). This air is directed through a plenum chamber to patented “JET FINGERS” which have hundreds of focused jet ports that “impinge” the heated air onto the product surface. The heated air is recycled to the heat source after striking the product, thus reducing energy consumption.

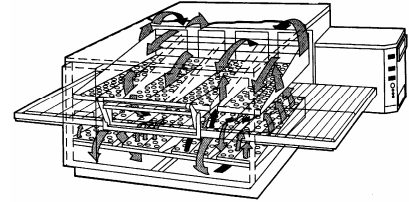

A variable speed conveyor system moves food products through the oven one after another to improve product flow during the cooking process.

The “AIR IMPINGEMENT” process is tolerant enough for sensitive food products and effects proper crisping and even browning of such products as they pass through the oven because air is the medium which heats the food product.

## STACKING THE 1000-1200-1400 SERIES WITH OTHER IMPINGER® OVENS

The Model 1100 Series Ovens (Impinger® II) may be mounted on top of the 1000-1200-1400 Series units. A special mounting kit (catalog #1126 and #1122) MUST BE USED.

The model 1400 Series units may be mounted on either a 1000 (Impinger® I) or a 1200 (Impinger® III) with the addition of a flue cap, part #1456, (Supplied with the oven) to the bottom unit. Since the 1400 Series units are flueless, they may be mounted below an Impinger® I or III without a flue extension. The 1400 Series units are not approved to be mounted with, on, or below any equipment except an indicated above.

**DO NOT ATTEMPT TO OPERATE THE OVEN** until connection of utility service and installation has been fully inspected (START-UP CHECKOUT) by an Authorized Service Technician or a Lincoln Foodservice Products, LLC Service Representative. This service is required by Lincoln Foodservice Products, LLC in order to insure the oven(s) is properly installed and in working order. The warranty becomes effective upon verification of proper installation.

The warranty shall not apply if the oven(s) are started up and operated prior to the “START-UP CHECKOUT” being performed by an Authorized Service Technician or a Lincoln Foodservice Products, LLC Service Representative.



**WARNING:** IF THE SUPPLY CORD APPEARS TO BE DAMAGED, DO NOT ATTEMPT TO OPERATE UNIT. CONTACT A SERVICE AGENT OR QUALIFIED ELECTRICIAN TO REPAIR.

## HOW TO OBTAIN SERVICE

If the oven fails to operate, check the circuit breaker to be sure it is turned on (on a gas oven check the manual gas valve to insure it is in the ON position) and check the fuses on the back of the oven to be sure they are good before you call the Authorized Service Agency. The name and phone number of the Authorized Service Agency should be located on the oven or contact the factory at (800) 678-9511 for the name of the nearest agency.

## FUNCTIONS

### THERMAL CUT-OUT SWITCH

The Impinger I unit includes a “safety thermal cut-out switch” for your protection. This safety related device is designed to insure that the Impinger I unit will not overheat and damage the unit. In the unlikely event that the Impinger I unit would exceed the specified operating temperature range, the “safety thermal cut-out switch” will activate, thus blocking power to the Impinger I unit and causing it to turn off.



**CAUTION:** IN ORDER TO AVOID A HAZARD DUE TO INADVERTENT RESETTING OF THE THERMAL CUTOUT, THIS APPLIANCE MUST NOT BE SUPPLIED THROUGH AN EXTERNAL SWITCHING DEVICE, SUCH AS A TIMER OR CONNECTED TO A CIRCUIT THAT IS REGULARLY SWITCHED ON AND OFF BY THE UTILITY.

# APPENDIX A – LABEL DEFINITIONS

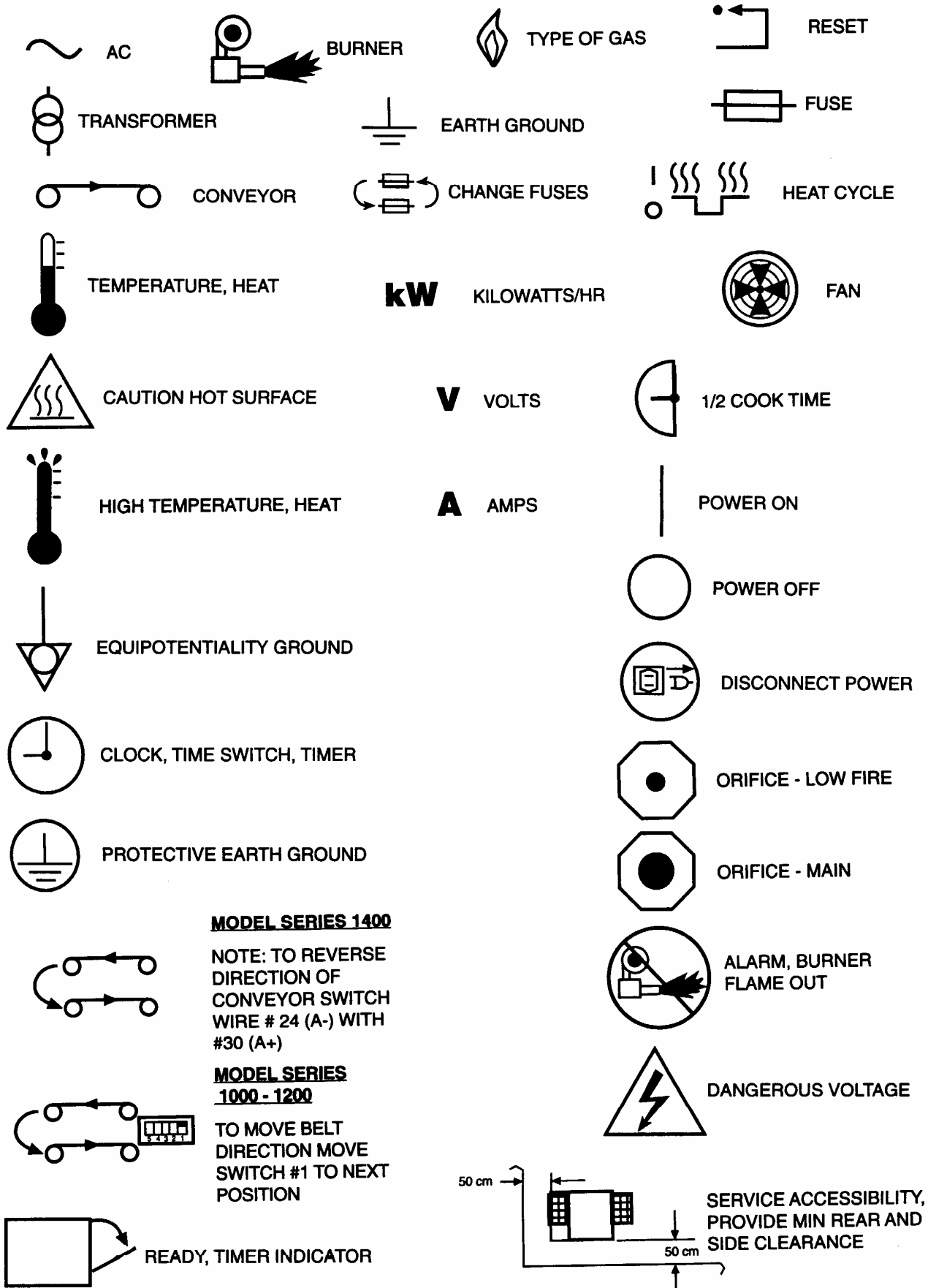

## LIMITED WARRANTY FOR COMMERCIAL PRODUCTS

### LIMITED WARRANTY

Lincoln Foodservice Products, LLC ("Lincoln") warrants this product to be free from defects in material and workmanship for a period of one (1) year from the date of purchase.

During the warranty period, Lincoln shall, at Lincoln's option, repair, or replace parts determined by Lincoln to be defective in material or workmanship, and with respect to services, shall re-perform any defective portion of said services. The foregoing shall be the sole obligation of Lincoln under this Limited Warranty with respect to the equipment, products, and services. With respect to equipment, materials, parts and accessories manufactured by others, Lincoln's sole obligation shall be to use reasonable efforts to obtain the full benefit of the manufacturer's warranties. Lincoln shall have no liability, whether in contract, tort, negligence, or otherwise, with respect to non-Lincoln manufactured products.

### WHO IS COVERED

This Limited Warranty is available only to the original purchaser of the product and is not transferable.

### EXCLUSIONS FROM COVERAGE

- Repair or replacement of parts required because of misuse, improper care or storage, negligence, alteration, accident, use of incompatible supplies or lack of specified maintenance shall be excluded
- Normal maintenance items, including but not limited to, light bulbs, fuses, gaskets, O-rings, interior and exterior finishes, lubrication, conveyor belt, motor bushes, broken glass, etc. adjustments and calibrations for temperatures, speed and air flows
- Failures caused by improper or erratic voltages
- Improper or unauthorized repair
- Changes in adjustment and calibration after ninety (90) days from equipment installation date
- This Limited Warranty will not apply to any parts subject to damage beyond the control of Lincoln, or to equipment which has been subject to alteration, misuse or improper installation, accidents, damage in shipment, fire, floods, power changes, other hazards or acts of God that are beyond the control of Lincoln
- This Limited Warranty does not apply, and shall not cover any products or equipment manufactured or sold by Lincoln when such products or commercial equipment is installed or used in a residential or non-commercial application. Installations not within the applicable building or fire codes render this Limited Warranty and any responsibility or obligations associated therein null and void. This includes any damage, costs, or legal actions resulting from the installation of any Lincoln commercial cooking equipment in a non-commercial application or installation, where the equipment is being used for applications other than those approved for by Lincoln.

### LIMITATIONS OF LIABILITY

The preceding paragraphs set forth the exclusive remedy for all claims based on failure of, or defect in, products or services sold hereunder, whether the failure or defect arises before or during the warranty period, and whether a claim, however instituted, is based on contract, indemnity, warranty, tort (including negligence), strict liability, implied by statute, common-law or otherwise, and Lincoln its servants and agents shall not be liable for any claims for personal injuries, incidental or consequential damages or loss, howsoever caused. Upon the expiration of the warranty period, all such liability shall terminate. THE FOREGOING WARRANTIES ARE EXCLUSIVE AND IN LIEU OF ALL OTHER WARRANTIES, WHETHER WRITTEN, ORAL, IMPLIED OR STATUTORY NO IMPLIED WARRANTY OF MERCHANTABILITY OR FITNESS FOR PARTICULAR PURPOSE SHALL APPLY. LINCOLN DOES NOT WARRANT ANY PRODUCTS OR SERVICES OF OTHERS.

### REMEDIES

The liability of Lincoln for breach of any warranty obligation hereunder is limited to: (i) the repair or replacement of the equipment on which the liability is based, or with respect to services, re-performance of the services; or (ii) at Lincoln's option, the refund of the amount paid for said equipment or services.

Any breach by Lincoln with respect to any item or unit of equipment or services shall be deemed a breach with respect to that item or unit or service only

### WARRANTY CLAIM PROCEDURE

Customer shall be responsible to:

- Immediately advise the Dealer or Lincoln's Authorized Service Agent of the equipment serial number and the nature of the problem.
- Verify the problem is a factory responsibility. Improper installation or misuse of equipment, are not covered under this Limited Warranty.
- Cooperate with the Service Agency so that warranty service may be completed during normal working hours.
- Travel Time not to exceed two hours and mileage not to exceed one hundred (100) miles.

### GOVERNING LAW

Limited Warranty shall be governed by the laws of the state of Delaware, USA, excluding their conflicts of law principles. The United Nations Convention on Contracts for the International Sale of Goods is hereby excluded in its entirety from application to this Limited Warranty

Lincoln Foodservice Products, LLC  
1111 North Hadley Road  
Fort Wayne, Indiana 46804  
USA  
www.lincolnfp.com

This page intentionally left blank.

This page intentionally left blank.

This page intentionally left blank.



Lincoln Foodservice Products, LLC  
1111 North Hadley Road  
Fort Wayne, Indiana 46804  
United States of America

Phone : (260) 459-8200  
U.S. Fax: (888) 790-8193  
Int'l Fax: (260) 436-0735

Technical Support Hotline: (800) 678-9511

[www.lincolnfp.com](http://www.lincolnfp.com)

