

Electric, self contained, tilting kettle with worm drive tilt mechanism and 375lt capacity, 2/3 jacketed. Solid state controls for accurate temperature control ( $\pm 1^{\circ}\text{C}$ ) and low water safety. All exterior surfaces are stainless steel.

**STANDARD FEATURES**

- Splash proof element cover with a double gasket seal
- Water resistant controls, splash-proof construction
- Large pouring lip for high capacity and chunky products
- 50 psi steam jacket rating for higher cooking temperatures
- Self-contained - needs only an electrical hook-up
- Steam jacket filled with treated water, venting and/or refilling is not required
- Re-inforced rolled rim design prevents damage to kettle rim, eliminates "bar rim designs"
- Welded-in heating elements, (holds vacuum better, won't leak or loose water)
- Contains "spare" element as contingency
- Easily cleaned: kettle and all exterior surfaces are of type 304 stainless steel with an #4 finish
- Solid state water level control (no sight glass gauge to break or leak)
- Tilt mechanism of roller bearings and case hardened self-locking worm and segment gear
- Tri-leg supports with level adjustable feet for floor bolting
- Accurate, consistent solid state temperature controls (mechanical thermostat not as accurate) - less than  $\pm 1^{\circ}\text{C}$  variance (ideal for simmering). Operating temperature range from  $63^{\circ}\text{C}$  -  $127^{\circ}\text{C}$
- Rear mounted easy access pressure gauge and pressure relief valve to prevent tampering.
- Heat Deflector Shield (HS001)

**OPTIONAL FEATURES**

- Pan Carrier (PCK)
- Flow Diverter (FD)
- Food Strainers (FS)
- Cooking Baskets and Tri-Basket Supports (BS and TBS)
- Kettle Accessory Kit (KAK) includes: Clean-up Brush (CB) - 914mm Kettle Paddle (KP), 914mm Kettle Whip (KW) - 914mm Kettle Brush, Draw-Off Brush (DB) - 24 oz. Ladle (KL)
- Lift-Off Covers (CL100)
- Measuring Strip (MS)
- Kettle Markings (KM)
- Swing Funnels for drain (SW)
- Spring-assisted, hinged, rotatable, domed Stainless Steel Cover (CHS)
- 51mm diameter Tangent Draw-Off Valve (TD2) or 76mm (TD3)
- Hot and Cold Water Faucet with Swing Spout and Mounting Bracket (DPK)
- Type 316 Stainless Steel Kettle Liner (316)

**TECHNICAL DATA**

Power Supply: 3NAC 415V 50Hz, 25.1 amp  
(Cable & Plug not included)

Total Output: 18.1kW

Capacities (per kettle):  
(in 230 gram servings, other sizes may be calculated)  
100 gallons / 375 litres - 1600 servings

**SHIPPING DATA**

Shipping Weight: 235 kg

Shipping Dimensions: 1370W x 1370D x 1370H mm

SPECIFICATIONS ARE SUBJECT TO CHANGE WITHOUT NOTICE.

**CODING GUIDE FOR OPTIONS**

OPT	CHS and TD2
OPT1	316 Liner only
OPT2	CHS only
OPT3	CHS and TD3
OPT4	TD2 only
OPT6	CHS TD2 and 316
OPT8	CHS, TD3 and 316

\*add OPT suffix to product code.



**National Head Office**  
156 Swann Drive  
Derrimut VIC 3026  
Tel: +61 3 8369 4600  
Fax: +61 3 8369 4699  
[www.comcater.com.au](http://www.comcater.com.au)

**Melbourne**  
96-100 Tope Street  
South Melbourne VIC 3205  
Tel: +61 3 8699 1200  
Fax: +61 3 8699 1299

**Sydney**  
20/4 Avenue of the Americas  
Newington, NSW 2127  
Tel: +61 2 8775 9500  
Fax: +61 2 9648 4762

**Brisbane**  
1/62 Borthwick Avenue  
Murarrie QLD 4172  
Tel: +61 7 3900 2700  
Fax: +61 7 3399 5311

**Perth**  
Unit 16, 7 Abrams Street  
Balcatta, WA 6021  
Tel: +61 8 6217 0700  
Fax: +61 8 6217 0799



KEL100T - OPT2 shown

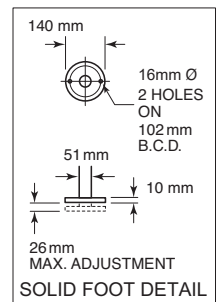
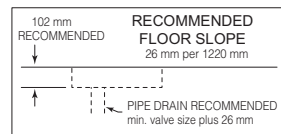
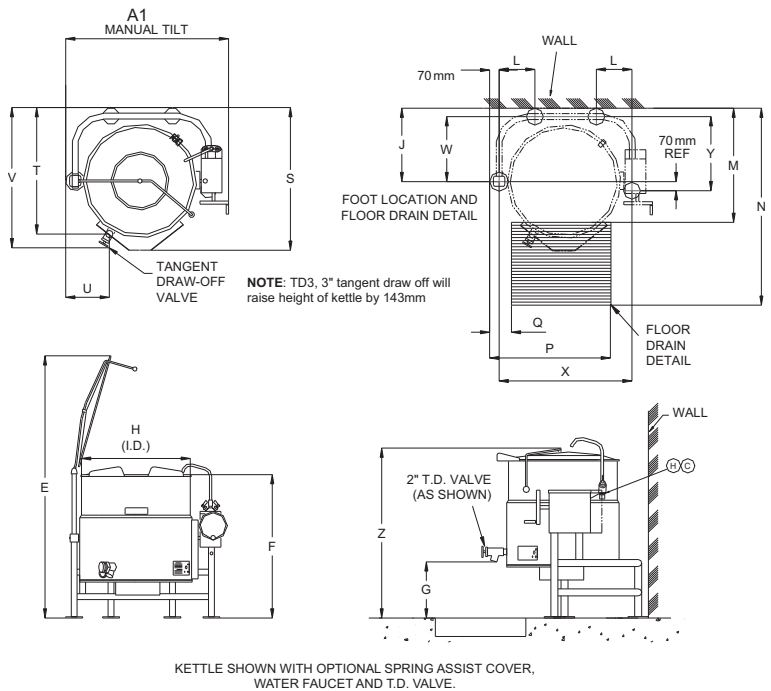

CLEARANCE	
RIGHT	= 4.0" handle clearance
LEFT	= .00"
REAR	= .00"

WATER $\text{H}_2\text{O}$	
$\frac{3}{8}$ " O.D. copper tube or $\frac{1}{2}$ " N.P.T. pipe.	
When ordered with optional faucet.	

**DIMENSIONS**

LITRES	A1	A2	E	F	G	H	J	L	M	N	P	Q	S	T	U	V	W	X	Y	
375	mm	1296	1439	2283	1237	413	902	651	296	915	1810	1029	103	1258	1194	235	1016	585	1099	651