



# Operators Manual

## Installation, Operation & Service

### Electric Table Top Kettles

#### MODELS:

##### Single Kettles

- KET-3-T
- KET-6-T
- KET-12-T
- KET-20-T\*

##### Twin Kettles

- TKET-3-T
- TKET-6-T
- TKET-12-T

\* Floor Type Leg Mount

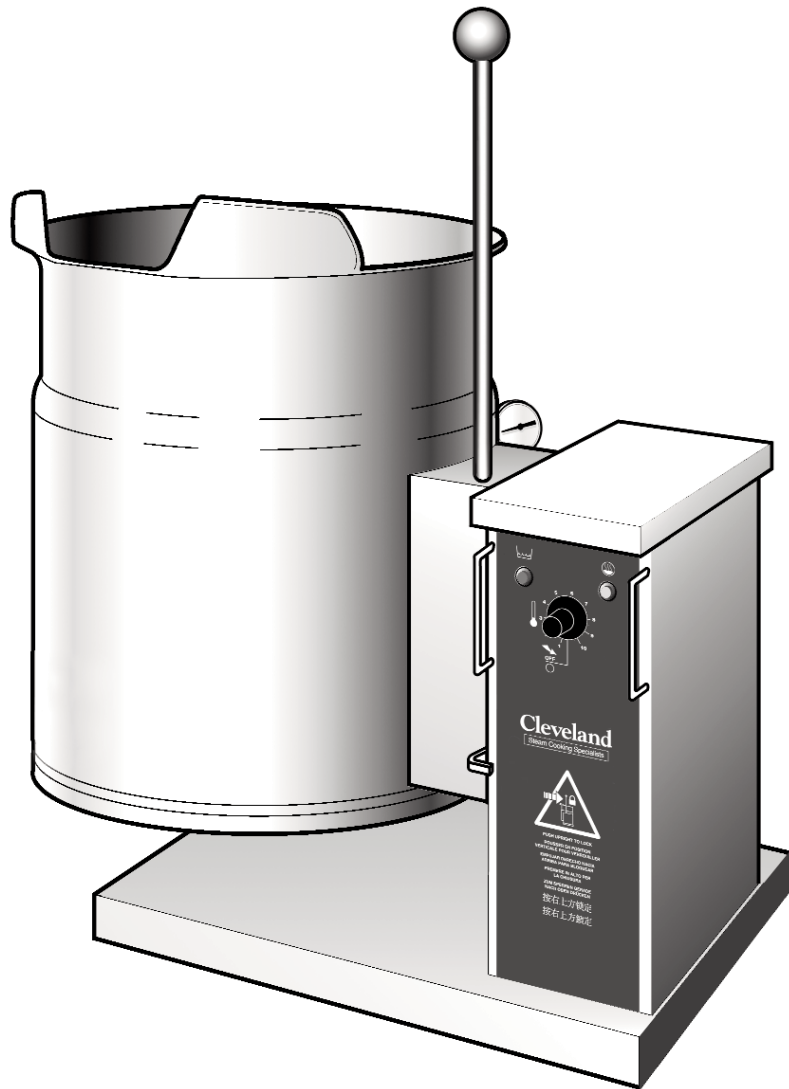

1333 East 179th St., Cleveland, Ohio, U.S.A. 44110

Enodis

Phone: (216) 481-4900 Fax: (216) 481-3782  
Visit our web site at [www.clevelandrange.com](http://www.clevelandrange.com)

# For your safety

## DANGER

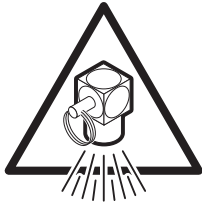

Keep clear of pressure relief discharge.



Keep hands away from moving parts and pinch points.

## IMPORTANT



Inspect unit daily for proper operation.

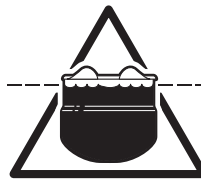

Do not fill kettle above recommended level marked on outside of kettle.

## CAUTION



Surfaces may be extremely hot! Use protective equipment.



Wear protective equipment when discharging hot product.



Do not lean on or place objects on kettle lip.

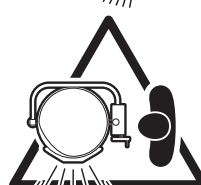

Stand clear of product discharge path when discharging hot product.

## SERVICING

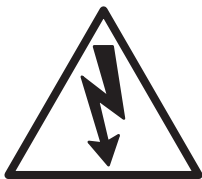

Shut off power at main fuse disconnect prior to servicing.



Ensure kettle is at room temperature and pressure gauge is showing zero or less prior to removing any fittings.

## GAS APPLIANCES

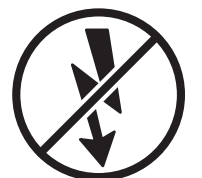

Do not attempt to operate this appliance during a power failure.



Keep appliance and area free and clear of combustibles.

# INSTALLATION

## GENERAL

Installation of the kettle must be accomplished by qualified electrical installation personnel working to all applicable local and national codes. Improper installation of product could cause injury or damage.

This equipment is built to comply with applicable standards for manufacturers. Included among those approval agencies are: UL, NSF, ASME/Ntl. Bd., CSA, CGA, ETL, and others. Many local codes exist, and it is the responsibility of the owner/installer to comply with these codes.

**Note:** Maximum voltage for LVD (low volt directive for Europe) to be 440 volts for CE marked appliances.

## INSPECTION

Before unpacking visually inspect the unit for evidence of damage during shipping.

If damage is noticed, do not unpack the unit, follow Shipping Damage Instructions shown below.

## SHIPPING DAMAGE INSTRUCTIONS

If shipping damage to the unit is discovered or suspected, observe the following guidelines in preparing a shipping damage claim.

1. Write down a description of the damage or the reason for suspecting damage as soon as it is discovered. This will help in filling out the claim forms later.
2. As soon as damage is discovered or suspected, notify the carrier that delivered the shipment.
3. Arrange for the carrier's representative to examine the damage.
4. Fill out all carrier claims forms and have the examining carrier sign and date each form.

## INSTALLATION

The first installation step is to refer to the Specification Sheets or Specification Drawings for detailed clearance requirements of the kettle. Next, carefully cut open the shipping carton for easy removal of the kettle.

### CLEARANCE REQUIREMENTS

Model #	Back*	Left Side	Right Side
<b>KET-3-T</b>	2 1/4"	0	0
<b>KET-6-T</b>	2 3/4"	0	0
<b>KET-12-T</b>	5 1/2"	0	0
<b>KET-20-T</b>	8"	0	0
<b>TKET-3-T</b>	6 5/8"	0	0
<b>TKET-6-T</b>	7 1/8"	0	0
<b>TKET-12-T</b>	9 7/8"	0	0

\* From back of mounting base.

### POUR PATH

Kettle Size	Min.	Max.
<b>3 Gallon</b>	15 1/2"	32"
<b>6 Gallon</b>	17 1/4"	36"
<b>12 Gallon</b>	18"	38"
<b>20 Gallon</b>	22"	45"

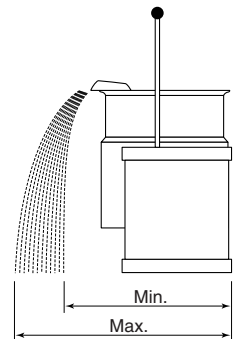

# ASSEMBLY

## Table-Top Models (3, 6 & 12 gallon)

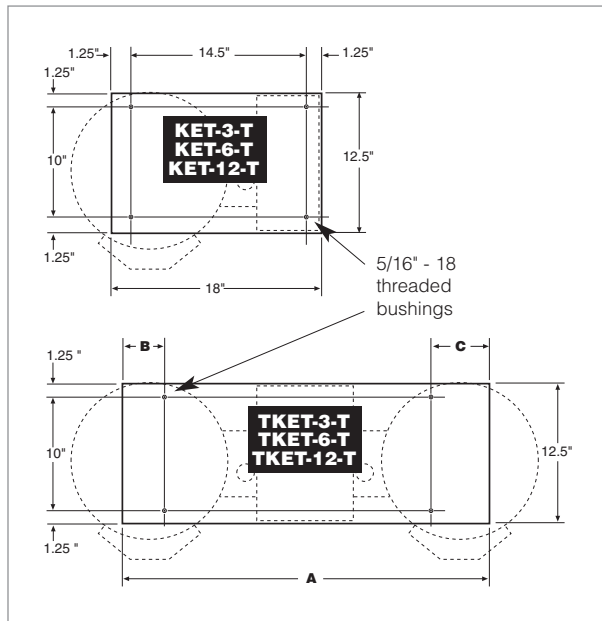

Model #	A	B	C
<b>TKET-3-T</b>	18"	2.25"	1.25"
<b>TKET-6-T</b>	24"	4.63"	4.63"
<b>TKET-12-T</b>	30"	7.75"	7.75"

Base Mounting Diagram

Table-top models (3, 6 & 12 gallon - single and twin) must be positioned on a firm, level stand, or existing counter top, and bolted in place. These models are supplied with four threaded mounting bushings welded to the underside of the base. An optional support stand with level adjustable legs is available. Once the kettle is secure, screw tilt handle into the threaded hole provided at the right side of kettle.

## Floor Type Leg Mount Models (20 gallon)

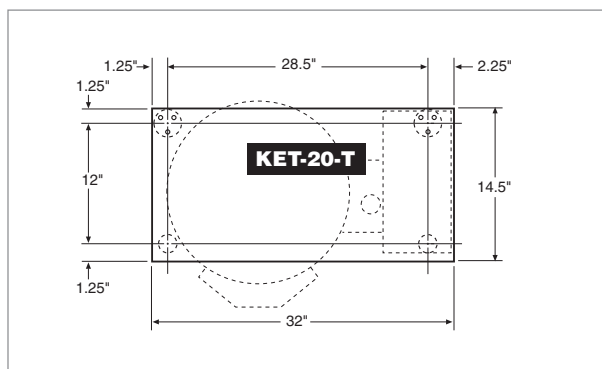

Base Mounting Diagram

Position on a firm, level surface, and bolt two flange feet in place. Once the kettle is secure, screw tilt handle into the threaded hole provided at the right of kettle.

## ELECTRICAL

**ENSURE THE ELECTRICAL SUPPLY MATCHES THE KETTLE'S REQUIREMENTS AS STATED ON THE RATING LABEL.**

This kettle is built to comply with applicable standards of manufacturers. Included among these approval agencies are UL, NSF, ASME/Ntl. Bd., CSA, ETL, and others. Many local codes exist, and it is the responsibility of the owner and installer to comply with these codes.

The electrical supply must match the power requirements specified on the kettle's rating plate. The copper wiring must be adequate to carry the required current at the rated voltage.

**Note:** Maximum voltage for LVD (low volt directive for Europe) to be 440 volts for CE marked appliances.

## WIRE CONNECTION

If unit does not have cord and plug option, remove the four screws securing the console cover and remove the cover. A wiring diagram is affixed to the underside of the cover. Feed permanent copper wiring through the cut-out in the rear or bottom of the console, and fasten to the three connection terminal block, which is mounted on the top of the console's control panel. Be sure to connect the ground wire to the separate ground terminal connector (ground lug). Replace console cover and secure it with the four screws.

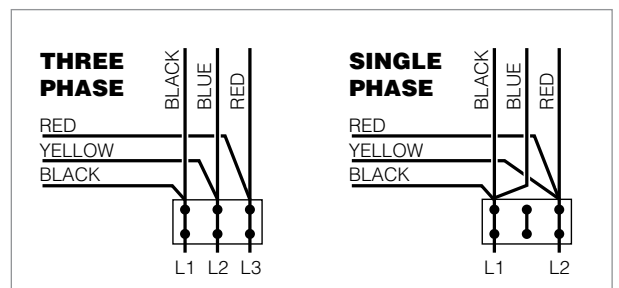

The kettle is wired for 3-phase operation at the factory. For single phase operation, rewire the terminal block to that shown in the above diagram.

## WATER

The sealed jacket of the electric kettle is precharged with the correct amount of a water based formula, and therefore, no water connection is required to the kettle jacket. The kettle can be equipped with optional hot and/or cold water faucet, requiring 1/2" copper tubing as supply lines.

## INSTALLATION CHECKS

Although the kettle has been thoroughly tested before leaving the factory, the installer is responsible for ensuring the proper operation of kettle once installed.

### Visual Checks

1. Check Marine Lock. See Marine Lock Testing Procedure.
2. Check Tilting:
  - A/** Handle is in place and firmly tightened.
  - B/** Kettle tilts smoothly and freely.
3. Insure there are:
  - A/** Four screws securely holding the console cover.
  - B/** The bottom cover is in place and held with a nut.

### Performance Checks

1. Supply power to the kettle by placing the fused disconnect switch to the "ON" position.
2. Before turning the kettle on, read the

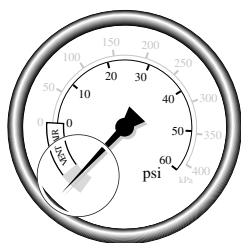

Vacuum/Pressure Gauge (**2**). The gauge's needle should be in the green zone. If the needle is in the "VENT AIR" zone, follow Kettle Venting Instructions.

3. Turn the kettle's ON/OFF Switch/Solid State Temperature Control (**5**) to "1" (Min.). The Heat Indicator Light (Green) (**6**) should remain lit, indicating the element is on, until the set temperature is reached (130°F/54°C). Then the green light will cycle on and off, indicating the element is cycling on and off to maintain temperature.
4. Tilt the kettle forward. After a few seconds the Low Water Indicator Light (Red) (**4**) should be lit when the kettle is in a tilted position. This light indicates that the element has automatically been shut off by the kettle's safety circuit. This is a normal condition when the kettle is in a tilted position.
5. Raise the kettle to the upright position. The Low Water Indicator Light (Red) (**4**) should go out when the kettle is upright.
6. Turn the ON/OFF Switch/Solid State Temperature Control (**5**) to "10" (Max.) and allow the kettle to preheat. The green light should remain on until the set temperature (260°F/127°C) is reached. Then the green light will cycle ON and OFF, indicating the element is cycling ON and OFF to maintain temperature. Fill the kettle with cold water to the steam jacket's welded seam. Refer to the Temperature Range Chart for the time required to bring the water to a boil.
7. When all testing is complete, empty the kettle and turn the ON/OFF Switch/Solid State Temperature Control (**5**) to the "OFF" position.

## CLEANING

After installation the kettle must be thoroughly cleaned and sanitized prior to cooking. See Cleaning Instructions.

## MARINE LOCK



Your unit is equipped with a marine lock to prevent accidental tilting. The following procedure should be used to tilt the kettle.

1. Grasp the tilt handle.

2. Hold the latch down to unlock tilting mechanism.
3. Pull the handle to tilt kettle.
4. To lock, return the kettle to its upright position and push handle back.

**NOTE: Inspect lock daily to ensure it is free moving and does not bind or stick. Clean lock if necessary (see Cleaning Instructions for details).**

# OPERATING INSTRUCTIONS

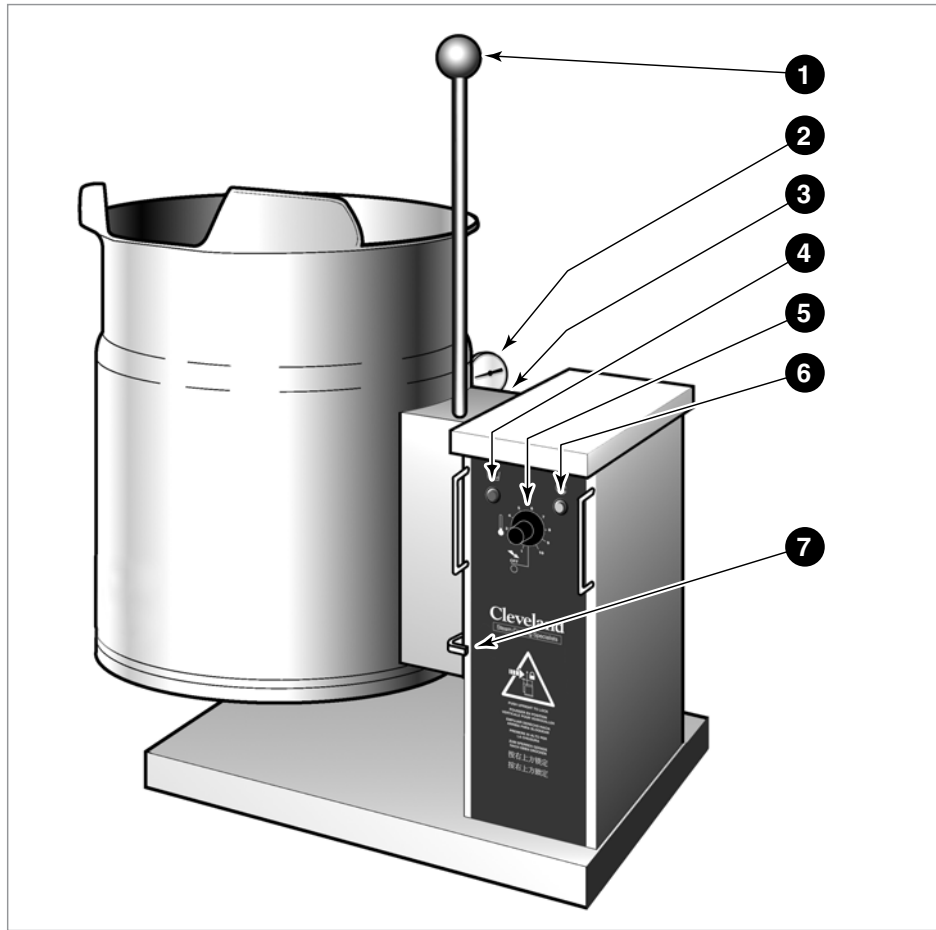

General Parts Drawing

ITEM #	DESCRIPTION	FUNCTION
1.	Tilting Handle	Used for tilting the kettle.
2.	Vacuum/Pressure Gauge	Indicate steam pressure in PSI inside steam jacket as well as vacuum in inches of mercury.
3.	Pressure Relief Valve (not shown)	This valve is used to vent the kettle and in the unlikely event there is an excess steam build-up in the jacket, this valve opens automatically to relieve this pressure.
4.	Low Water Indicator Light (Red)	When lit, it indicates that the kettle is low on water and will not operate in this condition. This will also light when the kettle is tilted.
5.	On-Off Switch/ Solid State Temperature Control	Turns kettle ON/OFF and allows the operator to adjust the kettle temperature in increments from 1 (Min.) to 10 (Max.). (see Temperature Range Chart).
6.	Heat Indicator Light (Green)	When lit, indicates that the kettle's element is on. Cycles ON-OFF with element.
7.	Marine Lock	Prevents unit from accidental tilting.

## OPERATING THE KETTLE

**DO NOT LEAN ON OR PLACE OBJECTS ON KETTLE LIP. SERIOUS INJURY COULD RESULT IF KETTLE TIPPED OVER, SPILLING HOT CONTENTS.**

1. Before turning kettle on, read the Vacuum/Pressure Gauge (2). The gauges needle should be in the green zone. Once heated, the kettle's normal maximum operating pressure is approximately 10-12 psi, while cooking a water base product.
2. Ensure that the electrical service to the kettle is turned on at the fused disconnect switch.

Temperature Control Setting	Approximate Product Temperature	
	°F	°C
<b>1.</b> (Min.)	130	54
<b>2.</b>	145	63
<b>3.</b>	160	71
<b>4.</b>	170	77
<b>5.</b>	185	85
<b>6.</b>	195	91
<b>7.</b>	210	99
<b>8.</b>	230	110
<b>9.</b>	245	118
<b>10.</b> (Max.)	260	127
<b>NOTE:</b> Certain combinations of ingredients will result in temperature variations		

Temperature Range Chart

3. Preheat the kettle by turning the ON/OFF Switch/Solid State Temperature Control (5) to the desired temperature setting (see above "Temperature Range Chart"). The Heat Indicator Light (Green) (6) will remain lit, indicating the element is on, until the temperature setting is reached. When the green light goes off, the elements are off, and preheating is complete.

**NOTE:** When cooking egg and milk products, the kettle should not be preheated, as products of this nature adhere to hot cooking surfaces. These types of food should be placed in the kettle before heating is begun.

4. Place food product into the kettle. The Heat Indicator Light (Green) (6) will cycle on and off indicating the elements are cycling on and off to maintain the set temperature.



**NOTE:** Do not fill kettle above recommended level marked on outside of kettle.

**NOTE:** The Low Water Indicator Light (Red) (4) should not be lit when kettle is in upright position during operation. This light indicates that the elements have been automatically shut off by the kettle's safety circuit. It is, however, normal for the red light to come on when the kettle is in a tilted position.

5. When cooking is completed turn ON/OFF Switch/Solid State Temperature Control (5) to the "OFF" position.
6. Pour the contents of the kettle into an appropriate container by tilting the kettle forward. Care should be taken to pour slowly enough to avoid splashing off the product.

**NOTE:** As with cleaning food soil from any cookware, an important part of kettle cleaning is to prevent food from drying on. For this reason, cleaning should be completed immediately after cooked foods are removed.

## APPROXIMATE BOILING TIMES

The accompanying chart shows approximate times required for electric kettles of various capacities to boil water. The ON/OFF Switch/Solid State Temperature Control must be set at "10" (Max.) throughout the heat-up period. Water will boil about 1/3 faster if the kettle is filled only to the outer steam jacket's welded seam resulting in a kettle filled to 2/3 capacity.

Kettle Capacity	Minutes
3 gallon/11 litre	15
6 gallon/23 litre	20
12 gallon/45 litre	25
20 gallon/80 litre	40

Approximate Boiling Times







# CLEANING INSTRUCTIONS



## CARE AND CLEANING

Cooking equipment must be cleaned regularly to maintain its fast, efficient cooking performance and to ensure its continued safe, reliable operation. The best time to clean is shortly after each use (allow unit to cool to a safe temperature).

## WARNINGS

- ⇒  Do not use detergents or cleansers that are chloride based or contain quaternary salt.  
**Chloride Cleaners**
- ⇒  Do not use a metal bristle brush or scraper.  
**Wire Brush &**
- ⇒  Steel wool should never be used for cleaning the stainless steel.  
**Steel Pads**
- ⇒  Unit should never be cleaned with a high pressure spray hose.  
**High Pressure Spray Hose**
- ⇒  Do not leave water sitting in unit when not in use.  
**Stagnant Water**

## CLEANING INSTRUCTIONS

1. Turn unit off.
2. Remove drain screen (if applicable). Thoroughly wash and rinse the screen either in a sink or a dishwasher.
3. Prepare a warm water and mild detergent solution in the unit.
4. Remove food soil using a nylon brush.
5. Loosen food which is stuck by allowing it to soak at a low temperature setting.
6. Drain unit.
7. Rinse interior thoroughly.
8. If the unit is equipped with a **Tangent Draw-Off Valve**, clean as follows:
  - a) Disassemble the draw-off valve first by turning the valve knob counter-clockwise, then turning the large hex nut counter-clockwise until the valve stem is free of the valve body.
  - b) In a sink, wash and rinse the inside of the valve body using a nylon brush.
  - c) Use a nylon brush to clean tangent draw-off tube.
  - d) Rinse with fresh water.
  - e) Reassemble the draw-off valve by reversing the procedure for disassembly. The valve's hex nut should be hand tight only.
9. If the unit is equipped with a **Butterfly Valve**, clean as follows:
  - a) Place valve in open position.
  - b) Wash using a warm water and mild detergent solution.
  - c) Remove food deposits using a nylon brush.
  - d) Rinse with fresh water.
  - e) Leave valve open when unit is not in use.
10. Using mild soapy water and a damp sponge, wash the exterior, rinse, and dry.

## NOTES

- ⇒ For more difficult cleaning applications one of the following can be used: alcohol, baking soda, vinegar, or a solution of ammonia in water.
- ⇒ Leave the cover off when the kettle is not in use.
- ⇒ For more detailed instructions refer to the Nafem Stainless Steel Equipment Care and Cleaning manual (supplied with unit).



# STAINLESS STEEL EQUIPMENT CARE AND CLEANING

(Supplied courtesy of Nafem. For more information visit their web site at [www.nafem.org](http://www.nafem.org))

## Contrary to popular belief, stainless steels ARE susceptible to rusting.

Corrosion on metals is everywhere. It is recognized quickly on iron and steel as slightly yellow/orange rust. Such metals are called "active" because they actively corrode in a natural environment when their atoms combine with oxygen to form rust.

Stainless steels are passive metals because they contain other metals, like chromium, nickel and manganese that stabilize the atoms. 400 series stainless steels are called ferritic, contain chromium, and are magnetic; 300 series stainless steels are called austenitic, contain chromium and nickel; and 200 series stainless, also austenitic, contains manganese, nitrogen and carbon. Austenitic types of stainless are not magnetic, and generally provide greater resistance to corrosion than ferritic types.

With 12-30 percent chromium, an invisible passive film covers the steel's surface acting as a shield against corrosion. As long as the film is intact and not broken or contaminated, the metal is passive and stain-less. If the passive film of stainless steel has been broken, equipment starts to corrode. At its end, it rusts.

## Enemies of Stainless Steel

There are three basic things which can break down stainless steel's passivity layer and allow corrosion to occur.

1. Mechanical abrasion
2. Deposits and water
3. Chlorides

**Mechanical abrasion** means those things that will scratch a steel surface. Steel pads, wire brushes and scrapers are prime examples.

**Water** comes out of the faucet in varying degrees of hardness. Depending on what part of the country you live in, you may have hard or soft water. Hard water may leave spots, and when heated leave deposits behind that if left to sit, will break down the passive layer and rust stainless steel. Other deposits from food preparation and service must be properly removed.

**Chlorides** are found nearly everywhere. They are in water, food and table salt. One of the worst chloride perpetrators can come from household and industrial cleaners.

## So what does all this mean? Don't Despair!

Here are a few steps that can help prevent stainless steel rust.

### 1. Use the proper tools.

When cleaning stainless steel products, use non-abrasive tools. Soft cloths and plastic scouring pads will not harm steel's passive layer. Stainless steel pads also can be used but the scrubbing motion must be in the direction of the manufacturers' polishing marks.

### 2. Clean with the polish lines.

Some stainless steel comes with visible polishing lines or "grain." When visible lines are present, always scrub in a motion parallel to the lines. When the grain cannot be seen, play it safe and use a soft cloth or plastic scouring pad.

### 3. Use alkaline, alkaline chlorinated or non-chloride containing cleaners.

While many traditional cleaners are loaded with chlorides, the industry is providing an ever-increasing choice of non-chloride cleaners. If you are not sure of chloride content in the cleaner used, contact your cleaner supplier. If your present cleaner contains chlorides, ask your supplier if they have an alternative. Avoid cleaners containing quaternary salts; it also can attack stainless steel and cause pitting and rusting.

### 4. Treat your water.

Though this is not always practical, softening hard water can do much to reduce deposits. There are certain filters that can be installed to remove distasteful and corrosive elements. To insure proper water treatment, call a treatment specialist.

### 5. Keep your food equipment clean.

Use alkaline, alkaline chlorinated or non-chloride cleaners at recommended strength. Clean frequently to avoid build-up of hard, stubborn stains. If you boil water in stainless steel equipment, remember the single most likely cause of damage is chlorides in the water. Heating cleaners that contain chlorides have a similar effect.

### 6. Rinse, rinse, rinse.

If chlorinated cleaners are used, rinse and wipe equipment and supplies dry immediately. The sooner you wipe off standing water, especially when it contains cleaning agents, the better. After wiping equipment down, allow it to air dry; oxygen helps maintain the stainless steel's passivity film.

### 7. Never use hydrochloric acid (muriatic acid) on stainless steel.

### 8. Regularly restore/passivate stainless steel.

## Recommended cleaners for specific situations

Job	Cleaning Agent	Comments
Routine cleaning	Soap, ammonia, detergent, Medallion	Apply with cloth or sponge
Fingerprints & smears	Arcal 20, Lac-O-Nu Ecoshine	Provides barrier film
Stubborn stains & discoloration	Cameo, Talc, Zud, First Impression	Rub in direction of polish lines
Grease & fatty acids, blood, burnt-on-foods	Easy-off, De-Grease It Oven Aid	Excellent removal on all finishes
Grease & oil	Any good commercial detergent	Apply with sponge or cloth
Restoration/Passivation	Benefit, Super Sheen	

## Review

1. Stainless steels rust when passivity (film-shield) breaks down as a result of scrapes, scratches, deposits and chlorides.
2. Stainless steel rust starts with pits and cracks.
3. Use the proper tools. Do not use steel pads, wire brushes or scrapers to clean stainless steel.
4. Use non-chlorinated cleaners at recommended concentrations. Use only chloride-free cleaners.
5. Soften your water. Use filters and softeners whenever possible.
6. Wipe off cleaning agent(s) and standing water as soon as possible. Prolonged contact causes eventual problems.

To learn more about chloride-stress corrosion and how to prevent it, contact the equipment manufacturer or cleaning materials supplier.

Developed by Packer Engineering, Naperville, Ill., an independent testing laboratory.

## MARINE LOCK

Use a small nylon bristle brush to remove food and debris from pivot point. If lock is still sticking have maintenance disassemble and clean pieces individually and reassemble.

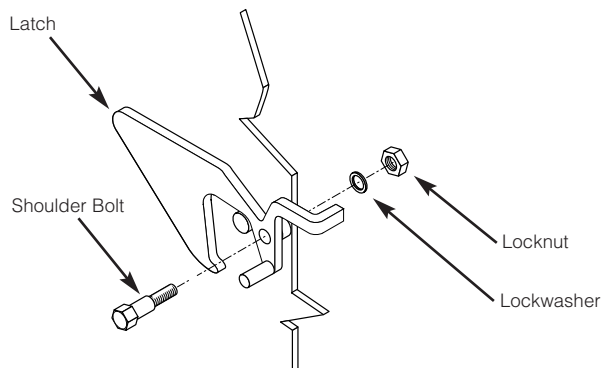

### Disassembly

1. Disconnect power from kettle.
2. Remove console cover from top of kettle's console.
3. Remove locknut and lockwasher from inside console.
4. Remove shoulder bolt from latch.
5. Clean all parts.

### Re-Assembly

6. Apply locktight to shoulderbolt where illustrated. Replace shoulder bolt and latch and tighten firmly.
7. Replace lockwasher and locknut inside the console and tighten firmly.
8. Test Marine Lock. See Marine Lock Testing Procedure.
9. Replace console cover.



## MARINE LOCK TESTING PROCEDURE

1. Check that lock clears stop pin on side box without rubbing when kettle is tilted (Figure A).
2. Check side to side play. Lock should remain fully over stop pin when pushed to it's maximum side to side play (Figure B).
3. Check that the kettle when pushed fully upright moves the lock to a closed position. To check this:
  - A/** Hold the latch firmly in the unlocked position while tilting the kettle back to an upright position.
  - B/** The kettle sidebox will force the lock into a new position.
  - C/** Hold the lock in this position and try to tilt the kettle forward. The latch should prevent the kettle from tilting.

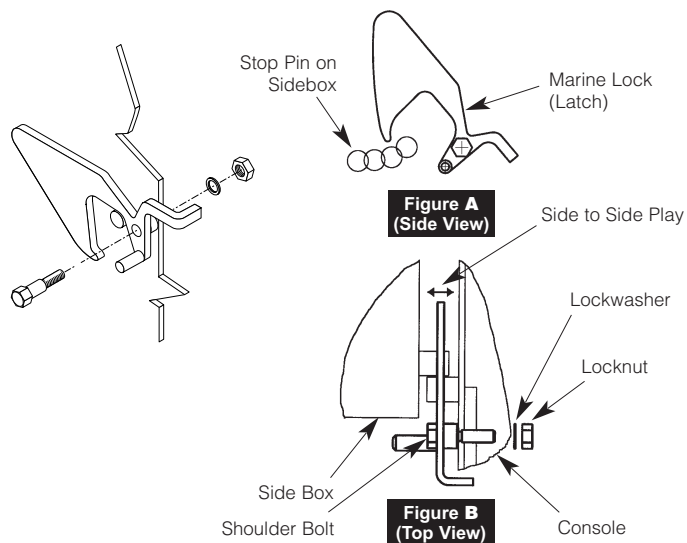

4. Check shoulder bolt is firmly seated against console body.
5. Check on inside of console box that shoulder bolt locknut is secure.

# SERVICE PARTS

## WARRANTY

Our Company supports a worldwide network of Maintenance and Repair Centers. Contact your nearest Maintenance and Repair Centre for replacement parts, service, or information regarding the proper maintenance and repair of your cooking equipment

In order to preserve the various agency safety certification (UL, NSF, ASME/Ntl. Bd., etc.), only factory-supplied replacement parts should be used. The use of other than factory supplied replacement parts will void warranty.

## FAUCET ASSEMBLY

ITEM NO.	PART NO.	DESCRIPTION	QTY.
1.	KE50825-2	3/4" Spout (KET-3/6/12/20-T) . . . . .	1
	KE50825-9	3/4" Spout (TKET-3/6/12-T) . . . . .	1
2.	FA95022	Retaining Ring . . . . .	1
3.	FA05002-19	"O" Ring . . . . .	1
4.	KE51736	Long Faucet Nut . . . . .	1
5.	SE50020	Hot Water Stem Assembly . . . . . (Double Pantry only)	1
6.	SE50021	Cold Water Stem Assembly . . . . .	1
7.	KE51401	Single Pantry Body . . . . . (c/w Item No. 6)	1
8.	KE50335	Adapter Washer . . . . . (Single Pantry only)	1
9.	KE51403	Double Pantry Body . . . . . (c/w Item No. 5&6)	1
10.	KE54159	Faucet Mounting Bracket . . . . .	1
11.	FA11258	Hex Cap Screw . . . . .	2
12.	FA30505	Washer . . . . .	2
13.	FA21008	Hex Nut . . . . .	2
14.	SE50447	Washer Horseshoe . . . . .	1

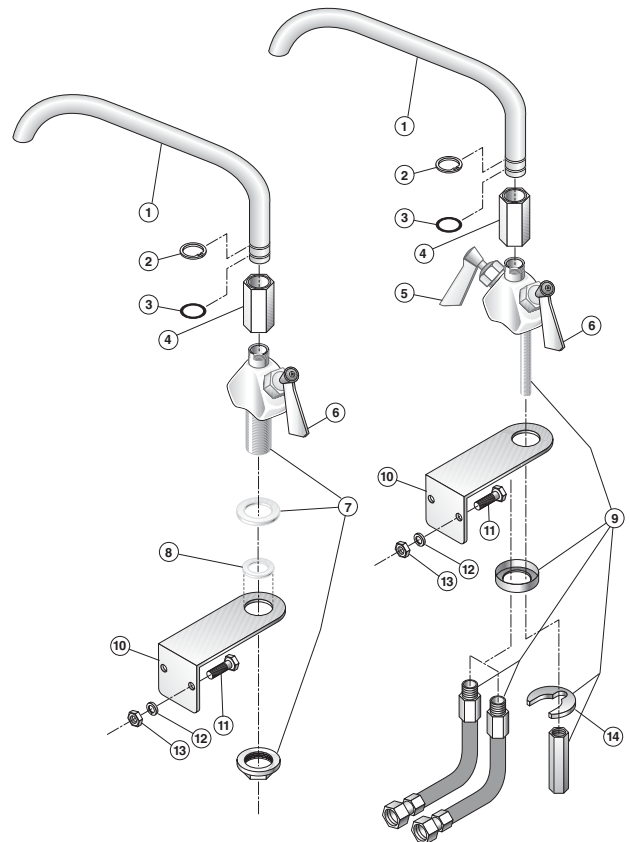

# KETTLE BOTTOM & SIDE

Bottom Cover  
 KE50572 6 gallon  
 KE50573 12 gallon  
 KE52041 3 gallon

KET00027 is the Cracker Barrel 6 Gallon Pot  
 KET00031 is the Cracker Barrel 12 Gallon Pot

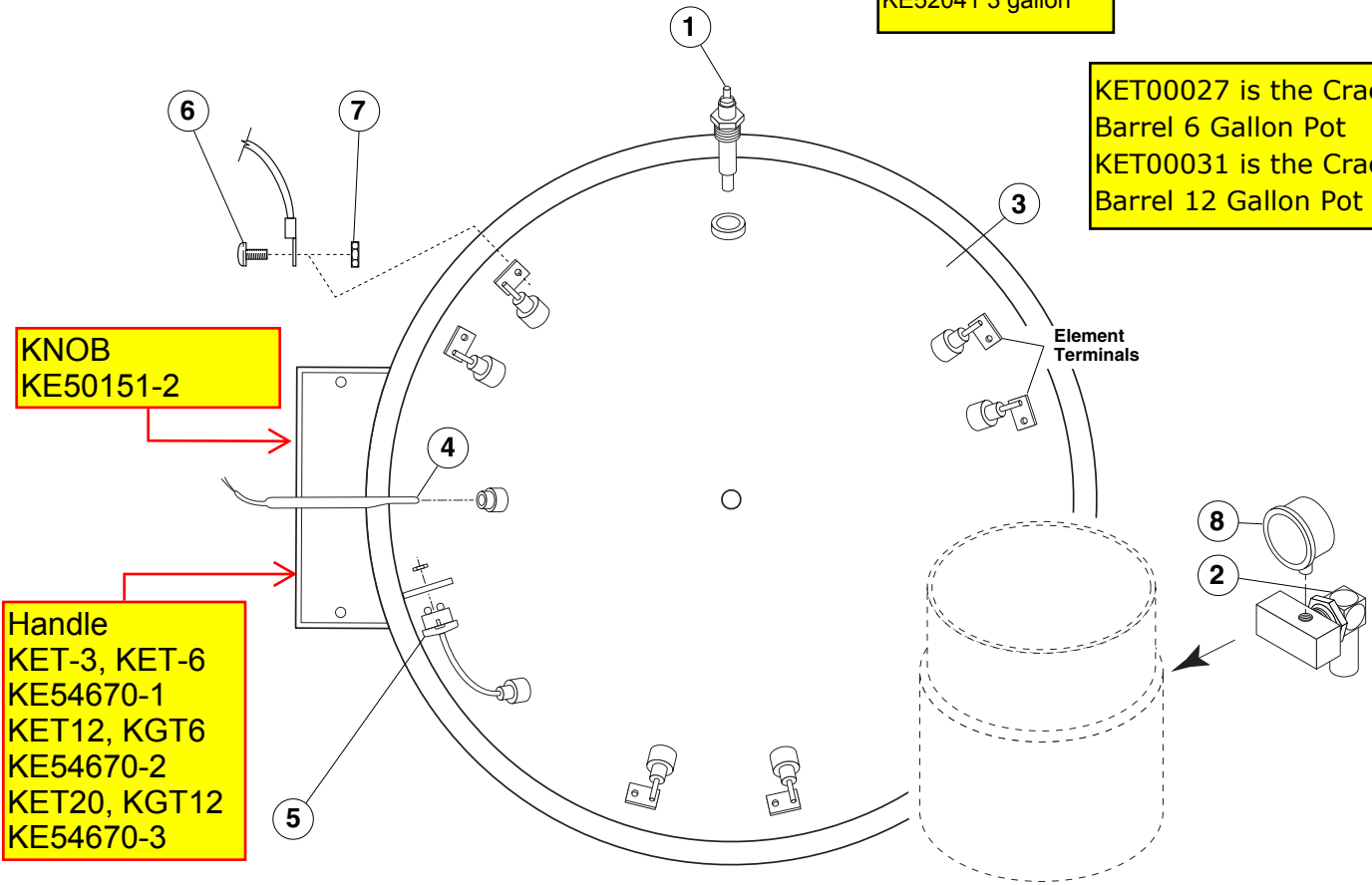

ITEM NO.	PART NO.	DESCRIPTION	QTY.
1.	KE50556-1	Probe, Low Water	1
2.	KE54941-5	Safety Valve, 50 PSI, 1/2" (North America)	1
	KE54941-31	Safety Valve, 50 PSI, 1/2", (Europe)	1
3.	KE52455	Bottom Cover Gasket, 3 gallon kettle	1
	KE52456	Bottom Cover Gasket, 6 gallon kettle	1
	KE52457	Bottom Cover Gasket, 12 gallon kettle	1
	KE52459	Bottom Cover Gasket, 20 gallon kettle	1
4.	KE00515	Thermistor Assembly	1
5.	KE55069-5	Safety Thermostat (140° C)	1
6.	FA11145	Screw	2-12
7.	FA21007	Nut	2-12
8.		<b>Pressure Gauge</b>	
	KE000714-4	For units built prior to February 2005	1
	KE50429-5	For units built after January 2005	1

# CORD & PLUG OPTION

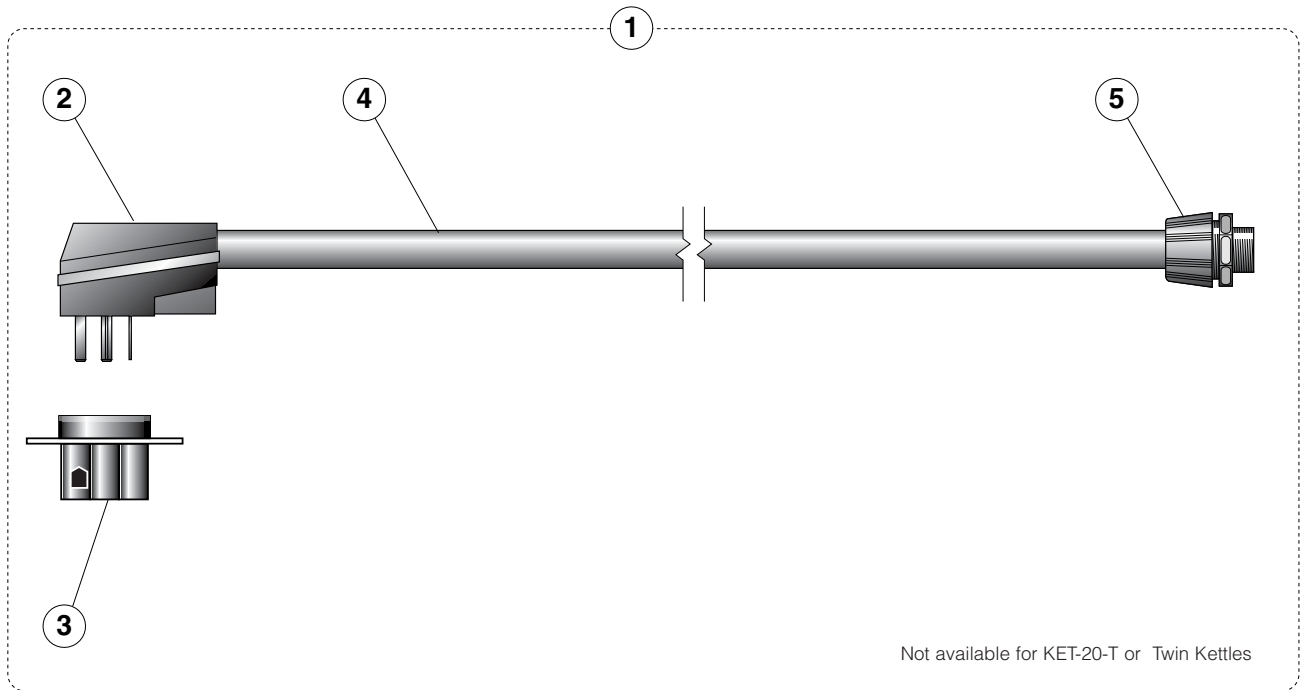

ITEM NO.	PART NO.	DESCRIPTION	QTY.
<b>FOR KET-6-T (SW)</b>			<i>(200-240VAC, 3PH, 50/60Hz)</i>
1.	KE02113-1	Cord Plug Assembly	1
2.	KE54819-1	Plug (30A)	1
3.	KE54820-1	Receptacle (30A)	1
4.	KE54821-2	Electrical Cord (10/4)	1
5.	KE54721-3	Cord Connector	1
<b>FOR KET-6-T (HW), KET-12-T (SW),</b>			<i>(200-240VAC, 3PH, 50/60Hz)</i>
1.	KE02113-2	Cord Plug Assembly	1
2.	KE54819-2	Plug (50A)	1
3.	KE54820-2	Receptacle (50A)	1
4.	KE54821-3	Electrical Cord (8/4)	1
5.	KE54721-4	Cord Connector	1
<b>FOR KET-12-T (HW)</b>			<i>(200-240VAC, 3PH, 50/60Hz)</i>
1.	KE02113-3	Cord Plug Assembly	1
2.	KE54819-2	Plug (50A)	1
3.	KE54820-2	Receptacle (50A)	1
4.	KE54821-4	Electrical Cord (6/4)	1
5.	KE54721-5	Cord Connector	1

# CONSOLE COMPONENTS & MARINE LOCK

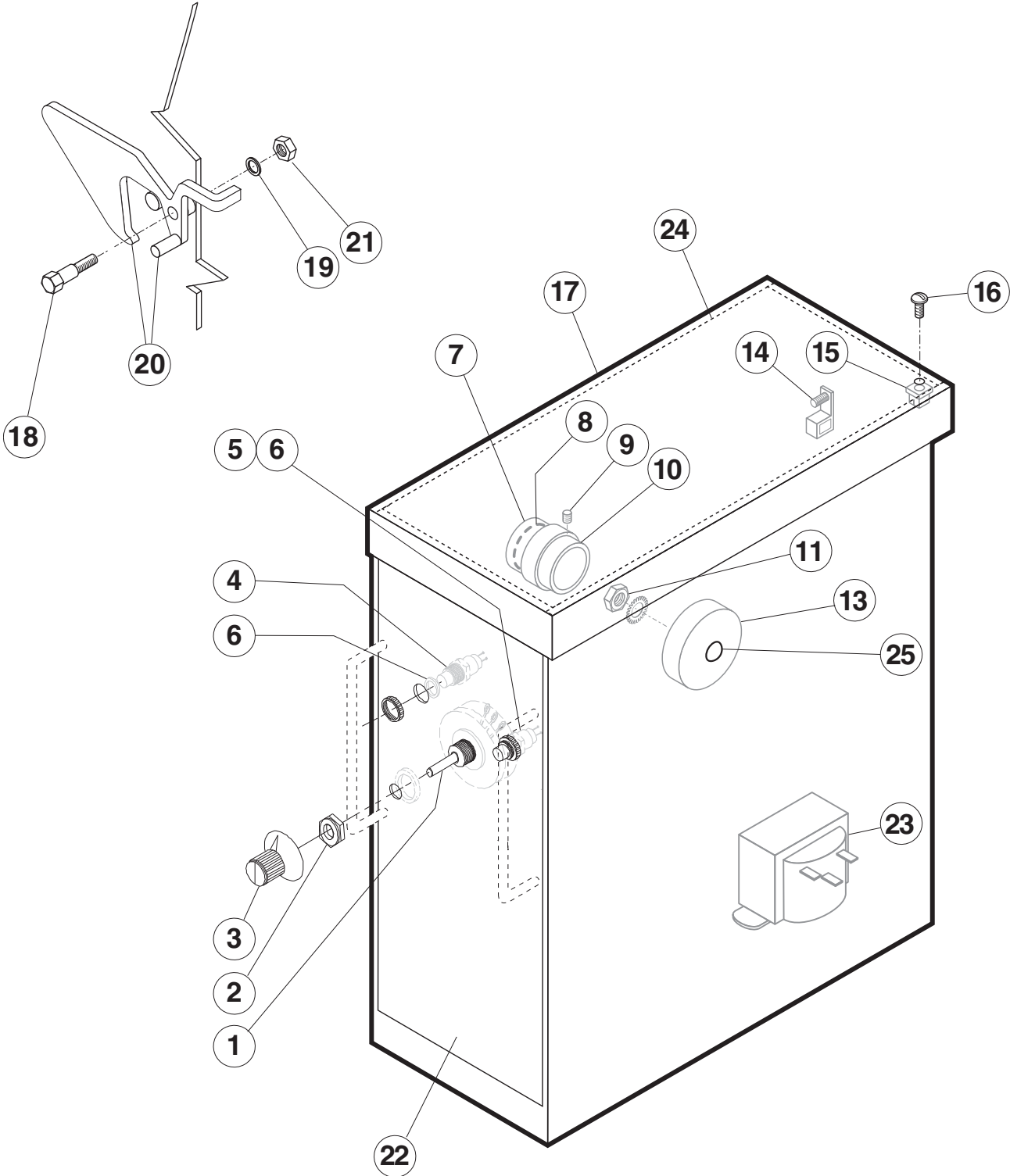

# CONSOLE COMPONENTS & MARINE LOCK

ITEM NO.	PART NO.	DESCRIPTION	QTY.
	SE00074	Potentiometer without ON/OFF Switch	Single / Twin
1.	SE00114	Potentiometer with ON/OFF Switch, c/w Item #2	1/2
2.	KE51005	Rubber Boot	1/2
3.	KE50569-1	Knob, Potentiometer	1/2
4.	SE003013-1	Red L.E.D Replacement Kit., (includes LED KE50567-1 & "O" Ring)	1/2
5.	SE003013-2	Green L.E.D Replacement Kit., (includes LED KE50567-3 & "O" Ring)	1/2
6.	FA05002-18	"O" Ring	2/4
7.	KE55319	bearing KET-TGB gearbox kettles	1/2
	KE54234	Bearing KET3.6,12,20-T kettles	1/2
8.	FA05002-20	"O" Ring	1/2
9.	FA19184	Allen Screw	2/4
10.	SK50047	Collar, Trunnion Lock	1/2
11.	FA21024	Hex Nut, 5/16-18	1/2
13.	KE01834	Bearing Assembly	1/2
14.	KE50473	Ground Lug	1/2
15.	FA95074	Nylon Anchor Nut	4
16.	FA95031	Screw	4
17.	KE54218	<b>Console Covers</b> (KET-3-T, KET-6-T, KET-12-T, KET-20-T, TKET-3-T)	1
	KE542181	(TKET-6-T, TKET-12-T)	1
		<b>Marine Lock</b> MARINE LOCK ASSEMBLY SE00099	
18.	FA15019-1	Hex Socket Shoulder Bolt	1/2
19.	FA31029	Split Lockwasher	1/2
20.	KE02078-1	Latch, Left Hand	1
	KE02078-2	Latch, Right Hand	1
21.	FA21008	Hex Nut, 1/4-20	1/2
22.		<b>Labels</b>	
	KE95555-1	(KET-3-T, KET-6-T, KET-12-T, KET-20-T)	1
	KE95555-3	(TKET-3-T)	1
	KE95555-4	(TKET-6-T, TKET-12-T)	1
23.		<b>Transformers</b>	
	KE53838-11	Transformer, 380 to 415v	1
	KE53838-12	Transformer, 440 to 480v	1
	KE53838-13	Transformer, 600v	1
24.	KE54846-1	Cover Gasket, KET- 3/6/12/20-T, TKET-3-T	1
	KE54846-2	Cover Gasket, TKET-6/12-T	1
25.	FA95073	Round Head Square Neck Bolt	1



# TILTING GEARBOX ASSEMBLY

(12 gallon kettle only, prior to January 2002)

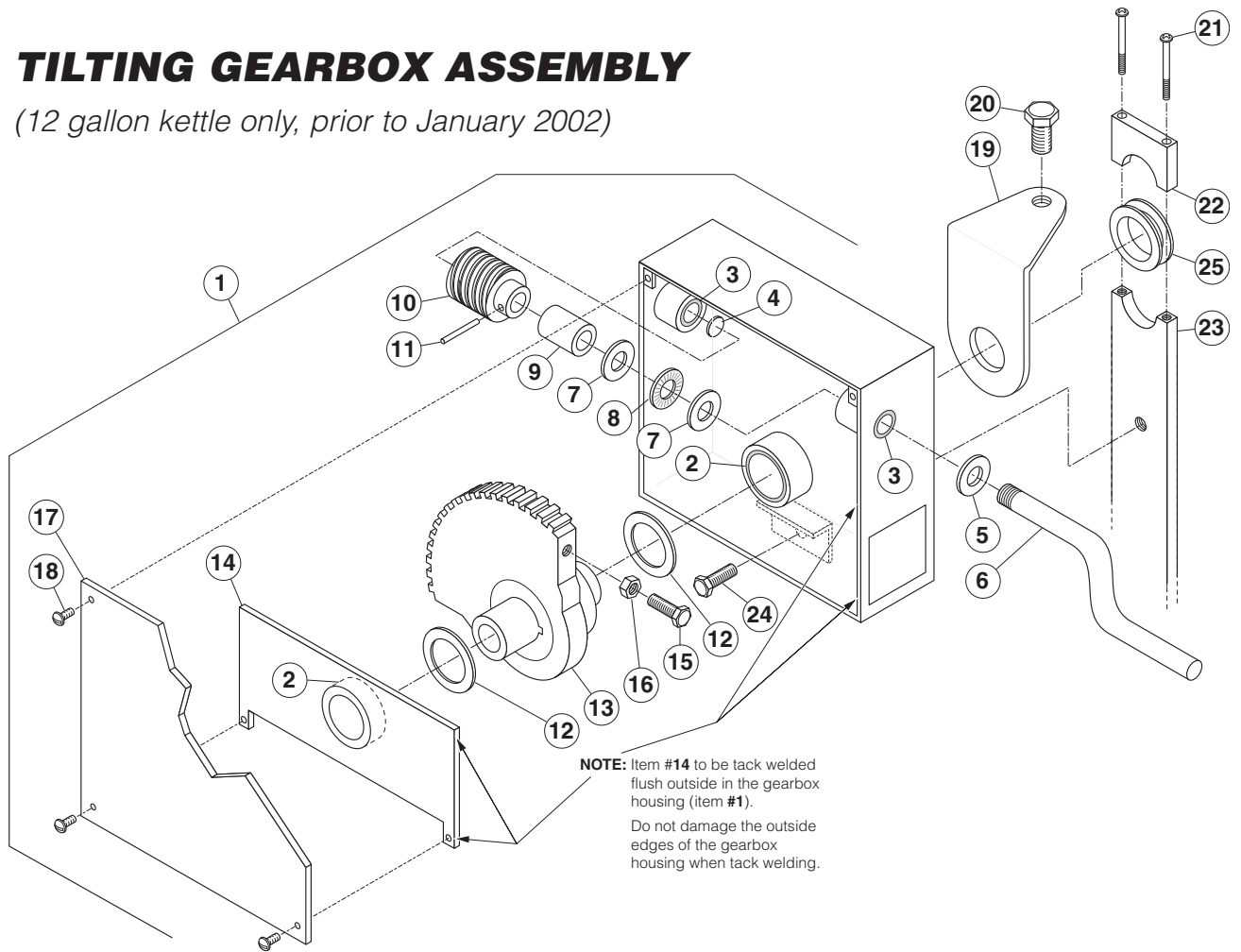

ITEM NO.	PART NO.	DESCRIPTION	QTY.
1.-16.	KE02062-1	TILTING GEARBOX ASSEMBLY	1
1.	KE02060	GEARBOX HOUSING	1
2.	KE50198	BEARING, TRUNNION	2
3.	KE54739-2	BEARING, TILT SHAFT	2
4.	KE54737	END HOUSING SPACER, TILT SHAFT, BRONZE	1
5.	KE50306-2	WASHER	1
6.	KE50306-1	TILT SHAFT	1
7.	KE52192	BEARING WASHER	2
8.	KE52191	BEARING	1
9.	KE50426-3	SPACER, WORM GEAR	1
10.	KE50315	WORM GEAR	1
11.	FA95005	TENSION PIN	1
12.	KE54738-1	WASHER	2
13.	KE02059	SEGMENT GEAR AND SPACER ASSEMBLY	1
14.	KE02061	TRUNNION BEARING HOUSING HOLDER ASSEMBLY C/W BEARING	1
15.	FA10485	HEX HEAD BOLT	1
16.	FA20008	HEX NUT	1
17.	KE54729	GEAR BOX COVER	1
18.	FA11146	BINDING HEAD SCREW, 8-32 X 3/8"	4
19.	KE54750-2	TILT BRACKET	1
20.	KE54732	HEX HEAD BOLT	1
21.		SCREW, #10-24 X 1 1/4"	2
22.	KE54656-4	SUPPORT BAR TOP - END	1
23.	KE02004-3	SUPPORT BAR	1
24.	KE54732	HEX HEAD BOLT	1
25.	SK50403-2	BRONZE BEARING	1

# TILTING GEARBOX ASSEMBLY

(3, 6, 12 & 20 gallon kettles, after January 2002)

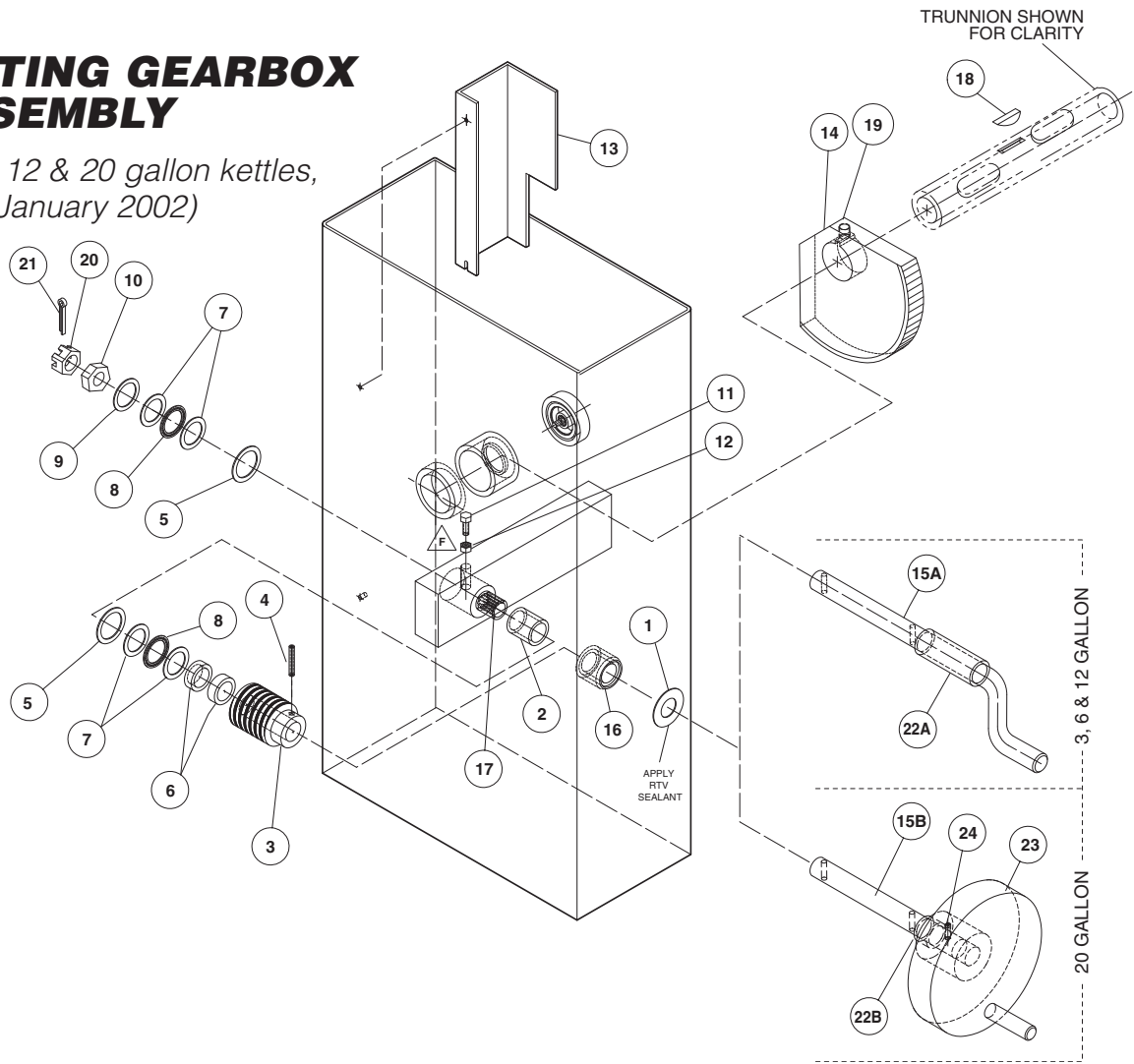

ITEM NO.	PART NO.	DESCRIPTION	QTY.
1.	KE54738-3	WASHER S.S. (SHAFT HOLE COVER)	1
2.	KE51738	BEARING SLEEVE FOR GEAR BOX	1
3.	KE50315	WORM GEAR	1
4.	FA95005	TENSION PIN	1
5.	KE51891	WASHER 1 1/2" O.D. X 13/16" I.D.	2
6.	KE52193-1	THRUST BEARING SPACER	2
7.	KE52192	THRUST WASHER	4
8.	KE52191	THRUST BEARING	2
9.	FA30088	TILT SHAFT WASHER	1
10.	FA95008	LOCK NUT 3/4-16	1
11.	FA19177	SET SCREW 5/16-24 X 1"	1
12.	FA20047	JAM HEX NUT 5/16-24	1
13.	KE54927	SUPPLY WIRE PROTECTION GUARD	1
14.	KE00151-2	SEGMENT GEAR	1
15A.	KE50306-2	TILT SHAFT (3, 6 & 12 GALLON)	1
15B.	KE50375	TILT SHAFT (20 GALLON)	1
16.	KE02057-1	TILT SHAFT BEARING ASSEMBLY	1
17.	KE50245	BEARING FOR GEARBOXES	1
18.	FA95083	WOODRUFF KEY #808	1
19.	FA19500-4	SET SCREW, 1/4-28 X 3/4	2
20.	KE55431	NUT, SLOTTED	1
21.	KE55432	COTTER PIN, 3/32 X 1 3/4	1
22A.	KE55433-1	SPACER, SAFETY (3, 6 & 12 GALLON)	1
22B.	KE55433-2	SPACER, SAFETY (20 GALLON)	1
23.	KE00508	HANDWHEEL ASSEMBLY	1
24.	FA19505	SET SCREW 3/8-24 X 3/8	1

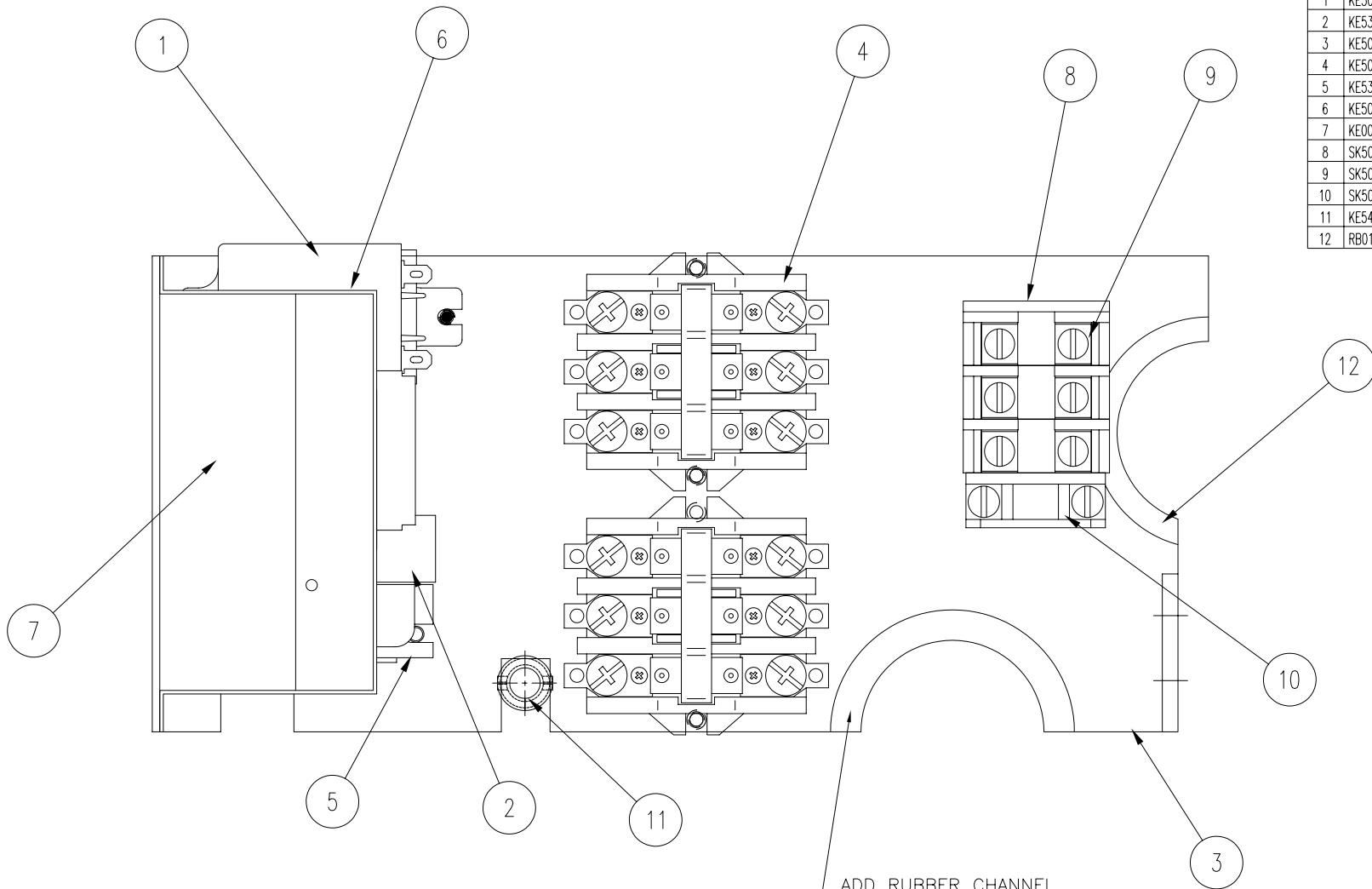

ITEM	PART_#	DESCRIPTION	QTY
1	KE50753-7	RELAY; SPDT/10A/12VDC	1
2	KE53838-21	TRANSFORMER;240P/16S 60HZ	1
3	KE50343-17	COMPONENT PLATE	1
4	KE50750-2	CONTACTOR (#41NB30AG)	2
5	KE53444	TRANSFORMER BRACKET	1
6	KE50303	ELECTRONIC BOX HOLDER	1
7	KE00458	KETTLE CONTROL BOX	1
8	SK50054-1	END BARRIER	1
9	SK50055-1	TERMINAL BLOCK	3
10	SK50054-2	END ANCHOR	1
11	KE54952	HEYCO OPEN/CLOSED BUSHING	1
12	RB01850	RUBBER GASKET	0.5

ADD RUBBER CHANNEL  
TO CIRCUMFERENCE IN ORDER TO  
PROTECT SHEATHING

# COMPONENT PLATE, MODIFIED, TRICKLE FAUCET

(for KET-12-T only)

KE003209-9 Switch Assembly,  
On/Off/On - Momentary

USE TIE-WRAP AROUND  
TIMER & COMPONENT PLATE  
TO SECURE

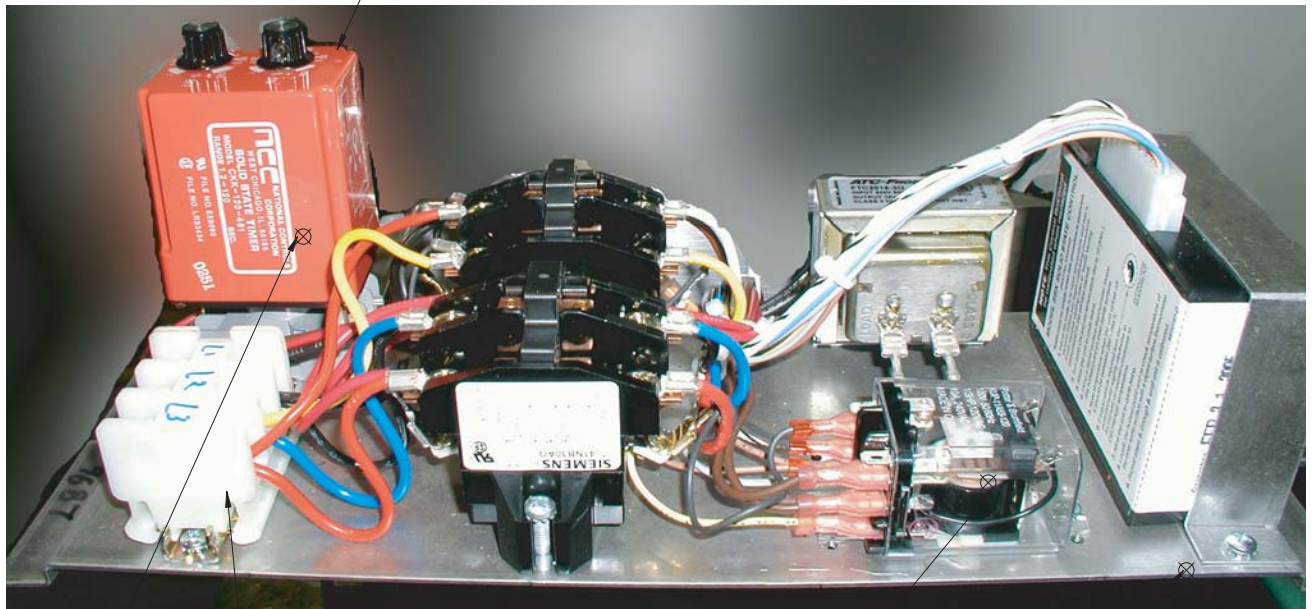

3

MOVE TERMINAL BLOCK  
AWAY FROM TIMER  
(DRILL & TAP NEW HOLES  
AS NECESSARY)

2

1

**NOTE:** USE KE00224 TO MODIFY

ITEM NO.	PART NO.	DESCRIPTION	QTY.
1.	KE00224	COMPONENT PLATE ASSEMBLY	1
2.	KE50753-8	RELAY, DPDT 12 VDC, REPLACES KE50753-7	1
3.	KE001057	TIMER ASSEMBLY, SOLID STATE	1

# PLUMBING, TRICKLE FAUCET

(for KET-12-T only)

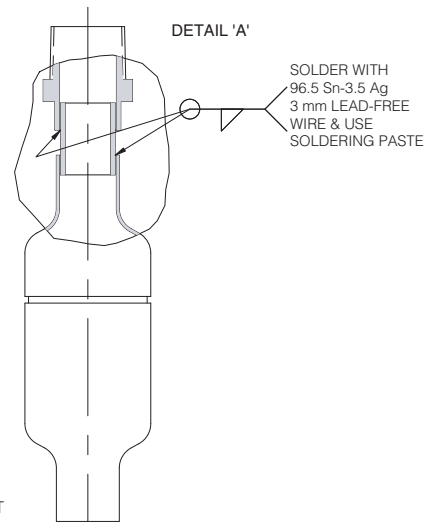
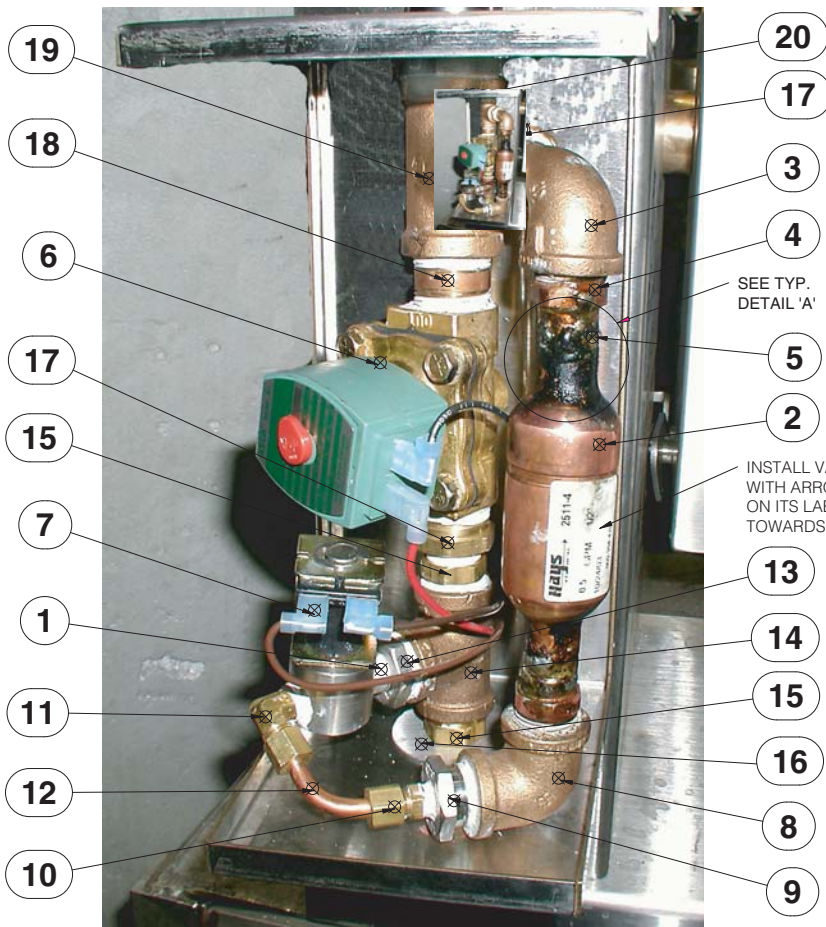

SEE TYP. DETAIL 'A'

INSTALL VALVE WITH ARROW ON ITS LABEL TOWARDS SPOUT

**NOTE:** WRAP BALANCING VALVE WITH A WET RAG WHILE SOLDERING TO AVOID BURNING OF INSIDE RUBBER LINING OF VALVE

ITEM NO.	PART NO.	DESCRIPTION	QTY.
1.	KE601160	NIPPLE; 1/4 NPT X 7/8 BRASS	1
2.	KE601045	AUTO BALANCING VALVE	1
3.	FI05025	STREET ELBOW, 1/2" PLATED	1
4.	KE601046	SWEAT FITTING, COPPER, 1/2 NPT MALE X 1/2 FEMALE	2
5.	KE601047	COPPER PIPE INSERT	2
6.	KE54834-5	SOLENOID VALVE	1
7.	KE54834-15	SOLENOID VALVE	1
8.	FI00062	1/2 ELBOW, BRASS	1
9.	KE601049	ADAPTOR, 1/2 NPT M X 1/8 NPT F	1
10.	FI05199-6	COMPRESSION FITTING, 1/8 MPT X 1/4 TUBE	1
11.	FI05198-4	COMPRESSION ELBOW, 1/4 TUBE X 1/4 MPT	1
12.	KE601050	COPPER TUBING	1
13.	KE601052	ADAPTOR, 1/2 NPT M X 1/4 NPT F	1
14.	FI00178	BRASS TEE, 1/2	1
15.	FI00596	BRASS NIPPLE, 1/2 X 1 1/2	2
16.	KE54353	WASHER	1
17.	FI00356	REDUCER 3/4 X 1/2	2
18.	FI00629-36	BRASS NIPPLE, 3/4 X 1 1/2 LONG	1
19.	FI00179	BRASS TEE, 3/4	1
20.	SD50098	LOCKNUT, GALVANIZED, 3/4	1

# ELECTRICAL PANEL

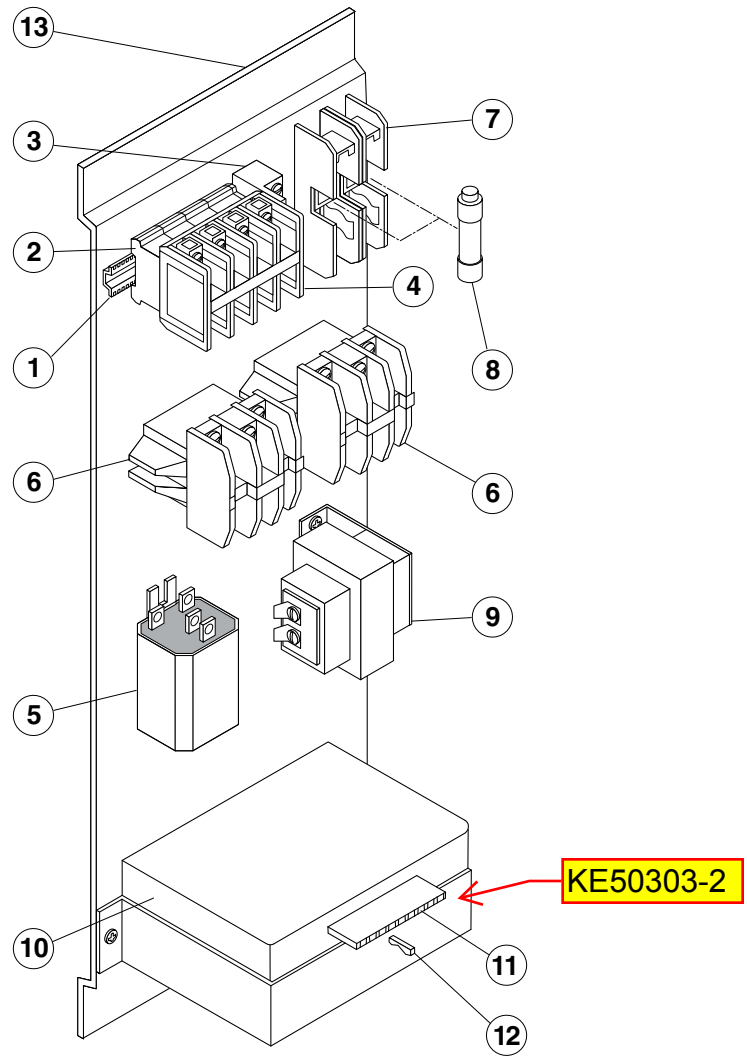

ITEM NO.	PART NO.	DESCRIPTION	QTY.
			Single / Twin
1.	KE54761	Terminal Block Mounting Strip	1 / 2
2.	SK50055-1	Terminal Block	3 / 6
3.	SK50054-2	Terminal Block End Anchor	1 / 2
4.	SK50054-1	Terminal Block End Barrier	1 / 2
5.	KE50753-7	Relay	1 / 2
6.	KE50750-2	Contactor, 208-240v	2 / 4
7.	KE51139-1	Fuse Holder (480v only)	2 / 4
8.	KE52936-1	Fuse (480v only)	2 / 4
9.	KE53838-21	Transformer	1 / 2
10.	KE00458	Kettle Control Box	1 / 2
11.	KE51225	Edge Connector, 10 Pin	1 / 2
12.	KE51226	Wire Connector Terminal	10 / 20
13.	KE50343-1	Component Mounting Plate	1 / 2



# MAINTENANCE

*ALL SERVICE MUST BE PERFORMED BY A QUALIFIED SERVICE TECHNICIAN.*

**IMPORTANT!**  
**ENSURE KETTLE IS AT ROOM TEMPERATURE AND  
PRESSURE GAUGE IS SHOWING ZERO OR LESS PRESSURE  
PRIOR TO REMOVING ANY FITTINGS.**

Cleveland Range equipment requires little preventative maintenance. We do however provide the following chart as a guideline for inspection and maintenance to keep your unit functioning at 100%.

## INSPECTION AND MAINTENANCE CHECK LIST

The following check should be completed every six months or more frequently if unit is in a high volume facility.

**WARNING:** It is imperative that damaged seals be repaired immediately to prevent equipment failure and/or damage.

<b>ITEM</b>	<b>CHECK</b>
<b>CONSOLE COVER SEAL</b>	Insure there are four screws firmly holding down the cover. If not replace screws and/or missing or worn nylon anchor nuts.
<b>BOTTOM COVER GASKET</b>	Check to see it is in place and is not cracked or split.
<b>TILTING</b>	Check that kettle tilts smoothly. Grease as described in Bearing Lubrication Procedure.
<b>TILT HANDLE</b>	Check handle for tightness. If loose apply lock tight and reinstall. Check handle knob is on end of handle and firmly tightened. If loose apply lock tight and reinstall.
<b>PRESSURE GAUGE</b>	Check that the gauge does not have moisture on its inside face. Replace if moisture is present. Check that the gauge shows a vacuum (needle is well into the Green zone) when cold and shows between 25-40 psi when unit is hot. If not follow Vacuum Leak Test Procedure.
<b>PRESSURE RELIEF VALVE</b>	Check pressure relief valve as described in Pressure Relief Valve Periodic Testing Procedure.
<b>TEMPERATURE CHECK</b>	Following Calibrating Procedure check the inner kettle surface temperature with a digital surface thermometer and adjust if required.



# BEARING LUBRICATING PROCEDURE

1. Remove console cover.

2. Loosen two Allen screws on locking ring.

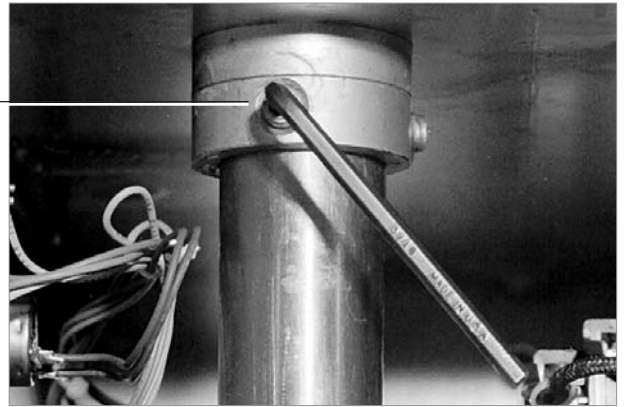

3. Pull locking ring to center of trunnion.

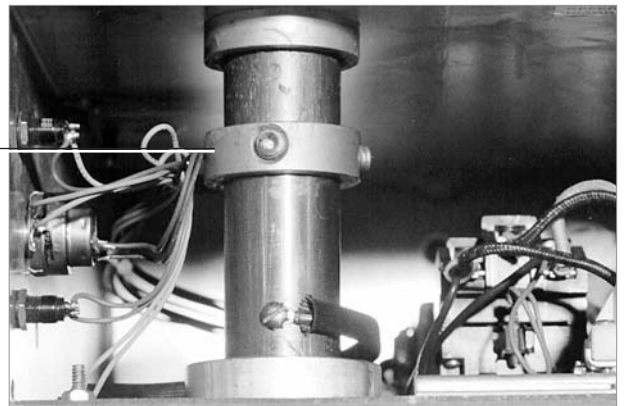

4. Pull kettle two inches away from console and rest on support block.

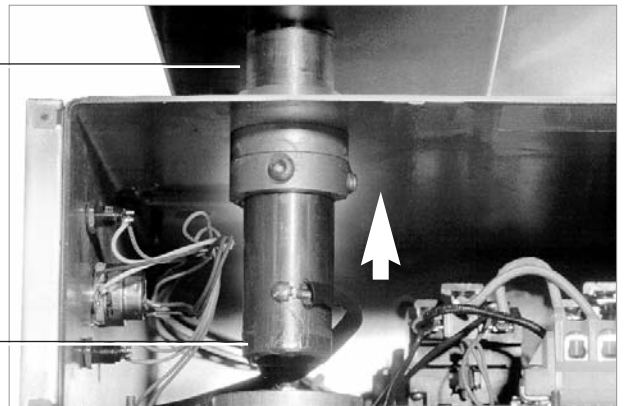
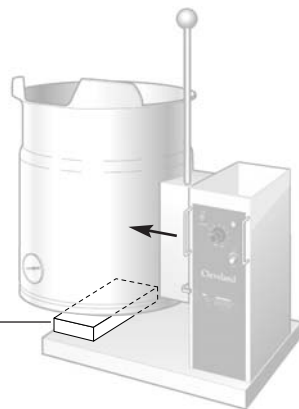

5. Clean newly exposed sections of trunnion.

6. Grease trunnion between kettle and console.

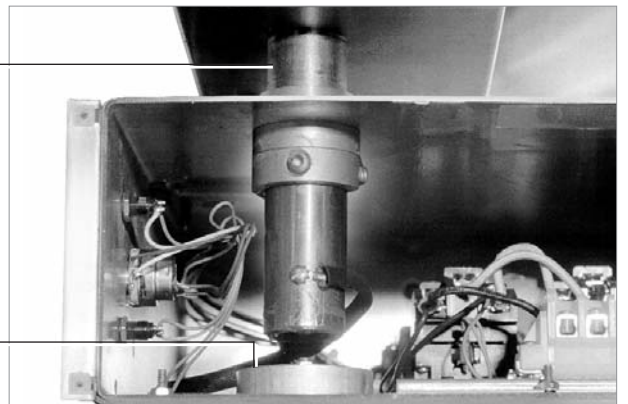

7. Repack outer needle bearing.

8. Push kettle back in place.

10. Reinstall trunnion and lock collar.

11. Replace console cover.

## CALIBRATING PROCEDURE

1. Insure the unit has a vacuum before you begin calibrating procedures. If unit requires venting refer to KETTLE VENTING INSTRUCTIONS.
2. Set On-Off Switch/Temperature Control to "10" (Max.).
3. Allow the unit to cycle twice.
4. Check temperature of the inner kettle surface with a digital surface thermometer.
5. Temperature should be between 260° F and 265° F.
6. Using a screw driver adjust temperature by turning the potentiometer on the black box. Turn very little. Turn clockwise to INCREASES and counter-clockwise to DECREASE temperature.
7. Allow the unit to cycle twice.
8. Check temperature of the inner kettle surface with a digital surface thermometer.
9. Repeat steps 4. through 8. until unit is calibrated.

Pressure Relief Valve/Gauge Assembly Drawing

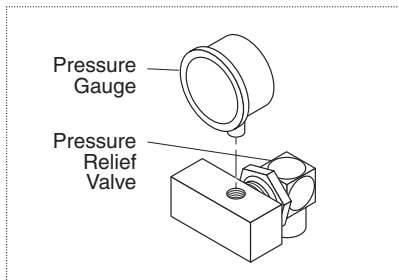

## PRESSURE RELIEF VALVE PERIODIC TESTING PROCEDURE

Most insurance agencies require periodic testing of

**WARNING: IMPROPER REFILLING OF KETTLE JACKET WILL RESULT IN IRREVERSIBLE DAMAGE TO UNIT.**

pressure relief valves used on pressure vessels. This procedure will allow you to safely and quickly test your kettle's pressure relief valve. We recommend this test be performed twice a year.

**NOTE:** The following instruction is intended for use by qualified service personnel.

**WARNING:** Kettle surface will be hot and steam will be released during testing. Take necessary precautions including the use of gloves and eye protection to prevent personal injury.



**DANGER: PRESSURE RELIEF VALVE WILL EXHAUST HIGH TEMPERATURE STEAM. CONTACT WITH SKIN COULD RESULT IN SERIOUS BURNS. KEEP FACE, HANDS AND BODY CLEAR OF DISCHARGE.**



**DANGER: WORKING ON MACHINES WITH POWER COULD RESULT IN SEVERE ELECTRICAL SHOCK.**

1. With the kettle empty, set On-Off Switch/Temperature Control to "10" (Max.). Allow the kettle to heat until the unit cycles off.
2. Switch On-Off Switch/Temperature Control to "0" (Off) and disconnect main power at fused disconnect switch.

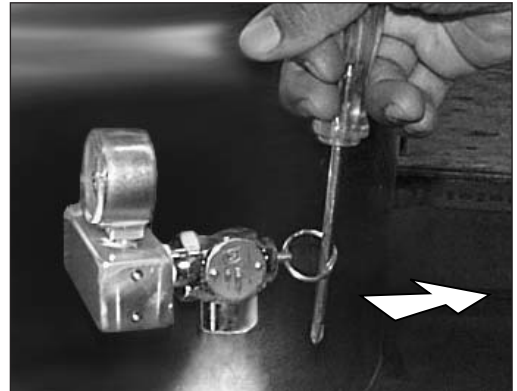

3. Stand to the side of the pressure relief valve discharge tube and pull valve open for a maximum of one second. Repeat test three to four times. Each time the mechanism should move freely and be accompanied by a rapid escape of steam.

If valve appears to be sticking replace pressure relief valve.

If foreign material is discharged then drain kettle and replace pressure relief valve.

See KETTLE JACKET CLEANOUT AND PASSIVATION PROCEDURES for full instructions on the correct method for refilling kettle jacket.

**WARNING:** Improper refilling of kettle jacket will result in irreversible damage to unit.

**NOTE:** Rust inhibitor is purchased locally. Read directions and do not exceed manufacturer's recommendation (excessive rust inhibitor can also cause solidification).

## RESERVOIR FILL PROCEDURES

The kettle's water level must be maintained at the proper level to submerge the heater elements. Under normal operating conditions, the sealed water reservoir should never require the addition of water.

If the red "low water" light comes on during use (while the kettle is in an upright position), the water level has reached a critically low level. The low water protection control has automatically shut off the heater elements. The following procedure must be completed before further use:

**NOTE:** Have a qualified service technician repair the leakage problem and add water to the unit. Ensure that the red "low water" light is on when the kettle is upright. On tilting kettles, it is normal for the red light to come on when the kettle is in a tilted position, as the elements are not submerged in water at this point.

### DISTILLED WATER REQUIREMENTS

Kettle Capacity	When Red "Low Water Light" comes on, add Distilled Water
<b>3 gallon</b>	50 ounces
<b>6 gallon</b>	70 ounces
<b>12 gallon</b>	120 ounces
<b>20 gallon</b>	1 gallon

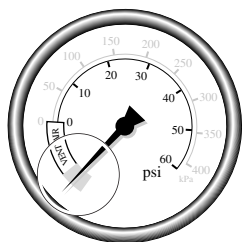

1. Ensure kettle is at room temperature and pressure gauge showing zero or less pressure.
2. Shut off power to the kettle at the fused disconnect switch.

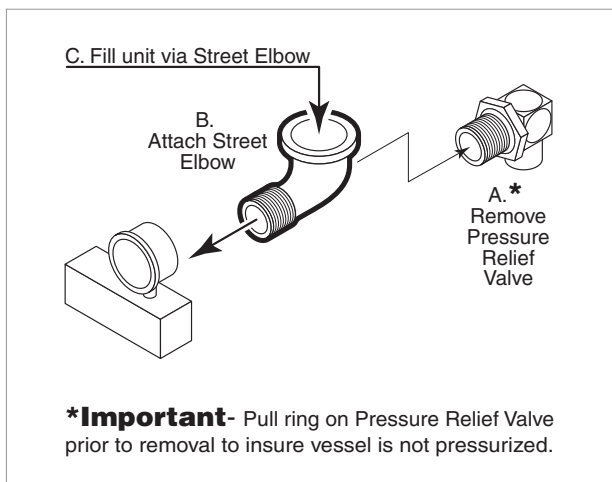

Pressure Relief Valve/Gauge Assembly Drawing

3. Pull Pressure Relief Valve (A) open to insure vessel is not pressurized.
4. Remove Pressure Relief Valve (A).
5. Replace Pressure Relief Valve (A) with Street Elbow (B).
6. Add distilled water (C) through the Street Elbow (B), using a funnel if necessary. Refer to **Distilled Water Requirements** chart for the proper amount required.
7. Apply a thread sealant (i.e. Teflon tape) to the Pressure Relief Valve's (A) thread and replace.
8. Restore power to unit at the fused disconnect switch.
9. The kettle must now be vented. (Refer to the KETTLE VENTING INSTRUCTIONS).

## KETTLE VENTING INSTRUCTIONS

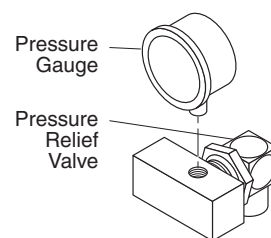
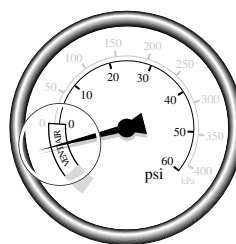

The following venting procedure should be followed when the Vacuum/Pressure Gauge needle is in the "VENT AIR" zone:

**NOTE:** Check for and eliminate leaks prior to venting (See REPAIRING LEAKS IN STEAM JACKETED KETTLE FITTINGS).

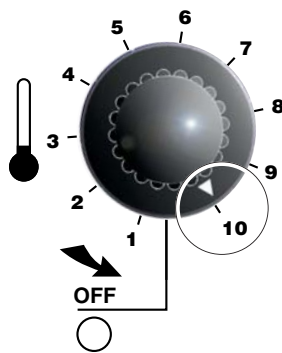

1. Set On-Off Switch/Temperature Control to "10" (Max.). Heat the empty kettle until unit cycles off.
2. Vent kettle by pulling safety valve ring 8-10 times in short 2-3 second blasts with a 5 second interval between pulls.

**NOTE:** If unit cycles ON, stop venting and wait for kettle to cycle OFF before continuing.

3. Turn kettle OFF. Add cold water to kettle until its surface temperature is below 100°F. The pressure gauge needle should be in the green zone, indicating a vacuum in the kettle's jacket.

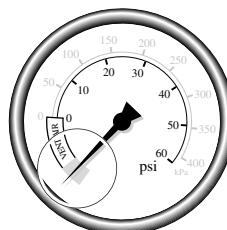

## VACUUM LEAK TEST PROCEDURE

If the kettle will not hold vacuum, test for leaks at:

- A.** Water Level Probe (remove bottom cover).
- B.** Pressure Relief Valve.
- C.** Pressure Gauge.

### LEAK TEST PROCEDURE:

- 1.** Heat kettle until unit cycles off.
- 2.** Shut off power to the kettle at the fused disconnect switch.
- 3.** Spread Bubble Type Leak Detector over suspected areas and watch closely for bubbles.
- 4.** Repair areas as required.

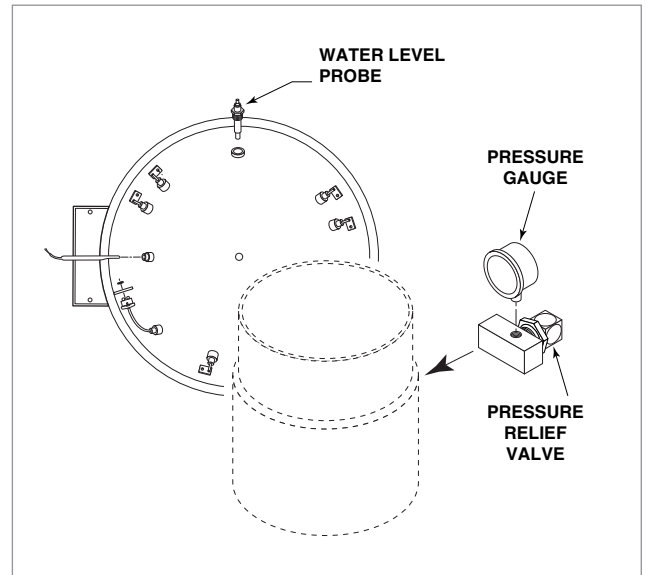

## REPAIRING LEAKS IN STEAM JACKETED KETTLE FITTINGS

If unit will not hold a vacuum the most likely cause is a leak at one of the fittings.

Often, the easiest way to eliminate a leak is reseal the suspect areas.

- 1.** Water Level Probe                      Remove, clean threads, apply teflon thread sealant and reinstall.
- 2.** Pressure Relief Valve                  **A/** Inspect for signs of leaks. Replace if required.  
   **B/** Remove, clean threads, apply teflon thread sealant and reinstall.
- 3.** Pressure Gauge                          **A/** Inspect face of gauge. If it contains moisture on the inside of face replace.  
   **B/** Remove, clean threads, apply teflon thread sealant and reinstall.

# KETTLE JACKET CLEANOUT AND PASSIVATION PROCEDURES

The following procedure should be performed at least once every three years to prevent possible corrosion and ensure the optimum life of the kettle.

**WARNING:**  
IMPROPER REFILLING OF KETTLE JACKET WILL RESULT IN IRREVERSIBLE DAMAGE TO UNIT.

**DANGER:**  
MOLYFILM 315 IS CORROSIVE, AVOID CONTACT WITH SKIN AND EYES.

**DANGER:**  
AVOID INHALATION - VAPORS FROM MOLYFILM 315 MAY BE HARMFUL OR FATAL.

**DESCRIPTION** - Molyfilm 315 inhibits corrosion in stainless steel and copper. A pH buffer is present to assist in maintaining the appropriate pH to assist in corrosion inhibition.

**DISPOSAL** - Follow all Federal, State and local codes when disposing of product.

**SHELF LIFE** - Molyfilm 315's effectiveness will diminish after three years.

**REFILL QUANTITIES** (ORDERING INFO: 1 Liter Molyfilm 315 Rust Inhibitor)

**IMPORTANT:** To ensure satisfactory mixing follow the MIXING / FILLING PROCEDURE described below.

Kettle Size	Volume of Water		Volume of Molyfilm 315	
	U.S. Gal.	Liters	oz.	cc (ml.)
3 U.S. Gal.	0.5	1.8	0.7	19
6 U.S. Gal.	1.3	4.9	1.8	51
12 U.S. Gal.	2	7.6	2.8	80
20 U.S. Gal.	3.8	14.2	5.1	150

## MIXING / FILLING PROCEDURE

1. Refer to chart to determine the required volumes of water and Molyfilm 315.
2. In a separate container mix 1/2 gallon of the required volume of water with the total required volume of Molyfilm 315.
3. Pour mixture into kettle.
4. Pour the remaining required volume of water into kettle.

**DANGER:**  
PRESSURE RELIEF VALVE WILL EXHAUST HIGH TEMPERATURE STEAM. CONTACT WITH SKIN COULD RESULT IN SERIOUS BURNS. KEEP FACE, HANDS AND BODY CLEAR OF DISCHARGE.

**DANGER:**  
WORKING ON MACHINES WITH POWER COULD RESULT IN SEVERE ELECTRICAL SHOCK.

**DANGER:**  
EXTREMELY HOT SURFACES. WORK ONLY ON COLD KETTLE.

## FLUSHING PROCEDURE

**WARNING:** The fused disconnect switch must be off before removing the kettles bottom cover.

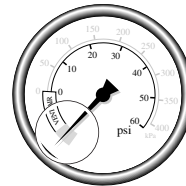

1. Ensure kettle is at room temperature and pressure gauge showing zero or less pressure.
2. Shut off power to the kettle at the fused disconnect switch.
3. Pull pressure relief valve ring open to insure vessel is not pressurized.
4. Pull pressure relief valve ring open to insure vessel is not pressurized.
5. Remove pressure relief valve.
6. Replace pressure relief valve with street elbow.
7. Remove bottom cover from kettle.
8. Remove low water level probe and allow water to drain.
9. Add water through the street elbow and flush out as much debris as possible with water.
10. Apply a thread sealant (i.e. Teflon tape) to the low water level probe threads and replace.
11. Fill kettle jacket with a mixture of water and Molyfilm 315 (see REFILL QUANTITIES chart).
12. Remove street elbow.
13. Apply a thread sealant (i.e. Teflon tape) to the pressure relief valve's thread and replace.
14. Turn kettle on, vent and heat on high for 1/2 hour.
15. Cool and drain kettle as per above procedure.

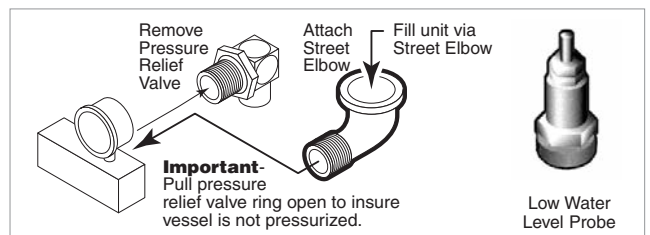

## REFILLING UNIT

1. Apply a thread sealant (i.e. Teflon tape) to the low water level probe threads and replace.
2. Fill kettle jacket with a mixture of water and Molyfilm 315 (see REFILL QUANTITIES chart).
3. Remove street elbow.
4. Apply a thread sealant (i.e. Teflon tape) to the pressure relief valve's thread and replace.
5. Restore power to unit at the fused disconnect switch.
6. Vent kettle. See Kettle Venting Instructions for proper procedure.

# DIAGNOSTIC GUIDE

This section contains servicing information intended for use by Authorized Service Personnel.

**NOTE 1:** If Fault Isolation Procedure is required, be sure to start at step #1.

**NOTE 2:** On table type kettles the entire control mounting panel may be removed from kettle control housing for easier troubleshooting and parts replacement.

**A/ Problem:** Kettle is not heating at all. (Kettle must be on and temperature control set.)

## Possible Causes

- |                                    |  |  |
|------------------------------------|--|--|
| <b>1.</b> No incoming power.       | <b>6.</b> Defective safety thermostat.                   | <b>10.</b> Defective thermistor.             |
| <b>2.</b> Kettle is tilted.        | <b>7.</b> Defective contactor/s.                         | <b>11.</b> Defective 240/16 VAC transformer. |
| <b>3.</b> Low water condition.     | <b>8.</b> Defective potentiometer (temperature control). | <b>12.</b> Defective control box.            |
| <b>4.</b> Defective ON/OFF switch. | <b>9.</b> Defective low water level probe.               | <b>13.</b> Defective elements.               |
| <b>5.</b> Defective 12 VDC relay.  |  |  |

## Fault Isolation Procedure

Step	Test	Result	Remedy
<b>1.</b>	Is there proper incoming voltage at terminal block?	Yes	Go to step #2.
		No	Correct external power supply problem.
<b>2.</b>	Is the red LED illuminated?	Yes	Follow Reservoir Fill Procedure. If this does not correct the problem, go to Problem <b>D</b> .
		No	Go to step #3.
<b>3.</b>	Is the green LED illuminated?	Yes	Go to step #4.
		No	Go to step #7.
<b>4.</b>	Do both contactors energize?	Yes	Check contactor contacts for pitting. Voltage across contactor terminals while in a closed position indicates a poor contact. Replace contactor/s as necessary. Check elements for short at ground or an open circuit. If element/s are defective contact the factory. Elements are not field replaceable.
		No	Go to step #5.
<b>5.</b>	Measure continuity across safety thermostat. Is it an open circuit?	Yes	Replace defective safety thermostat.
		No	Go to step #6.
<b>6.</b>	Is there 120 VAC present across the coils of the contactors?	Yes	Replace defective contactor/s.
		No	Go to step #6.
<b>7.</b>	Remove wire from low water level probe and ground it to the body of the kettle. Do the contactors now energize?	Yes	Clean or replace defective low water level probe. Replace defective red LED.
		No	Go to step #8.
<b>8.</b>	Is there 16 VAC present at output of 16 VAC transformer?	Yes	Go to step #9.
		No	Replace defective 240/16 VAC transformer.



<b>9.</b>	Measure continuity of ON/OFF switch/temperature control. Is it operating properly?	Yes No	Go to step <b>#10</b> . Replace defective ON/OFF switch/temperature control.
<b>10.</b>	Unplug control box and measure the resistance across potentiometer. Is it approximately 0 ohms at maximum setting and 50,000 ohms at minimum?	Yes No	Go to step <b>#11</b> . Replace defective potentiometer (ON/OFF switch/temperature control)
<b>11.</b>	Remove edge connector from control box. While kettle is cold or thermistor is removed and allowed to cool, measure the resistance between edge connector's pins #2 and #7. Is it approximately 100,00 ohms?	Yes No	Spray contact cleaner on control box terminals and edge connector. Try box again, if the problem still exists, replace defective control box. Replace defective thermistor.

**B/ Problem:** Kettle heats too slowly or not hot enough. (**Note:** normal max. operating pressure with an empty kettle is 30-35 psi.)

**Possible Causes**

- |   |  |                                  |
|---|--|----------------------------------|
| <b>1.</b> Air in jacket requires venting. | <b>3.</b> Defective potentiometer (temperature control). | <b>5.</b> Defective contactor/s. |
| <b>2.</b> Defective safety thermostat.    | <b>4.</b> Defective thermistor.                          | <b>6.</b> Defective control box. |
|   |  | <b>7.</b> Defective elements/s.  |

**Fault Isolation Procedure**

<b>Step</b>	<b>Test</b>	<b>Result</b>	<b>Remedy</b>
<b>1.</b>	In a cold state, does the pressure gauge read in the green zone?	Yes No	Go to step <b>#2</b> . There is air present in the jacket of the kettle. Follow Kettle Venting Procedure. If constant venting is required, there is a leak that should be corrected.
<b>2.</b>	Do the contactors shut off too early? (before reaching normal maximum operating pressure.)	Yes No	Go to step <b>#3</b> . Check contactor contacts for pitting. Voltage across terminal of contactor while energized signifies a poor contact. Replace contactor/s as necessary. Check elements for short to ground or open circuit. If elements are defective, contact the factory. Elements are not field replaceable.
<b>3.</b>	Does the green LED remain illuminated after the contactors shut off?	Yes No	Replace defective safety thermostat. Go to step <b>#4</b> .
<b>4.</b>	Unplug control box and measure the resistance across potentiometer (temperature control). Is it approximately 0 ohms at maximum and 50,000 ohms at minimum setting?	Yes No Yes	Go to step <b>#5</b> . Replace defective thermistor. Go to step <b>#6</b> .



<b>5.</b>	Remove kettle thermistor and allow to cool. Remove edge connector from control box. Test resistance across edge connector's pins #2 and #7. Is it approximately 100,000 ohms?	No	Replace defective thermistor
<b>6.</b>	Turn the potentiometer on the control box clockwise to increase the maximum operating temperature. Does the kettle now achieve maximum operating pressure of 30-35 psi in an empty kettle?	Yes No	Kettle is operating correctly. Spray contact cleaner on control terminals and edge connector. Try box again. If problem still exists, replace defective control box.

**C/ Problem:** Kettle is overheating.

**Possible Causes**

- |                                |  |                                   |
|--------------------------------|--|-----------------------------------|
| <b>1.</b> Defective thermistor | <b>2.</b> Defective potentiometer (temperature control). | <b>3.</b> Defective 12 VDC relay. |
|                                |  | <b>4.</b> Defective control box.  |

**Fault Isolation Procedure**

<b>Step</b>	<b>Test</b>	<b>Result</b>	<b>Remedy</b>
<b>1.</b>	Does the green LED turn off even though the contactors remain energized?	Yes No	Replace defective 12 VDC relay. Go to step #2.
<b>2.</b>	Unplug the control box and measure the resistance across the potentiometer (temperature control), Is the resistance approximately 0 ohms at maximum and 50,000 ohms at minimum setting?	Yes No	Go to step #3. Replace defective thermistor.
<b>3.</b>	Remove kettle thermistor and allow to cool. Remove edge connector from control box. Test resistance across edge connector's pins #2 and #7. Is it approximately 100,000 ohms?	Yes No	Go to step #4. Replace defective thermistor.
<b>4.</b>	Turn the potentiometer (temperature control) on the control box counter-clockwise to decrease the maximum operating temperature. does the kettle continue to overheat?	Yes No	Spray contact cleaner on control box terminal and edge connector. Try box again. If problem still exists, replace defective control box. Kettle is operating correctly.

**D/ Problem:** Red LED remains illuminated even though water has been added.

**Possible Causes**

- |   |                                  |
|---|----------------------------------|
| <b>1.</b> Defective low water level probe | <b>2.</b> Defective control box. |
|---|----------------------------------|

**Fault Isolation Procedure**

<b>Step</b>	<b>Test</b>	<b>Result</b>	<b>Remedy</b>
<b>1.</b>	Remove wire from low water level probe and ground the wire to the body of the kettle. Does the red LED turn off?	Yes No	Replace or clean defective low water level probe. Spray contact cleaner on control box terminals and edge connector. Try box again. If problem still exist, replace defective control box.

# WIRING DIAGRAM

## 3 Gallon Kettles

200-240v

Single Phase Only

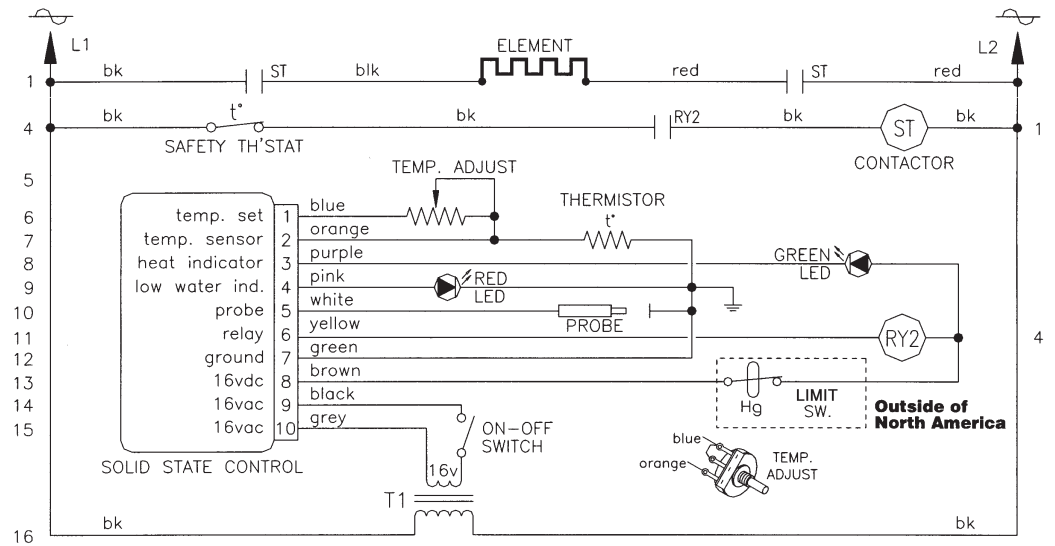

380-480v

Single Phase Only

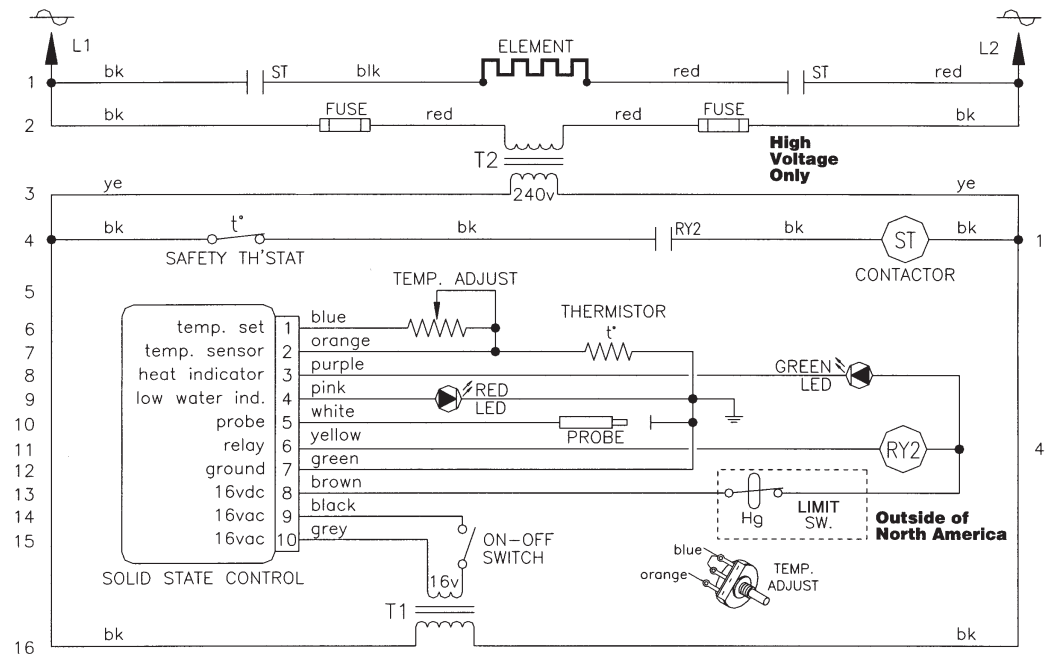

# WIRING DIAGRAM

## 6-20 Gallon

200-240v

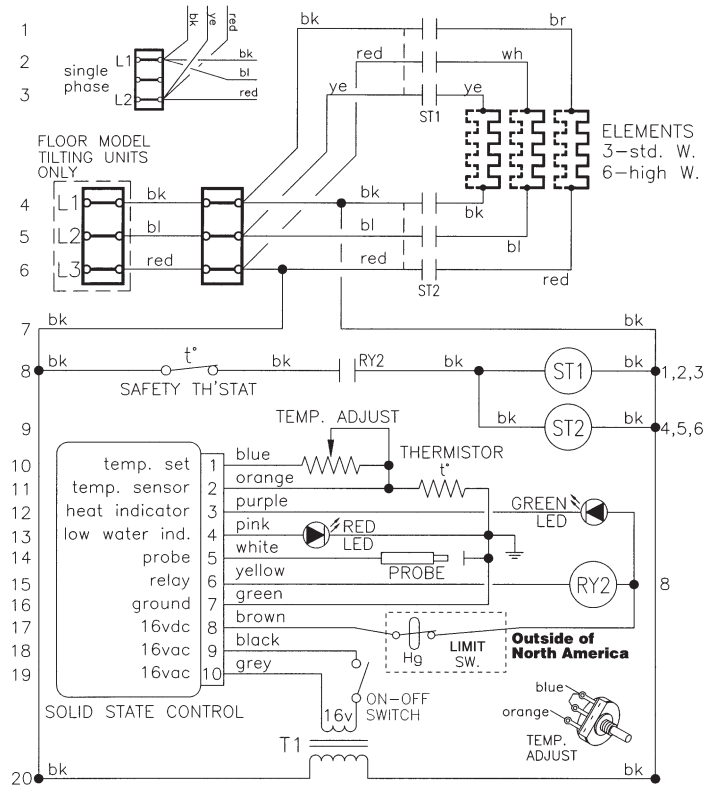

380-600v

