

DFW series deluxe food warmer owner's manual

Manufacturing Numbers:

9100101, 9100102, 9100103, 9100104,
9100105, 9100106, 9100107, 9100111,
9100112, 9100113, 9100114, 9100115,
9100116, 9100118, 9100121, 9100122,
9100123, 9100124, 9100125, 9100126,
9100128, 9100131, 9100132, 9100133,
9100134, 9100135, 9100136, 9100146,
9100147, 9100156

Table of Contents

General	2
Warranty Information.....	2
Service/Technical Assistance.....	2
Important Safety Information.....	3
Warnings	3
Specifications	4
Shipping Weight.....	4
Capacities.....	4
Installation	5
Plumbing	5
General information	6
Operating Instructions.....	6
Programming	7
Hi-Limit Reset Button.....	8
Fault Codes	8
Diagnostic LEDs.....	8
Daily Maintenance	8
Monthly Maintenance	9
Troubleshooting.....	11
Cooking Guide	14
Replacement Parts.....	15
Replacement Parts	
– DFW/DFWT-100/150.....	16
Replacement Parts	
– DFW/DFWT-200/250.....	18
Replacement Parts	
– DFWF-250 ONLY	20
Wiring Diagram	22
Limited Warranty.....	24

⚠ IMPORTANT ⚠

A.J. Antunes & Co. reserves the right to change specifications and product design without notice. Such revisions do not entitle the buyer to corresponding changes, improvements, additions or replacements for previously purchased equipment.

⚠ IMPORTANT ⚠

Keep these instructions for future reference. If the unit changes ownership, be sure this manual accompanies the equipment.

GENERAL

The Deluxe Food Warmer (steamer) produces a steam using plain tap water for quick heating and reconstituting of food items. Simple push-button action delivers a shot of water that is immediately converted into steam. Because the amount of steam is consistent, it removes the guesswork and produces a uniform finish from one operator to the next.

This manual provides the safety, installation, and operating procedures for the Deluxe Food Warmer (steamer). We recommend that all information contained in this manual be read prior to installing and operating the unit.

Your Deluxe Food Warmer (steamer) is manufactured from the finest materials available and is assembled to Roundup's strict quality standards. This unit has been tested at the factory to ensure dependable trouble-free operation.

WARRANTY INFORMATION

Please read the full text of the Limited Warranty in this manual.

If the unit arrives damaged, contact the carrier immediately and file a damage claim with them. Save all packing materials when filing a claim. Freight damage claims are the responsibility of the purchaser and are not covered under warranty.

The warranty does not extend to:

- Damages caused in shipment or damage as result of improper use.
- Installation of electrical service.
- Normal maintenance as outlined in this manual.
- Malfunction resulting from improper maintenance.
- Damage caused by abuse or careless handling.
- Damage from moisture into electrical components.
- Damage from tampering with, removal of, or changing any preset control or safety device.

SERVICE/TECHNICAL ASSISTANCE

If you experience any problems with the installation or operation of your unit, contact your local Roundup Authorized Service Agency.

Fill in the information below and have it handy when calling your Authorized Service Agency for assistance. The serial number is on the specification plate located on the rear of the unit.

Purchased From

Date of Purchase

Model Number

Serial Number

Manufacturing Number

Use only genuine Roundup replacement parts in this unit. Use of replacement parts other than those supplied by the manufacturer will void the warranty. Your Authorized Service Agency has been factory trained and has a complete supply of parts for this unit.

Visit www.ajantunes.com or contact the factory at 1-630-784-1000 to locate your nearest Authorized Service Agency.

Refer to the service agency directory packaged with your manual and fill in the information below.

Authorized Service Agency

Name

Phone Number

Address

IMPORTANT SAFETY INFORMATION

Use the following guidelines for safe operation of the unit.

- Read all instructions before using equipment.
- For your safety, the equipment is furnished with a properly grounded cord connector. Do not attempt to defeat the grounded connector.
- Install or locate the equipment only for its intended use as described in this manual. Do not use corrosive chemicals in this equipment.
- Do not operate this equipment if it has a damaged cord or plug, if it is not working properly, or if it has been damaged or dropped.
- This equipment should be serviced by qualified personnel only. Contact your nearest Authorized Service Agency for adjustment or repair.
- Do not block or cover any openings on the unit.
- Do not immerse cord or plug in water.
- Keep cord away from heated surfaces.
- Do not allow cord to hang over edge of table or counter.
- Turn the power off, unplug the power cord, and allow unit to cool down before performing any service or maintenance on the unit.
- The procedures in this manual may include the use of chemical products. These chemical products will be highlighted with bold face letters followed by the abbreviated HCS (Hazard Communication Standard). See Hazard Communication Standard manual for the appropriated Material Safety Data Sheets (MSDS).
- The equipment should be grounded according to local electrical codes to prevent the possibility of electrical shock. It requires a grounded receptacle with separate electrical lines, protected by fuses or circuit breaker of the proper rating.
- All electrical connections must be in accordance with local electrical codes and any other applicable codes.
- Do not clean this appliance with a water jet.

WARNINGS

Be advised of the following warnings when operating and performing maintenance on this unit.

- If the supply cord is damaged, it must be replaced by the manufacturer or its service agent or a similarly qualified person in order to avoid a hazard.
 - Do not modify the power supply cord plug. If it does not fit the outlet, have a proper outlet installed by a qualified electrician.
 - Do not use an extension cord with this appliance.
 - Electrical ground is required on this appliance.
 - Check with a qualified electrician if you are in doubt as to whether the appliance is properly grounded.
 - If a chemical cleaner is used, be sure it is safe to use on cast aluminum. Observe all precautions and warnings on product label.
 - Inspection, testing, and repair of electrical equipment should only be performed by qualified service personnel.
 - This equipment is to be installed to comply with the basic plumbing code of the Building Officials and Code Administrators, Inc. (BOCA) and the Food Service Sanitation Manual of the Food and Drug Administration (FDA).
 - On direct water hook-up units, water pressure must not exceed 30 psi (2.1 kg/cm² or 207 kPa). Higher water pressures will cause poor performance, excessive condensation, and flooding of the Steam Generator. To reduce water pressure, install a water pressure regulator and set water pressure to 20–30 psi (1.4–2.1 kg/cm² or 138–207 kPa). Contact your equipment supplier to purchase a Water Pressure Regulator.
 - To ensure proper steaming characteristics, some calcium/mineral deposits must be present on the generator surface. If, during cleaning, the surface does become free of calcium/mineral deposits, add plain tap water to the surface and allow it to boil off. This may have to be repeated several times to ensure proper steaming characteristics by creating a thin layer of deposits on the surface.
- Do not use a sanitizing solution or abrasive materials. The use of these may cause damage to the stainless steel finish.
 - Chlorides or phosphates in cleaning agents (e.g. bleach, sanitizers, degreasers or detergents) could cause permanent damage to stainless steel equipment. The damage is usually in the form of discoloration, dulling of metal surface finish, pits, voids, holes, or cracks. This damage is permanent and not covered by warranty.
 - The following tips are recommended for maintenance of your stainless steel equipment:
 - Always use soft, damp cloth for cleaning, rinse with clear water and wipe dry. When required, always rub in direction of metal polish lines.
 - Routine cleaning should be done daily with soap, ammonia detergent, and water.
 - Stains and spots should be sponged using a vinegar solution.
 - Finger marks and smears should be rubbed off using soap and water.
 - Hard water spots should be removed using a vinegar solution.

SPECIFICATIONS

Model & Mfg. No.	Volts	Watts	Amps	Hertz	Plug Description
DFW-100 9100101	120	1800	15	50/60	NEMA 5-15P 15 Amp, 120 Volt
DFW-100 9100102	120	1500	12.5	50/60	NEMA 5-15P 15 Amp, 120 Volt
DFW-100 9100103	230	2800	12.2	50/60	CEE 7/7 16 Amp. 250 Volt
DFW-150 9100104	120	1800	15	50/60	NEMA 5-15P 15 Amp, 120 Volt
DFW-150 9100105	120	1500	12.5	50/60	NEMA 5-15P 15 Amp, 120 Volt
DFW-150 9100106	230	2800	12.2	50/60	CEE 7/7 16 Amp. 250 Volt
DFW-150 9100107	230	2800	12.2	50/60	NEMA 5-15P 15 Amp, 120 Volt
DFW-200 9100111	120	1800	15	50/60	NEMA 5-15P 15 Amp, 120 Volt
DFW-200 9100112	120	1500	12.5	50/60	NEMA 5-15P 15 Amp, 120 Volt
DFW-200 9100113	230	2800	12.2	50/60	CEE 7/7 16 Amp. 250 Volt
DFW-250 9100114	120	1800	15	50/60	NEMA 5-15P 15 Amp, 120 Volt
DFW-250 9100115	120	1500	12.5	50/60	NEMA 5-15P 15 Amp, 120 Volt
DFW-250 9100116	230	2800	12.2	50/60	CEE 7/7 16 Amp. 250 Volt
DFW-200 9100118	230	2800	12.2	50/60	CEE 7/7 16 Amp. 250 Volt
DFWT-100 9100121	120	1800	15	50/60	NEMA 5-15P 15 Amp, 120 Volt
DFWT-100 9100122	120	1800	15	50/60	NEMA 5-20P 20 Amp. 120 Volt
DFWT-100 9100123	230	2800	12.2	50/60	CEE 7/7 16 Amp. 250 Volt
DFWT-150 9100124	120	1800	15	50/60	NEMA 5-15P 15 Amp, 120 Volt
DFWT-150 9100125	120	1800	15	50/60	NEMA 5-20P 20 Amp. 120 Volt
DFWT-150 9100126	230	2800	12.2	50/60	CEE 7/7 16 Amp. 250 Volt
DFWT-150 9100128	230	2800	12.2	50/60	IEC-309 16 Amp. 250 Volt
DFWT-200 9100131	120	1800	15	50/60	NEMA 5-15P 15 Amp, 120 Volt
DFWT-200 9100132	120	1800	15	50/60	NEMA 5-20P 20 Amp. 120 Volt
DFWT-200 9100133	230	2800	12.2	50/60	CEE 7/7 16 Amp. 250 Volt
DFWT-250 9100134	120	1800	15	50/60	NEMA 5-15P 15 Amp, 120 Volt
DFWT-250 9100135	120	1800	15	50/60	NEMA 5-20P 20 Amp. 120 Volt
DFWT-250 9100136	230	2800	12.2	50/60	CEE 7/7 16 Amp. 250 Volt
DFWF-250 9100146	208	3300	15.8	50/60	NEMA 6-20P 20 Amp. 250 Volt
DFWF-250 9100147	208	3300	15.8	50/60	NEMA 6-20P 20 Amp. 250 Volt
DFWF-250 9100156	230	3300	14.3	50/60	CEE 7/7 16 Amp. 250 Volt

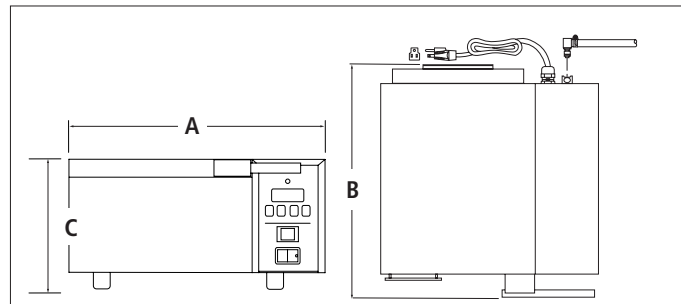

Model No.	Width (A)	Depth (B)	Height (C)
DFW-100 DFW-200 DFW-150 DFW-250	16 1/2" (419 mm)	17 1/4" (438 mm)	8 1/4" (209 mm)
DFWT-100 DFWT-200 DFWT-150 DFWT-250	20" (508 mm)	17 1/4" (438 mm)	8 1/4" (209 mm)
DFWF-250	26 7/8" (682 mm)	17 1/4" (438 mm)	9 7/16" (240 mm)

SHIPPING WEIGHT

DFW-100 Series	40 lbs (18.2 kg)
DFW-200 Series	40 lbs (18.2 kg)
DFWT-100 Series	54 lbs (24.5 kg)
DFWT-200 Series	54 lbs (24.5 kg)
DFWF-250 Series	75 lbs (33.6 kg)

CAPACITIES

DFW Series	2-7/8" (7.3 cm) Deep Half-size steam table pan
DFWT Series	2-7/8" (7.3 cm) Deep Two-third-size steam table pan
DFWF Series	4" (10.2 cm) Deep Full-size steam table pan

Model & Mfg. No.	Agency Approvals
DFW-100 DFW-150 DFW-200 DFW-250 DFWT-100 DFWT-150 DFWT-200 DFWT-250 DFWF-250	

INSTALLATION

NOTE: When placing the unit, make sure to provide at least 3 inches of space on all sides of the unit.

1. Remove unit and all packing materials from shipping carton.
2. The unit should come with the items listed below:
 - Owner's Manual
 - Authorized Service Agency Directory
 - Inlet Hose Assembly (DFW/DFWT/DFWF-200/250 only).

NOTE: If any parts are missing or damaged, contact Antunes Technical Service IMMEDIATELY at 1-877-392-7854 or 1-630-784-1000.

3. Remove all packing materials and protective coverings from the unit.
4. Remove and wash the Pan, Trivet, and Diffuser in soap and water. Rinse with clean water and allow to air dry.

NOTE: The steam generator surface (Figure 6) will have a white coating of artificial lime deposits. This coating is necessary for steaming characteristics.

5. Wipe all surfaces of the unit with a hot damp cloth.

NOTE: Do NOT use a dripping wet cloth. Wring out before use.

6. Re-install Pan, Trivet, and Pan Diffuser.

When placing the unit into service, pay attention to the following guidelines.

- Make sure to provide at least 3 inches of space on all sides of the unit.
- Make sure the power switch is off and the unit is at room temperature before plugging in the power cord.
- Do not block or cover any openings on the unit.
- Do not immerse the power cord or plug in water.
- Keep the power cord away from heated surfaces.
- Do not allow the power cord to hang over edge of table or counter.

Plug the power cord into the appropriate power outlet. Refer to the specification plate for the proper voltage.

1. With the power off, place the unit on a sturdy, level surface.
2. Ensure the line voltage corresponds to the stated voltage on the specification label and power cord warning tag.
3. Connect the unit to the power supply.

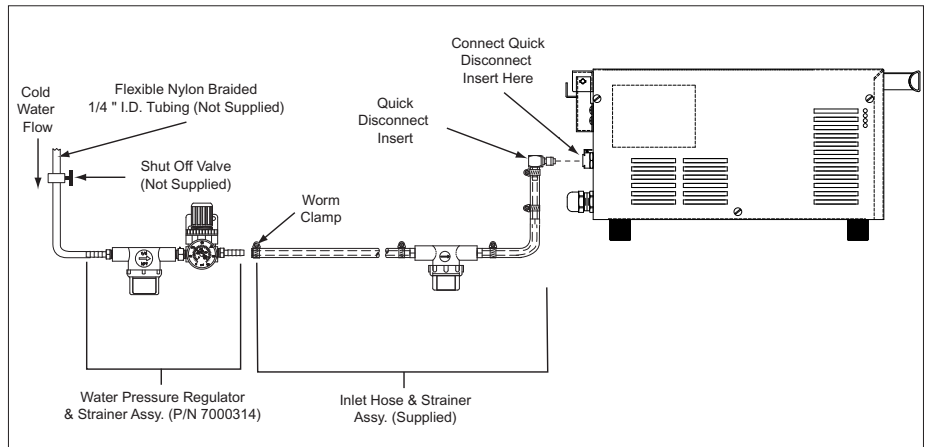

Figure 1. Connecting Water Supply to DFW/DFWT/DFWF-200/250

PLUMBING

DFW models are designed to use cold tap water. Distilled water may be used to reduce calcium/mineral deposit buildup and reduce maintenance costs.

MODELS DFW/DFWT-100/150

The DFW/DFWT-100/150 models have a self-contained water tank. To fill the tank:

1. Open the tank cover on the top of the unit.

NOTE: Make sure the filter inside the tank is installed properly.

2. Pour in cold tap water. The tank will hold approximately 3 quarts (2.81 liters). Do not overfill the tank.
3. Close the tank cover.

MODELS DFW/DFWT/DFWF-200/250

The DFW/DFWT/DFWF-200/250 models require a direct cold water hookup. A water inlet hose and strainer assembly (Figure 1) is supplied.

Incoming water is controlled by a normally closed solenoid valve located inside the steamer's electrical housing.

1. Turn off the water valve (not supplied) that provides water to the unit.
2. Connect the 1/4" (6.5 mm) ID flexible tubing to the outlet side of the water pressure regulator and secure using the worm clamp.

NOTE: A Water Pressure Regulator must be installed. Failure to do so will result in poor steaming and possible flooding. For a single steamer, use Water Pressure Regulator P/N 7000314. For two adjacent steamers, use Water Pressure Regulator P/N 7000235.

3. Turn the water valve on.
4. Over a bucket, press and hold the white plastic tip on the Quick Disconnect Insert (Figure 1) until a good, steady water flow is noted (this will purge all air out of the line).
5. Release and note the pressure on the water pressure regulator gauge. It should read 20-25 psi. Adjust the pressure by pulling the black knob upwards and turning it clockwise to increase or counter-clockwise to decrease the water pressure. Push the knob down to lock it in place.

NOTE: When adjusting the knob, you must relieve the existing pressure by pressing the plastic tip on the Quick Disconnect Insert for 3 seconds. This allows the newly set pressure to register on the gauge. Repeat this until the gauge reads 20-25 psi.

6. Push the Quick Disconnect Insert into the fitting at the rear of the unit until it clicks into place (Figure 1).

CAUTION

Water pressure must not exceed 30 psi (2.1 kg/cm² or 207 kPa). Higher water pressures may cause poor performance or flooding. To reduce water pressure, install a water pressure regulator, and set water pressure to 20-25 psi (1.4-1.7 kg/cm² or 138-172 kPa).

GENERAL INFORMATION

ALL MODELS

When the **OPERATE** button is pressed, power is supplied to the water pump (Water Tank models) or solenoid valve (Direct Water Hookup models). The pump/solenoid operates and water sprays onto the heated steam generator. The water flashes immediately into steam and steams the product.

TIMER MODELS DFW/DFWT/DFWF–150/250 EXCEPT DFWF-250 WITH MFG. NO. 9100147

On Timer Models, one of two operational modes can be used: Single Shot or Timed Cycle.

Single Shot

The **OPERATE** button is pressed and released to initiate a single steam shot. The Control Board applies power to the water pump/solenoid and a shot of steam occurs.

Timed Cycle

The control is used to set the desired steam time (up to 99 minutes, 59 seconds). When the **START/STOP** button (Figure 3) is pressed, the Control Board applies power to the water pump/solenoid at regular intervals for the duration of the displayed cycle time. The display counts down to zero, sounds an audible signal when the cycle is complete, and then reverts back to the original programmed cycle time. The unit is ready for the next cycle when the green ready light is on.

IMPORTANT: Timer Models are factory programmed for the following recommended settings:

- Total Cycle Time = [15.00] (15 minutes)
(Range: 3 sec. to 99 mins 59 secs)
- Shot Interval Time (SHO) = [00:20] (20 seconds)
(Range: 3 secs to 5 mins 59 secs). 20 seconds is recommended.
- Water Volume (H2O) =
DFW/DFWT/DFWF-250 - [0_50]
DFW/DFWT-150 - [0_80]
(Range: 0.10 seconds to 2.50)

The above settings convert approximately 3/4 oz. (25 milliliters) of water into to steam every 20 seconds for 15 minutes. To change any of these settings see the appropriate Operating Instructions for your specific unit.

⚠ WARNING ⚠

To avoid injury, be careful when opening top cover. Be sure to allow steam to escape before putting hands or face over the steamer.

OPERATING INSTRUCTIONS

NON-TIMER MODELS

1. Turn the power on (Figure 2).
2. Allow the unit to preheat for approximately 30 minutes.

NOTE: Do NOT push the OPERATE button during warm-up.

3. Open the top cover and place the product to be steamed onto the trivet, then close the cover.
4. Press the **OPERATE** button for 1 second then release and wait 20 seconds for the steam to penetrate the product. Repeat if product requires more steam.

NOTE: Pressing and holding the OPERATE button for longer than 1 second at a time, and/or too often (before 20 seconds), will flood out the Generator surface (Figure 6) and result in poor steaming.

5. Remove steamed product.

TIMER MODELS

1. Turn the power on (Figure 3).
2. Allow the unit to preheat for approximately 30 minutes.

IMPORTANT: The flashing green Ready Light will become steady when the unit is up to temperature and ready to be used.

IMPORTANT: Do NOT push the OPERATE button during warm-up. The flashing green Ready Light indicates unit is not up to temperature.

3. Open the top cover and place the product to be steamed onto the trivet, then close the cover.
4. Single Shot: Press the **OPERATE** button for 1 second then release and wait 20 seconds for the steam to penetrate the product.
Timed Cycle: Press the **START/STOP** button to begin the steaming cycle. Display will count down to zero.
5. Remove steamed product.

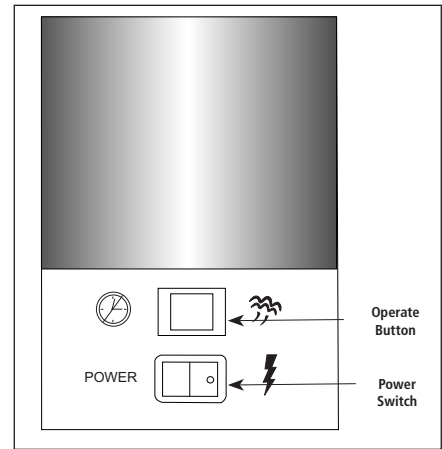

Figure 2. Control Panel (Non-Timer Models)

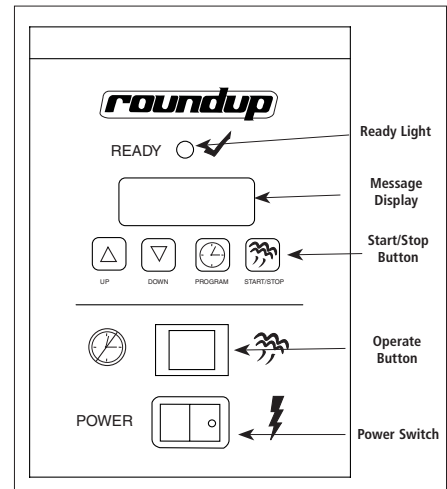

Figure 3. Control Panel (Timer Models)

PROGRAMMING

CYC (Total Cycle Time) refers to the total amount of steaming time set for the product.

SHO (Shot Interval Time) is the time set between shots of steam during a complete cycle.

H2O Setting (Steam Shot Time) is used to adjust the water volume used during each pump/solenoid operation.

The amount of steam produced by your Deluxe Food Warmer (steamer) depends on the amount of water sprayed onto the steam generator.

Flooding of the Generator may occur if the H2O setting is set too high. To prevent this from occurring, the Shot Interval Time (SHO) may be increased to allow more time for generator heat recovery. Adjustments should be made to both values to determine the optimum settings for your cooking needs.

To program the control, refer to Figure 4 and use the following procedure in sequence:

1. Turn the power on. The display shows the factory programmed Total Cycle Time in minutes and seconds (Item A, Figure 4).

2. Press and release the **PROGRAM** button to change the control from Operation to Program mode.
3. To change the Total Cycle Time in minutes, use the **UP** or **DOWN ARROW** buttons to change the time (Item B, Figure 4).
4. Press and release the **PROGRAM** button again and use the **UP** or **DOWN ARROW** buttons to change the Total Cycle Time in seconds (Item C, Figure 4).
5. To change the SHO factory settings, make sure the control is in Program mode, then press and hold the two **ARROW** buttons simultaneously for 1-2 seconds and then release. SHO will be displayed (Item D, Figure 4).
6. Press and release the **PROGRAM** button and use the **UP** or **DOWN ARROW** buttons to change the SHO setting in seconds (Item E, Figure 4).

NOTE: 20 seconds is recommended.

7. Press and release the **PROGRAM** button again and use the **UP** or **DOWN ARROW** buttons to change the SHO setting in minutes (Item F, Figure 4).

NOTE: 00 minutes is recommended.

8. Press and release the **PROGRAM** button again and "H2O" is displayed (Item G, Figure 4).
9. To change the H2O setting, press and release the **PROGRAM** button again to display the setting (Item H, Figure 4). Use the **UP** or **DOWN ARROW** buttons to increase or decrease the time.

NOTE: Recommended settings are :

- DFW/DFWT/DFWF-250 [0_50]
- DFW/DFWT-150 [0_08]

10. Press either the **START/STOP** or **OPERATE** button to store the changes and to exit the Program mode.

NOTE: The START/STOP or OPERATE button may be pressed at any time during programming to store the changes and exit the Program mode.

NOTE: If no change is made within 5 seconds at any time during the programming process, all changes made up to that point are stored in memory and the control reverts to the Operation mode.

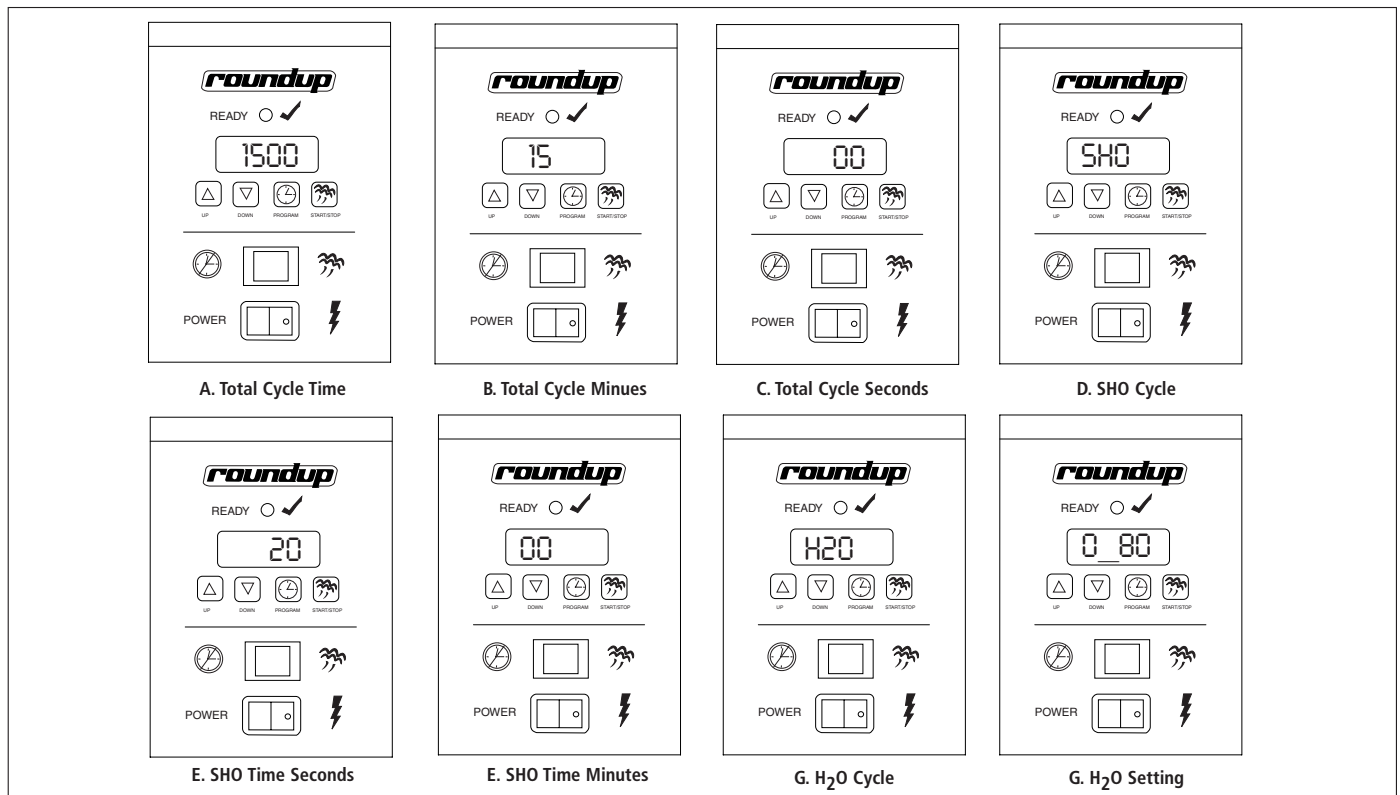

Figure 4. Control Programming Sequence

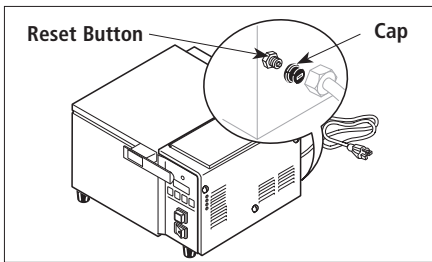

Figure 5. Hi-Limit Reset Button

HI-LIMIT RESET BUTTON

A hi-limit thermostat will turn off electrical power to the heater and control circuits if the unit overheats. To reset the thermostat, allow sufficient time (about 45 minutes) for the unit to cool down, remove the cap and press the red reset button located on the rear of the unit (Figure 5).

If the unit requires continuous resetting, contact your Authorized Service Agency.

FAULT CODES

When the programming parameters for Minutes, Seconds, SHO, or H2O have been inadvertently changed to a setting above or below their limits, the unit displays the "ERR" fault code. If this fault code appears, you must clear these settings using the following procedure.

1. Turn the power off.
2. Press and hold the **PROGRAM** and **START/STOP** buttons simultaneously.
3. Turn the unit on while holding the buttons. Release the buttons when the unit stops beeping.

NOTE: Repeat steps 1 through 3 if the unit still displays the "ERR" fault code.

4. The display will now register 15:00.

NOTE: It is recommended that the SHO and H2O settings be adjusted to the recommended settings shown in the Programming section of this manual.

DIAGNOSTIC LEDS

TIMER MODELS

This control board has 4 diagnostic LEDs described below.

Green (Program): When lit, indicates the unit is in Program mode.

Yellow (Audio): When lit, indicates 10-15 VDC is being supplied to the audio signal. The audio signal will sound and the LED will be lit for approximately 3 seconds.

Red (Heat): When lit, indicates the unit is calling for heat by supplying 10-15 VDC to the solid state relay. When off, indicates the generator surface is up to temperature.

Green (H2O): When lit, indicates that 24 VAC is being supplied to operate the solenoid valve used in DFW/DFWT/DFWF-250 units or to the water pump used in the DFW/DFWT-150 units.

NOTE: This LED is only lit for approximately 1 second.

NON-TIMER MODELS ONLY

This control board has 2 diagnostic LEDs described below.

Yellow (CR2): If lit, indicates the thermistor probe is disconnected or open. The thermistor should be 100k ohms +/- 2% at room temperature.

NOTE: The unit will not call for heat. This LED should NOT be lit during normal operation.

Red (CR4): When lit, indicates that the unit is calling for heat by supplying 15-20 VDC to the solid state relay. When off, indicates that the Generator surface is up to temperature.

⚠ CAUTION ⚠

Do not use a sanitizing solution or abrasive materials. The use of these may cause damage to the stainless steel finish.

⚠ CAUTION ⚠

If a chemical cleaner is used, be sure it is safe to use on cast aluminum. Observe all precautions and warnings on product label.

⚠ WARNING ⚠

Turn the power off, unplug the power cord, and all the unit to cool down before performing any service or maintenance.

⚠ WARNING ⚠

Be sure to follow all the precautions, procedures, and safety steps listed in the Important Safety Information section of this manual.

DAILY MAINTENANCE

NOTE: Frequency of cleaning is determined by water conditions, usage and water filter systems.

1. Turn the power off, unplug the power cord, and allow the unit to cool down before proceeding.
2. Check the water pressure regulator gauge (DFW/DFWT/DFWF-200/250 units only) and verify that it reads 20–25 psi (1.4–1.7 kg/cm² or 138–172 kPa). If not, adjust the water pressure as described in the Installation section of this manual. Check the rear water Quick Disconnect Fitting and Hose Clamp for leakage. Tighten clamps or replace parts if needed.
3. Remove the trivet and pan (Figure 6).
4. Wash items in hot, soapy water and then rinse and wipe dry.
5. Wipe down the top cover, gasket, and the entire exterior of the unit (Figure 6) with a clean, hot, damp cloth (not dripping wet) and wipe dry.
6. Re-install diffuser, pan and trivet.

NOTE: Allow top cover to remain open overnight.

NOTE: Failure to properly clean and dry the above mentioned items may result in the accumulation of water/moisture overnight. This may lead to permanent damage to the equipment's finish and its accessories. This damage is not covered by warranty.

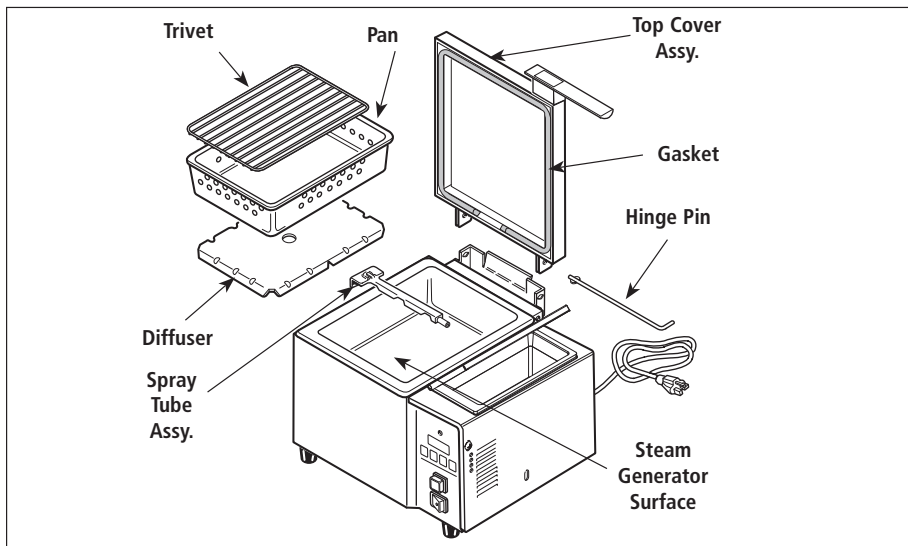

Figure 6. Deluxe Food Warmer Components (DFW-150 Shown)

MONTHLY MAINTENANCE

CLEAN SPRAY TUBE AND STEAM GENERATOR

The Deluxe Food Warmer utilizes an open Steam Generator. Water sprayed onto the generator surface flashes into steam immediately, but the minerals in the water do not steam. They stay on the generator surface. A small amount of calcium/mineral deposits are needed for proper operation, but a buildup of excessive calcium/mineral deposits causes poor steaming efficiency and excessive moisture (wet steam), which will eventually severely retard the steaming action.

1. Turn the power off, unplug the power cord, and allow the unit to cool down before proceeding.
2. Perform the Daily Cleaning, but do not reassemble the unit.
3. Remove the spray tube (Figure 6) by lifting the loose end and pulling it out of the generator hole.
4. Slide the metal cover off of the spray tube, take a paper clip and clear out all of the tube's holes.
5. Gently wash the tube under running water to clear the deposits out of the loose end. Reattach the cover onto the tube.

NOTE: Do not bend the spray tube. Any bends in the tube will result in permanent damage.

6. Use a scraper or spatula to remove the excessive calcium/mineral buildup from the generator surface (Figure 6).
7. Thoroughly wipe the generator with a damp cloth to remove any loose buildup and reassemble the unit.

NOTE: If deposits are still excessive and/or difficult to remove, refer to Steps 1 through 6 below.

1. Pour delimer solution (not supplied) onto the generator surface. Follow the delimer manufacturer's instructions for proper mixture and use.
2. Using a sponge or a dry towel, remove the delimer solution from the generator surface and then rinse the surface with clean water.

To ensure proper steaming characteristics, some calcium/mineral deposits must be present on the generator surface. If, during cleaning, the surface does become free of calcium/mineral deposits, add plain tap water to the surface and allow it to boil off. If necessary, repeat this process to formulate a thin coating of calcium/mineral deposits.

In soft water areas, it may be necessary to add a small amount of lime to the generator surface to season it. This will ensure proper steaming characteristics by producing a thin coating of calcium/mineral deposits on the Generator surface.

Seasoning mixture consists of 3/4 ounces (25 ml/25 cc) baking soda, 3/4 ounces (25 ml/25 cc) lime mixed with 1 quart (950 ml/950 cc) of water. Stir mixture and pour 1/4" deep onto the hot Generator surface. After mixture is converted to steam, the remaining loose powder can be removed.

3. Plug the power cord into the appropriate outlet.
4. Turn the power on and allow the unit to warm up for approximately 30 minutes.
5. Push and release the **OPERATE** button several times to purge any remaining delimer residue from the generator surface.
6. Turn the power off, reinstall all parts and accessories, and return the unit to service.

MONTHLY MAINTENANCE

WATER TANK FILTER (DFW/DFWT-100/150 ONLY)

The water tank filter is used to prevent particles or food products from entering and damaging the water pump. Inspect and clean this filter monthly or more regularly using the following procedure.

1. Turn the power off, unplug the power cord, and allow the unit to cool down before proceeding.
2. Open the slide door (Figure 7).
3. Remove the water tank filter, located inside the tank, by pulling it upwards and out of the bottom hole.
4. Clean the filter by running it under tap water. Replace the water tank filter if the screen is torn or damaged.
5. Reinstall the filter stem into the bottom hole of the tank (Figure 7).
6. Fill the water tank and test the unit.

WATER STRAINER (DIRECT WATER HOOKUP MODELS)

The water strainer protects your equipment from any foreign debris in the water line that could damage the unit's solenoid (causing the unit to leak/flood). To ensure proper and consistent steaming results, check the water pressure regulator and strainer cup regularly. If the pressure on the gauge has dropped, check the strainer cup and clean out the accumulated debris as follows:

1. Shut off the water supply valve to the unit, unscrew the strainer cup, and carefully remove the mesh strainer screen.
2. At the sink, gently flush all of the accumulated debris from the strainer cup and mesh strainer screen. Be especially careful not to damage the mesh strainer screen.
3. Carefully place the mesh strainer screen into its seat at the bottom of the strainer cup and confirm that the orange O-ring is properly seated in its place before screwing the strainer cup and top back together.
4. Purge the air out of the strainer and tubing by disconnecting the male quick disconnect insert from the equipment and, over a bucket, push the white plastic tip in until there is good water flow.
5. Replace damaged or worn parts.
6. Verify that the water pressure regulator is set to 20–25 psi (1.4–1.7 kg/cm² or 138–172 kPa).

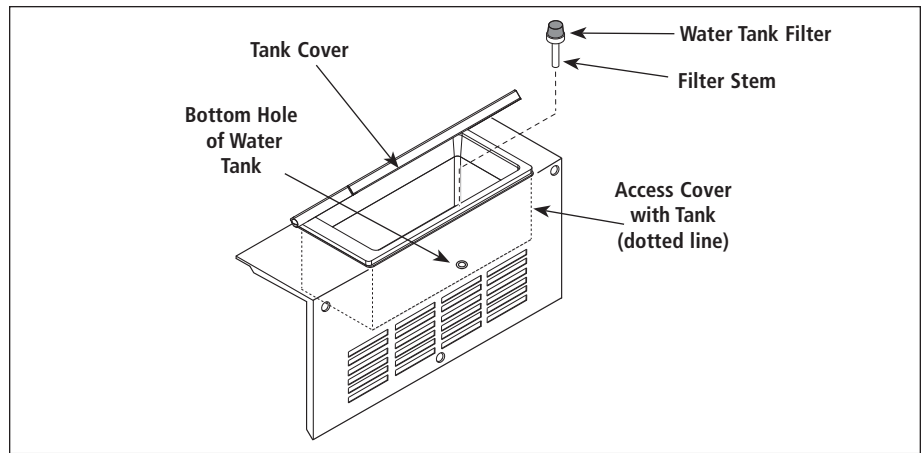
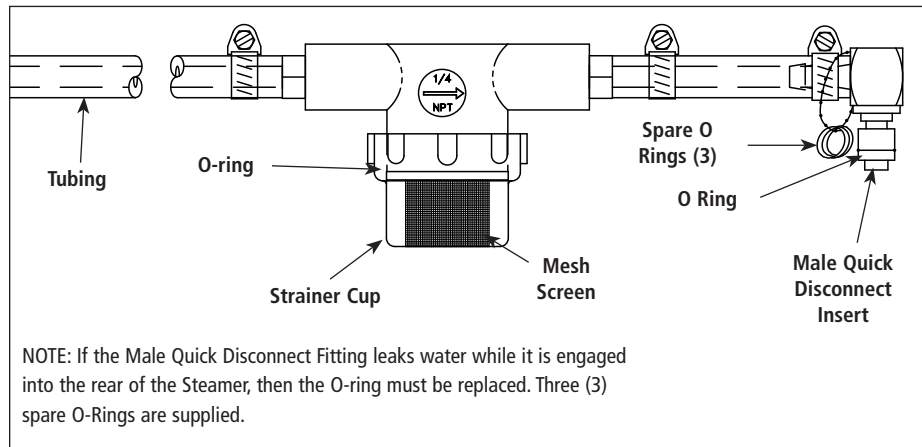

Figure 7. Water Tank Filter



NOTE: If the Male Quick Disconnect Fitting leaks water while it is engaged into the rear of the Steamer, then the O-ring must be replaced. Three (3) spare O-Rings are supplied.

Figure 8. Inlet Hose Assembly

TOP COVER ADJUSTMENT

It is normal for a small amount of steam to escape around the front and sides of the top cover. However, excessive steam may indicate the top cover gasket is worn and/or the cover is out of adjustment or damaged.

1. With the top cover closed, loosen the four rear hinge bracket screws (Figure 9) one turn only.
2. Push down on the top cover heavily (Figure 9). This ensures the gasket is seated squarely around the Generator. While maintaining the downward pressure, re-tighten the screws.

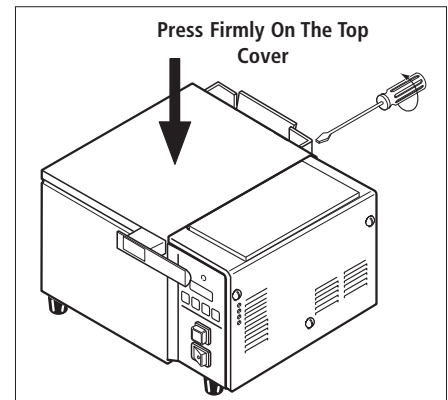

Figure 9. Top Cover Adjustment

TROUBLESHOOTING

⚠ WARNING ⚠

To avoid possible personal injury and/or damage to the unit, inspection, test, and repair of electrical equipment should be performed by qualified service personnel. The unit should be unplugged when servicing, except when electrical tests are required. Use extreme care during electrical circuit tests. Live circuits will be exposed. If the troubleshooting steps listed below do not solve your machine's problem, contact an Authorized Service Agency for further assistance.

Problem	Possible Cause	Corrective Action
Control Display is blank (Power is on but indicator light is off) Timer Models Only.	The power cord is not correctly plugged in.	Plug the power cord into the appropriate outlet.
	The power cord and/or electrical plug is damaged.	Inspect electrical wire, plug, and receptacle.
	The main electrical panel circuit breaker is off or has tripped.	Reset circuit breaker. Contact your maintenance person or Authorized Service Agency if it trips again.
	Power Switch is inoperable.	Contact your maintenance person or Authorized Service Agency for service.
Control Display is blank (Power is and indicator light is on). Timer Models Only	Control Board is inoperable.	Contact your maintenance person or Authorized Service Agency for service.
	Transformer is inoperable.	
	Loose, burnt, or broken wires in circuit.	
Unit does not heat up (Power is on and indicator light is on).	Hi-Limit Thermostat is tripped or inoperable.	Reset the Hi-Limit Thermostat according to the Operations section of this manual. If the Hi-Limit Thermostat requires continuous resetting, contact your Authorized Service Agency for service.
	Transformer is inoperable.	
	Solid State Relay is inoperable	
	Thermocouple is inoperable (Timer Models Only).	
	Control Board is inoperable.	
	Steam Generator is inoperable.	
	Loose, burnt, or broken wires in circuit.	
	Thermistor is inoperable (Non-Timer Models Only).	
The unit's main electrical panel circuit breakers trips.	Damaged receptacle, plug, or cord or a loose connection or an internal component failure.	Turn power off, allow unit to cool to room temperature, and then restart the unit. Contact your maintenance person or Authorized Service Agency if the condition repeats.
	Circuit breaker is overloaded.	
Water leaking inside electrical housing.	Pinhole leak in robber hoses (DFW/DFWT-100/150).	Replace hoses.
	Loose or damaged water line tubes and/or fittings inside electrical housing.	Tighten or replace tubes and/or fittings.
Water leaking at Male Quick Disconnect Fitting while it is engaged into steamer (DFW/DFWT/DFWF-200/250)	The O-ring on the Male Quick Disconnect is damaged.	Replace O-ring. Refer to the Maintenance section of this manual (Figure 8).
"ERR" appears on the Control Display (Timer Models only).	Programming and or SHO and H2O values were adjusted/changed improperly (Timer Models Only).	Reset the Control Board as described in the Programming section of this manual. See Fault Codes.

TROUBLESHOOTING (continued)

Problem	Possible Cause	Corrective Action
Unit heats but there is little or no steam produced and/or The product requires more steaming than usual.	Water Line Valve is closed (DFW/DFWT/DFWF-200/250).	Check that the Water Line Valve is open.
	Filter Strainer and/or Spray Tube is restricted.	Check and clean the Filter Strainer and Spray Tube as described in the Maintenance section of this manual.
	Quick Disconnect is not fully engaged at the rear of the unit or is damaged (DFW/DFWT/DFWF-200/250).	Remove and re-engage the Quick Disconnect firmly until it clicks into place. Replace if damaged.
	Low or no water pressure in the water line (DFW/DFWT/DFWF-200/250).	Remove the Quick Disconnect Insert from the rear of the unit. While holding over an empty cup, press the white plastic tip. Strong, steady water flow should be noted. If so, re-engage firmly into unit. If not present or pressure is low, contact your maintenance person or plumber.
	Improper water pressure to unit (DFW/DFWT/DFWF-200/250).	Verify that a Water Pressure Regulator is installed and set to 20–25 psi.
	Unit is not being cleaned properly (daily/monthly).	Clean the unit daily and monthly as described in the Maintenance section of this manual.
	Programming and/or SHO, H2O values were adjusted/changed improperly (Timer Models only).	Reprogram the SHO and H2O values as described in the Programming section of this manual.
	Insufficient or excessive calcium/mineral deposits on the Generator surface.	Verify that a thin layer of calcium/mineral deposits is present on the Generator surface. Refer to the Maintenance section of this manual.
	Generator surface is bare.	The Generator surface must have a thin coating of calcium/mineral deposits for proper steaming. Refer to the Maintenance section of this manual.
	The Water Pump's rubber hoses are pinched or kinked (DFW/DFWT-100/150).	Straighten and reposition the rubber hoses.
	Top Cover Gasket is worn and/or cover is out of adjustment.	If noticeable steam escapes around the Cover, replace the gasket and/or adjust the Cover according to the Maintenance section of this manual.
	Generator Diffuser is missing.	Install Generator Diffuser or replace if missing.
Excessive condensation in Food Compartment.	Generator surface temperature is too low.	Verify that the Generator surface temperature is 380°F–420°F (193°C–215°C).
	Water pressure is too high (DFW/DFWT/DFWF-200/250).	Verify that the Water Pressure Regulator is set to 20–25 psi. Adjust accordingly.
Excessive Steam escapes from front or sides of steamer.	Programming and or SHO and H2O values were adjusted improperly (Timer Models only).	Reprogram the SHO and H2O values as described in the Programming section of this manual.
	Worn or damaged Top Cover Gasket.	Replace Top Cover Gasket.
	Top Cover out of adjustment.	Adjust Top Cover according to the Maintenance section of this manual.

TROUBLESHOOTING (continued)

Problem	Possible Cause	Corrective Action
Steam Generator's surface becomes flooded (fills with excess water).	Insufficient pre-heat time.	Remove excess water from the Generator surface and allow the unit 30 minutes of pre-heat time.
	The Green Momentary Switch is pressed for longer than 1 second.	Follow the "one in twenty" rule. Refer to the Operation section of this manual.
	Water Pressure Regulator is not installed (DFW/DFWT/DFWF-200/250).	Verify that a Water Pressure Regulator is installed and set to 20–25 psi. Adjust accordingly.
	Water pressure is too high (DFW/DFWT/DFWF-200/250).	Verify that a Water Pressure Regulator is installed and set to 20–25 psi. Adjust accordingly.
	Programming and/or SHO and H2O values were adjusted or changed improperly (Timer Models only).	Reprogram the Control Board to the recommended settings. Refer to the Programming section of this manual.
	Solenoid Valve is leaking due to debris trapped inside the plunger (DFW/DFWT/DFWF-200/250).	Attempt to flush the debris out of the valve by rapidly operating the unit on a number of single shot cycles and then letting it rest. If the unit still leaks, disassemble the Solenoid Valve and clean out the plunger. Reassemble the unit and test again. If a leak is still present, replace the Solenoid Valve. Contact your maintenance person or Authorized Service Agency.
	The Water Pump and/or its Check Valves are clogged or damaged.	Verify that the filter is present in the water tank. Disassemble and clean pump. Replace Check valves if damaged.
	Improper Daily/Monthly cleaning.	Follow the Daily/Monthly cleaning procedures carefully.
	The Generator surface temperature is too low.	Verify that the Generator surface temperature is between 380°F–420°F (193°C–215° C).
	Insufficient or excessive calcium/mineral deposits on the Generator surface.	Verify that a thin layer of calcium/mineral deposits is present on the Generator surface. Refer to the Maintenance section of this manual.
	There is no pre-strainer or filter on the water line (DFW/DFWT/DFWF-200/250).	The unit was supplied with a strainer. If missing, install strainer.
	Solenoid Valve is installed incorrectly (DFW/DFWT/DFWF-200/250).	If the Solenoid Valve was replaced, verify that the "IN" and "OUT" labels on the valve correspond to the water flow.

COOKING GUIDE

Use the suggested cooking times below on noodles, rice, cereals, breads, meat, seafood, poultry, eggs, and vegetables, or experiment with your own products and steaming times. A little more or less steam could enhance the appearance and flavor.

Product	Minutes	Product	Minutes	Product	Minutes
NOODLES AND RICE		MEAT		VEGETABLES	
Macaroni, Small Elbow or Shell (2 qt. cooked, 1 pt. water, 2 oz. oil)	5	Bratwurst, 6 (4 oz. ea.)	10	Artichokes, 4 Whole (5 oz. ea.)	20-22
Egg Noodles (2 qt. cooked, 1 pt. water, 2 oz. oil)	6-7	Frankfurters, 10 (1.6 oz. ea.)	3	Asparagus, Spears (1 lb.)	11-14
Rice, Converted or Regular (1 lb. with 1 qt. hot water)	20	Frankfurters, 8 (2 oz. ea.)	4	Asparagus, Spears, Medium, Frozen (2½ lb.)	15-17
Rice, Brown (1 lb. with 1½ qt. water)	45	Frankfurters, 6 (2.7 oz. ea.)	5	Broccoli, Cuts (1 lb.)	12-14
Spaghetti (2 qt. cooked, 1 pt. water, 2 oz. oil)	5	Ham Steak, 4 Cooked, Frozen (4 oz. ea.)	4-5	Broccoli, Cuts, Frozen (1¼ lb.)	13-14
Spaetzle (2 qt. cooked, 1 pt. water, 2 oz. oil)	3-5	Hamburgers, 4 Cooked, Frozen (4 oz. ea.)	7	Broccoli, Spears (1 lb.)	15-20
CEREALS		Hamburgers, 4 Raw, Frozen (4 oz. ea.)	10-11	Broccoli, Spears, Frozen (2 lb.)	17-18
Farina, Quick (¾ cup dry cereal with 1 qt. hot water)	5	Ribs, 4 Cooked (5 oz. ea.)	10	Brussel Sprouts, Frozen (1¾ lb.)	13-14
Grits, Instant (1 lb. dry cereal with 1½ qt. hot water)	3	Sausage, 16 Link, Cooked (1 oz. ea.)	8-10	Cabbage, 6 3 in. Wedge (1 oz. ea.)	15
Grits, Quick (1 lb. dry cereal with 2 qt. hot water)	10	SEAFOOD		Carrots, Sliced (1 lb.)	12
Oatmeal (2 qt. cooked, 1 cup water optional)	6	Alaskan King Crab Legs (1 lb.)	4-5	Carrots, Whole Baby, Frozen (2 lb.)	15-20
BREADS		Clams, 6 (to open)	shot of steam	Cauliflower, Whole (1 lb.)	13-20
Bagels, 4 (3 oz. ea.)	3	Red Snapper, 4 (6 oz. ea. Fillets)	5-7	Cauliflower, Florettes, Frozen (2 lb.)	14-18
Cloverleaf Rolls, 6 (1 oz. ea.)	shot of steam wait 20-30 seconds	Rock Lobster Tails, 5 (8 oz. ea.)	8	Corn, Whole Kernel, Frozen (1¼ lb.)	4
Dinner Rolls, 6 (1 oz. ea.)	shot of steam wait 20-30 seconds	Rock Lobster Tails, 5 Frozen (8 oz. ea.)	16	Green Beans, Whole (1 lb.)	15-17
Hamburger Buns, 4 (2½ qt. ea.)	shot of steam wait 20-30 seconds	Rock Lobster Tails, 4 (10 oz. ea.)	10	Green Beans, Whole, Frozen (1½ lb.)	13-14
Hot Dog Buns, 5 (2 oz. ea.)	shot of steam wait 20-30 seconds	Rock Lobster Tails, 4 Frozen (10 oz. ea.)	20	Green Beans, Cut, Frozen (1¼ lb.)	10
Hard Rolls, 4 (1½ oz. ea.)	2	Sea Scallops (1 lb.)	5-8	Greens, Chopped, Frozen (1 lb.)	40-45
Hoagie Buns, 3 (2 oz. ea.)	2	Shrimp, Green Headless, 20 (1 oz. ea.)	6	Lima Beans, Frozen (1¼ lb.)	12-15
Italian Bread, 3 (2½ oz. ea.)	shot of steam wait 20-30 seconds	Shrimp, Peeled, Deveined (1 lb.)	5-6	Okra, Whole, Frozen (1 lb.)	10-15
Kaiser Rolls, 4 (2½ oz. ea.)	1 ½	Shrimp, Peeled, Deveined, Frozen (1 lb.)	8-9	Parsnips, Sliced (1 lb.)	8-10
Onion Buns, 4 (2 oz. ea.)	shot of steam wait 20-30 seconds	Turbot Steaks, 3 (8 oz. ea.)	5	Peas, Frozen (1½ lb.)	8
Tamale, 7 (3 oz. ea.)	5	POULTRY		Potatoes, 8 Whole (3 oz. ea.)	25
Tamale, 7 Frozen (3 oz. ea.)	10	Chicken, 4 Quarter, (10 oz. ea.)	23-25	Potatoes, Mashed (2 qt.)	8
Tortilla, Corn	shot of steam wait 20-30 seconds	Chicken, 2 Half (1½ lb. ea.)	25	Spinach, Chopped, Frozen (3 lbs.)	25
Tortilla, Flour	shot of steam wait 20-30 seconds	Chicken Supreme, 6 Frozen,	30	Squash, Acorn, 4 (8 oz. pcs.)	15-20
		Pillow Pack (4 oz. ea.)		Squash, Winter, Puree, Frozen (1½ lb.)	15-17
		Chicken or Turkey Roll (2 lb., 5/8 in. Cubes, IQF)	7	Squash, Zucchini, Sliced, Frozen (1¼ lb.)	10
		Rock Cornish Game Hens, 2 Whole (26 oz. ea.)	25		
		Rock Cornish Game Hens, 4 Half (13 oz. ea.)	15		
		EGGS			
		Soft Boiled, 8 (In Shell)	6		
		Hard Boiled, 8 (In Shell)	15		
		Poached, 8	3		
		Scrambled, 1 qt.	5		

REPLACEMENT PARTS

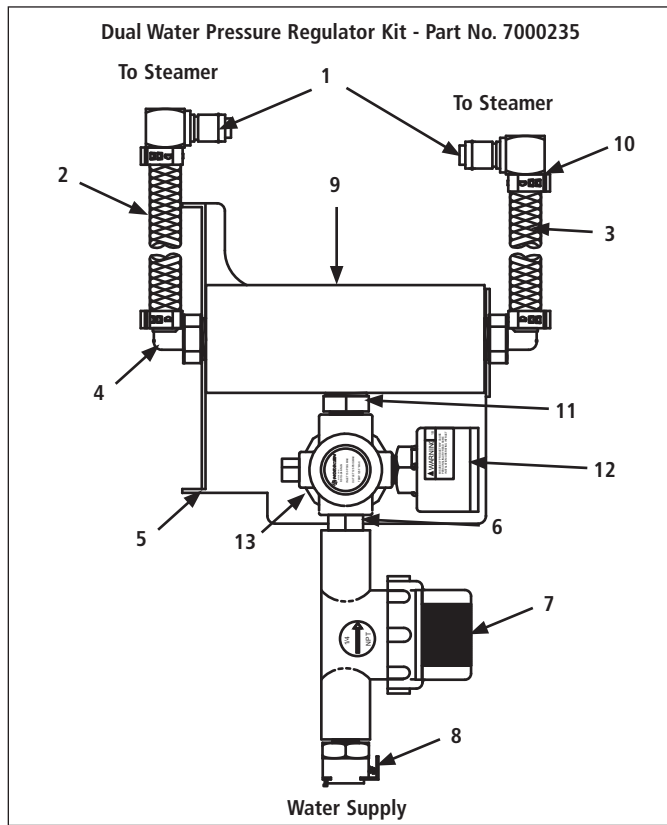

Item	Part No.	Description	Qty.
1	2080105	Elbow, Quick Disconnect - 1/4"	2
2	2030126	Tubing 1/4" I.D. PVC BRD. 24" Long	1
3	2030125	Tubing 1/4" I.D. PVC BRD. 12" Long	1
4	2040150	Elbow, Male - Nylon 1/4" Barb x 3/8" NPT	2
5	0503615	Bracket, Manifold Mtg.	1
6	2190129	Nipple 1/4" NPT x 1/4" NPT	1
7	2090127	Strainer - 1/4" FPT	1
8	2080118	Quick Disconnect - 1/8" NPT	1
9	2190113	Manifold	1
10	2110160	Clamp, Ear Med.	4
11	2040151	Nipple, HEx - 3/8" x 1/4" NPT Nylon	1
12	2170114	Gauge, Water Pressure	1
13	2170113	Regulator, Pressure	1

IMPORTANT: Two adjacent steamers can be fed with a Dual Water Pressure Regulator.

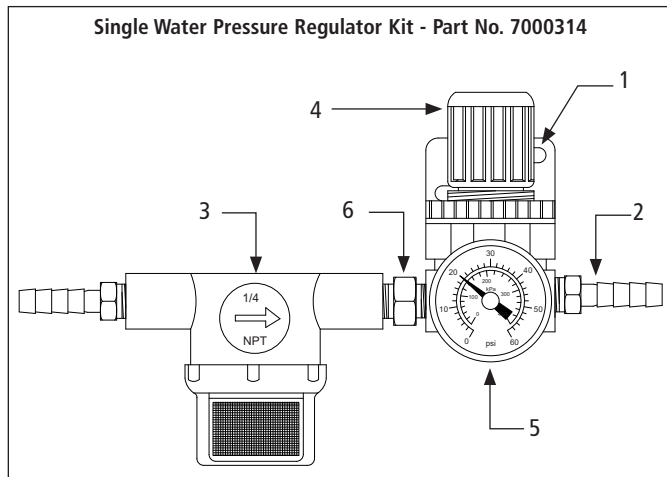

Item	Part No.	Description	Qty.
1	0503849	Bracket	1
2	2040130	Male Adapter, Barbed 1/4"	2
3	See Below for Strainer Parts Identification		
4	2170113	Regulator, Pressure	1
5	2170114	Gauge, Water Pressure	1
6	2190129	Nipple 1/4" NPT x 1/4" NPT	1
7	2110104	Clamp, Worm (not shown)	2

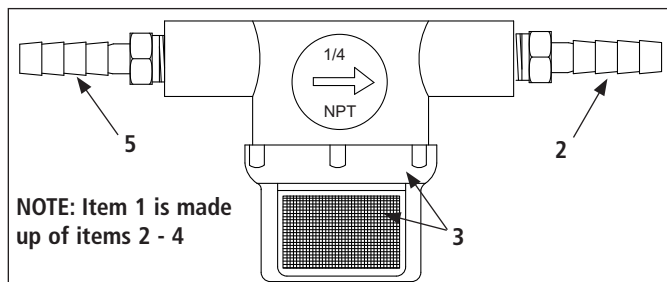

Item	Part No.	Description	Qty.
1	7000333	Water Line Strainer Kit	1
2	2040130	Male Adapter, Barbed 1/4"	2
3	7000334	Replacement Screen and O-ring Kit	1
4	2110104	Clamp, Worm (not shown)	2

REPLACEMENT PARTS – DFW/DFWT-100/150

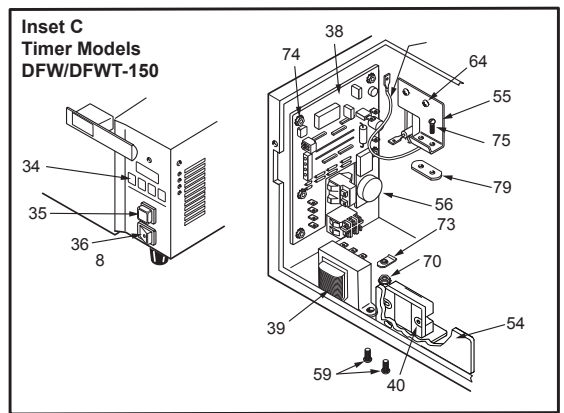
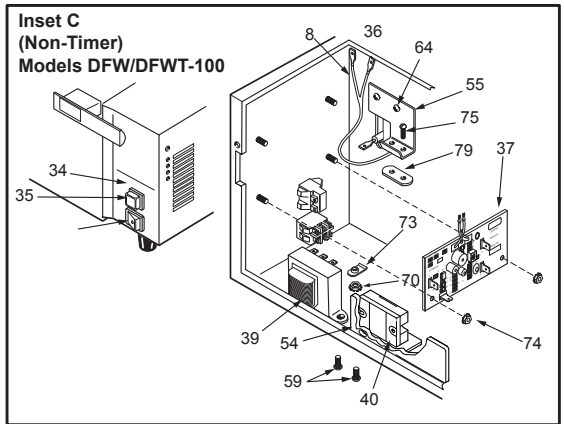
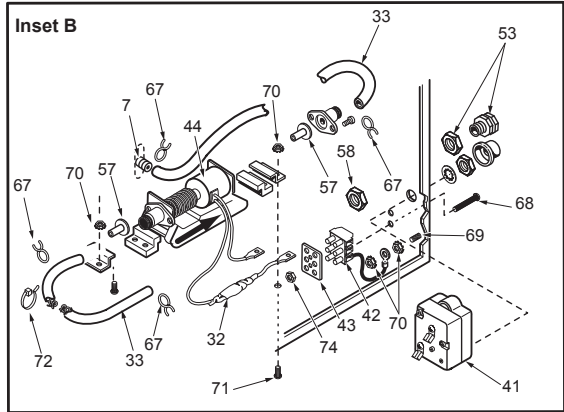
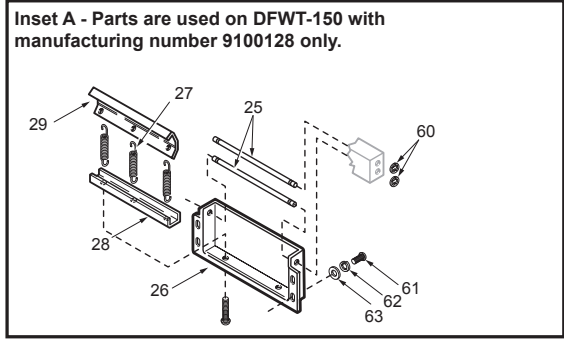
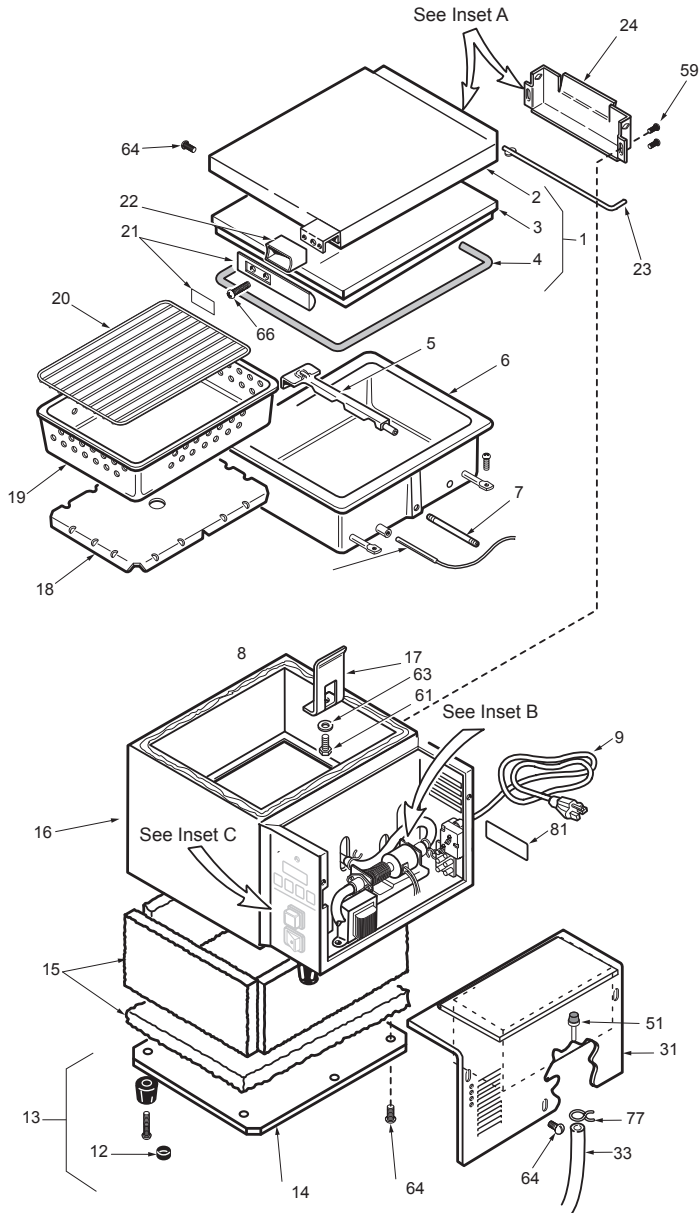

REPLACEMENT PARTS – DFW/DFWT-100/150 (continued)

Item	Part No.	Description	Qty.
1	0011115	Top Cover Assy. (DFW) (Incl. Nos. 2, 3 & 4)	1
	0011154	Top Cover Assy. (DFWT) (Incl. Nos. 2, 3 & 4)	1
	0011162	Top Cover Assy. (Mfg. # 9100128 only) (Incl. Nos. 2, 3 & 4)	1
2	0020578	Shelf, Top Cover (DFW)	1
	0020577	Shelf, Top Cover (DFWT)	1
	0020453	Shelf, Top Cover (Mfg. # 9100128 only)	1
3	0021065	Liner, Top Cover (DFW)	1
	0021090	Liner, Top Cover (DFWT)	1
4	7000122	Gasket, Top Cover (DFW)	1
	7000123	Gasket, Top Cover (DFWT)	1
5	0010145	Spray Tube Assy. (DFW)	1
	0010146	Spray Tube Assy. (DFWT)	1
6	7000124	Steam Generator, 120V (DFW Series) 1800 Watts	1
	7000147	Steam Generator, 120V (Mfg. # 9100102, 105)	1
	7000125	Steam Generator, 230V (DFW Series) 2800 Watts	1
	7000126	Steam Generator, 120V (DFWT Series) 1800 Watts	1
	7000127	Steam Generator, 230V (DFWT Series) 2800 Watts	1
7	7000448	Tube, Generator, 1/8" x 2-1/2" (DFW/DFWT-100 Series)	1
8	4050210	Thermistor (Non-Timer Models only)	1
	4050209	Thermocouple (Timer Models only)	1
9	0700451	Power Cord, 120 VAC, 14/3 5-20P	1
	0700463	Power Cord, 120 VAC, 14/3 5-15P	1
	0700453	Power Cord, 230 VAC, CEE 7/7	1
	0700437	Power Cord, 230 VAC, IEC-309	1
10	7000139	Quick Disconnect, Male	1
12	218P145	Cover, Leg	1
13	210K230	Leg, 1" (Pack of 4)	1
14	0503069	Base Plate (DFW Series)	1
	0503178	Base Plate (DFWT Series)	1
15	7000131	Insulation Kit (DFW)	1
	7000132	Insulation Kit (DFWT)	1

Item	Part No.	Description	Qty.
16	0021055	Main Housing (DFW)	1
	0021072	Main Housing (DFWT)	1
	0021092	Main Housing (Mfg. #9100128)	1
17	0503174	Retainer, Generator	2
18	0503177	Diffuser Pan (DFW)	1
	0503182	Diffuser Pan (DFWT)	1
19	2130102	Perforated Pan (DFW)	1
	2130103	Perforated Pan (DFWT)	1
20	0800106	Trivet (DFW)	1
	0800109	Trivet (DFWT)	1
21	7000133	Handle Kit (Incl. Nos. 22 & 66)	1
22	0020964	Cover, Handle Bracket	1
23	0800219	Hinge Pin, Top Cover	1
24	0501569	Hinge Base, Top Cover	1
25	0800280	Hinge Pin (Mfg. #9100128 only)	1
26	0502719	Hinge Base (Mfg. # 9100128 only)	1
27	0600125	Spring (Mfg. # 9100128 only)	3
28	0020952	Hinge Beam (Mfg. # 9100128 only)	1
29	0502722	Pivot Bracket (Mfg. # 9100128 only)	1
31	0012546	Access Cover Assy.	1
32	7000214	Diode Assy.	1
33	7000849	Silicone Tube Kit (Includes 2 tubes)	1
34	1000976	Label, Front Panel (Non-Timer Models only)	1
	1001036	Label, Front Panel (Timer Models only)	1
35	4010166	Operate Switch	1
36	4010151	Rocker Switch, 120V	1
	4010137	Rocker Switch, 230V	1
37	7000392	Control Board (Non-Timer Models only)	1
38	7000317	Control Board (Timer Models only)	1
39	7000319	Transformer	1
40	7000652	Relay, Solid State	1
41	7000135	Hi-Limit Thermostat	1
42	7000136	Terminal Block Kit (Incl. No. 43)	1
43	100P967*	Marking Label	1
44	7000137	Water Pump Kit, 24 VAC (Incl. No. 32 & 33)	1

Item	Part No.	Description	Qty.
45	7000142	Outlet Tube Kit (Incl. Nos. 46, 47 & 48)	1
46	204P114*	Elbow, Female, 1/4" Tube	1
47	2000188	Outlet Tube	1
48	2040103	Connector, Male, 1/4" Tube	1
49	4040145	Solenoid, 24V	1
50	7000138	Quick Disconnect Body & Plate Kit	1
51	0010159	Filter Assy., Water Tank	1
52	0010584	Inlet Hose Assy. with Strainer	1
53	040K251	Strain Relief	1
54	0505699	Relay Heat Sink	1
55	0503333	Bracket, Temperature Sensor	1
56	7000156	Audio Alarm Kit	1
57	7000170	Check Valve Kit, Discharge & Intake	1
58	040P138*	Locknut, Conduit, 1/2"	1
59	308P104*	Screw, #8-32 x 3/8", SS	1
60	211P127*	Retaining Ring	1
61	325P109*	Screw, Hex	1
62	325P154*	Lockwasher	1
63	325P104*	Washer, Flat	1
64	308P103*	Screw, #8-32 x 1/4", SS	1
65	308P164*	Screw, #8-32 x 1", SS	1
66	308P132*	Screw, #8-32 x 3/4", Flat, SS	1
67	211P195*	Hose Clamp	1
68	306P123*	Screw, #6-32 x 7/8", SS	1
69	308P124*	Screw, #8-32 x 1/2", 1-Way, SS	1
70	308P143*	Nut, Hex, #8-32 KEPS	1
71	308P108*	Screw, #8-32 x 3/4", SS	1
72	406P107*	Cable Tie	1
73	300P102*	Nut, Tinnerman, U-type	1
74	306P130*	Nut, Hex, #6-32 KEPS	1
75	306P103*	Screw, #6-32 x 3/8", SS	1
76	020P117*	O-Ring	1
77	211P101*	Hose Clamp, 3/8" Dia.	1
78	306P104*	Screw, #6-32 x 1/4", SS	1
79	301P106*	Nut, Spotweld, #6-32	1
80	304P105*	Nut, Hex, #4-40 KEPS	1
81	1000275	Label, Water & Waste Connection	1

* Only available in packages of 10.

REPLACEMENT PARTS – DFW/DFWT-200/250

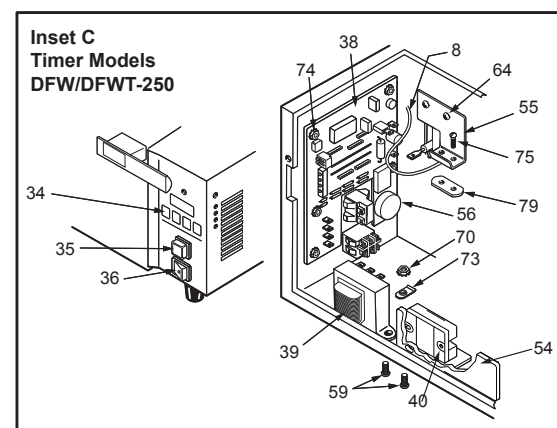
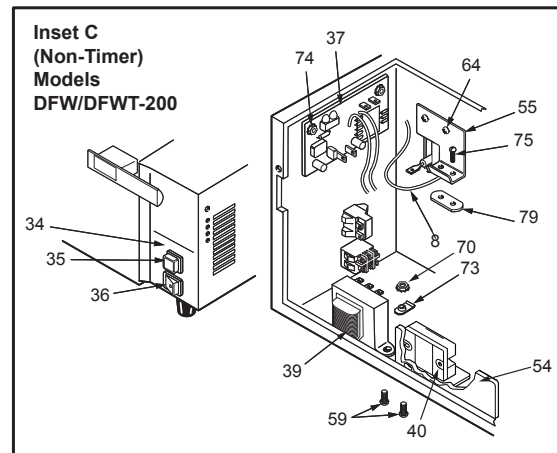
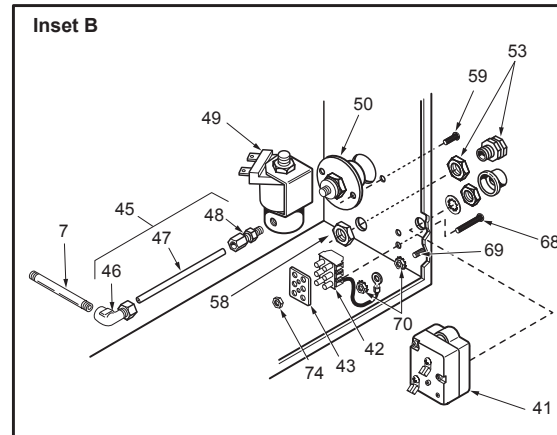
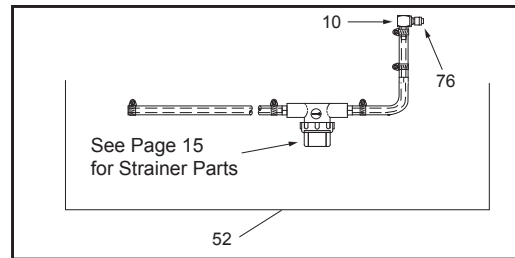
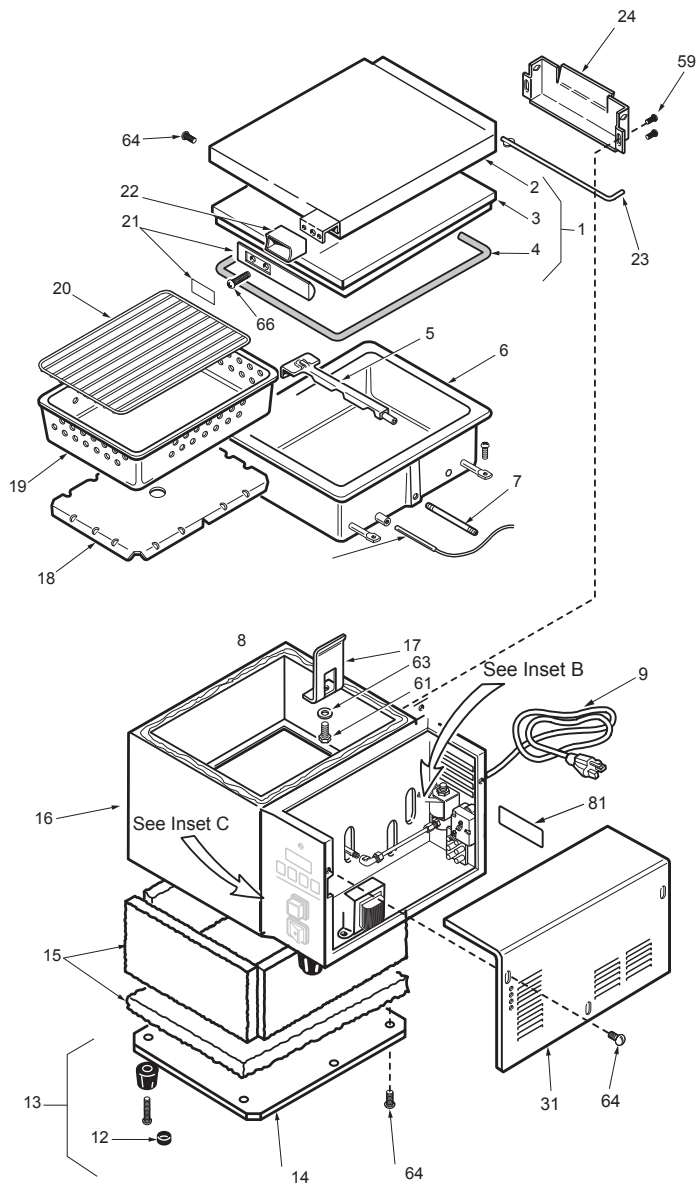

REPLACEMENT PARTS – DFW/DFWT-200/250 (continued)

Item	Part No.	Description	Qty.
1	0011115	Top Cover Assy. (DFW) (Incl. Nos. 2, 3 & 4)	1
	0011154	Top Cover Assy. (DFWT) (Incl. Nos. 2, 3 & 4)	1
2	0020578	Shelf, Top Cover (DFW)	1
	0020577	Shelf, Top Cover (DFWT)	1
3	0021065	Liner, Top Cover (DFW)	1
	0021090	Liner, Top Cover (DFWT)	1
4	7000122	Gasket, Top Cover (DFW)	1
	7000123	Gasket, Top Cover (DFWT)	1
5	0010145	Spray Tube Assy. (DFW)	1
	0010146	Spray Tube Assy. (DFWT)	1
6	7000124	Steam Generator, 120V (DFW Series) 1800 Watts	1
	7000147	Steam Generator, 120V (Mfg. # 9100112, 115)	1
	7000125	Steam Generator, 230V (DFW Series) 2800 Watts	1
	7000126	Steam Generator, 120V (DFWT Series) 1800 Watts	1
	7000127	Steam Generator, 230V (DFWT Series) 2800 Watts	1
7	7000447	Tube, Generator, 3-1/4" Lg.	1
8	4050210	Thermistor (Non-Timer Models only)	1
	4050209	Thermocouple (Timer Models only)	1
9	0700451	Power Cord, 120 VAC, 14/3 5-20P	1
	0700463	Power Cord, 120 VAC, 14/3 5-15P	1
	0700453	Power Cord, 230 VAC, CEE 7/7	1
	0700437	Power Cord, 230 VAC, IEC-309	1
10	7000139	Quick Disconnect, Male	1
12	218P145	Cover, Leg	1
13	210K230	Leg, 1" (Pack of 4)	1
14	0503069	Base Plate (DFW Series)	1
	0503178	Base Plate (DFWT Series)	1
15	7000131	Insulation Kit (DFW)	1
	7000132	Insulation Kit (DFWT)	1

Item	Part No.	Description	Qty.
16	0021055	Main Housing (DFW)	1
	0021072	Main Housing (DFWT)	1
17	0503174	Retainer, Generator	2
18	0503177	Diffuser Pan (DFW)	1
	0503182	Diffuser Pan (DFWT)	1
19	2130102	Perforated Pan (DFW)	1
	2130103	Perforated Pan (DFWT)	1
20	0800106	Trivet (DFW)	1
	0800109	Trivet (DFWT)	1
21	7000133	Handle Kit (Incl. Nos. 22 & 66)	1
22	0020964	Cover, Handle Bracket	1
23	0800219	Hinge Pin, Top Cover	1
24	0501569	Hinge Base, Top Cover	1
31	0505726	Access Cover Assy.	1
32	7000214	Diode Assy.	1
33	7000849	Silicone Tube Kit (Includes 2 tubes)	1
34	1000976	Label, Front Panel (Non-Timer Models only)	1
	1001036	Label, Front Panel (Timer Models only)	1
35	4010166	Operate Switch	1
36	4010151	Rocker Switch, 120V	1
	4010137	Rocker Switch, 230V	1
37	7000392	Control Board (Non-Timer Models only)	1
38	7000317	Control Board (Timer Models only)	1
39	7000319	Transformer	1
40	7000652	Relay, Solid State	1
41	7000135	Hi-Limit Thermostat	1
42	7000136	Terminal Block Kit (Incl. No. 43)	1
43	100P967*	Marking Label	1
44	7000137	Water Pump Kit, 24 VAC (Incl. No. 32 & 33)	1
45	7000142	Outlet Tube Kit (Incl. Nos. 46, 47 & 48)	1
46	204P114*	Elbow, Female, 1/4" Tube	1
47	2000188	Outlet Tube	1
48	2040103	Connector, Male, 1/4" Tube	1

Item	Part No.	Description	Qty.
49	4040145	Solenoid, 24V	1
50	7000138	Quick Disconnect Body & Plate Kit	1
51	0010159	Filter Assy., Water Tank	1
52	0010584	Inlet Hose Assy. with Strainer	1
53	040K251	Strain Relief	1
54	0505699	Relay Heat Sink	1
55	0503333	Bracket, Temperature Sensor	1
56	7000156	Audio Alarm Kit	1
57	7000170	Check Valve Kit, Discharge & Intake	1
58	040P138*	Locknut, Conduit, 1/2"	1
59	308P104*	Screw, #8-32 x 3/8", SS	1
60	211P127*	Retaining Ring	1
61	325P109*	Screw, Hex	1
62	325P154*	Lockwasher	1
63	325P104*	Washer, Flat	1
64	308P103*	Screw, #8-32 x 1/4", SS	1
65	308P164*	Screw, #8-32 x 1", SS	1
66	308P132*	Screw, #8-32 x 3/4", Flat, SS	1
67	211P103*	Hose Clamp, 1/2" Dia.	1
68	306P123*	Screw, #6-32 x 7/8", SS	1
69	308P124*	Screw, #8-32 x 1/2", 1-Way, SS	1
70	308P143*	Nut, Hex, #8-32 KEPS	1
71	308P108*	Screw, #8-32 x 3/4", SS	1
72	406P107*	Cable Tie	1
73	300P102*	Nut, Tinnerman, U-type	1
74	306P130*	Nut, Hex, #6-32 KEPS	1
75	306P103*	Screw, #6-32 x 3/8", SS	1
76	020P117*	O-Ring	1
77	211P101*	Hose Clamp, 3/8" Dia.	1
78	306P104*	Screw, #6-32 x 1/4", SS	1
79	301P106*	Nut, Spotweld, #6-32	1
80	304P105*	Nut, Hex, #4-40 KEPS	1
81	1000275	Label, Water & Waste Connection	1

* Only available in packages of 10.

REPLACEMENT PARTS – DFWF-250 ONLY

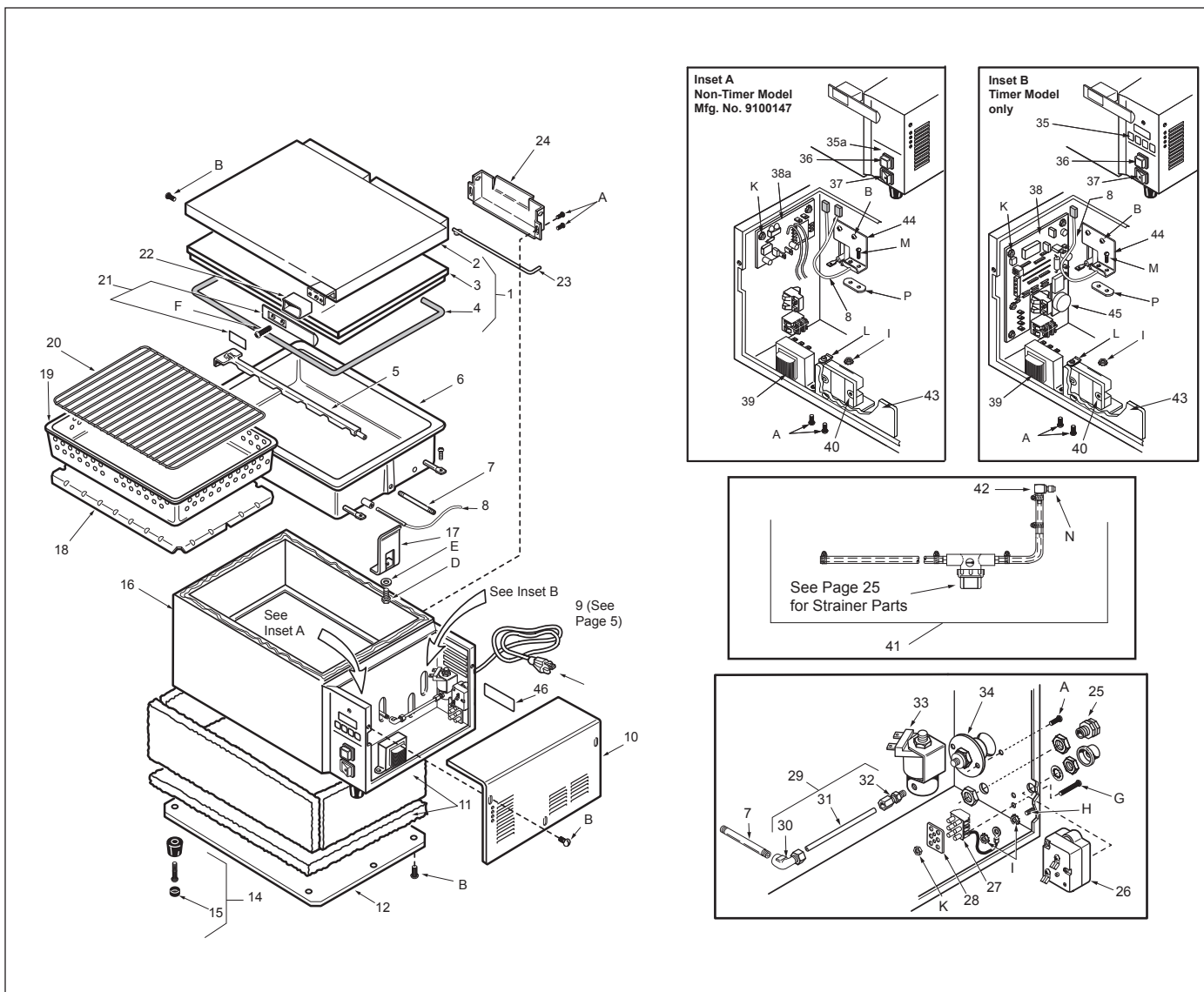

REPLACEMENT PARTS – DFWF-250 ONLY (continued)

Item	Part No.	Description	Qty.
1	0011165	Top Cover Assy. (Incl. Items 2, 3, & 4)	1
2	0020769	Top Cover Shell	1
3	0021094	Top Cover Liner	1
4	7000140	Top Cover Gasket Kit	1
5	0010147	Spray Tube Assy.	1
6	7000220	Generator, 230 VAC	1
	7000221	Generator, 208 VAC	1
7	7000447	Steam Generator Tube	1
8	4050209	Thermocouple (Timer Models Only)	1
8a	4050210	Probe Thermistor (Non-Timer Models) (Mfg. No. 9100417)	1
9	0700452	Power Cord (6-20P)	1
	0700453	Power Cord (CEE 7/7)	1
10	0503102	Access Cover	1
11	7000141	Insulation Kit	1
12	0503103	Base Plate	1
14	210K230	Leg, 1" (Pack of 4)	1
15	218P145*	Cover, Leg	1
16	0021095	Main Housing	1
17	0503186	Generator Retainer	2
18	0503187	Diffuser Pan	1
19	2130171	Pan, Full Size	1
20	0800113	Trivet	1
21	7000133	Handle Kit (Incl. #22)	1
22	0020964	Handle Bracket Cover	1

Item	Part No.	Description	Qty.
23	0800219	Top Cover Hinge Pin	2
24	0501569	Cover Hinge Base	2
25	040K251	Strain Relief	1
26	7000135	Hi-Limit Thermostat	1
27	7000136	Terminal Block Kit (Incl. Item 28)	1
28	100P967*	Marking Label	1
29	7000142	Outlet Tube Kit (Incl. #30, 31, & 32)	1
30	204P114*	Female Elbow 1/4"	1
31	2000188	Outlet Tube	1
32	2040103	Male Connector, 1/4"	1
33	4040145	Solenoid 24 VAC	1
34	7000138	Quick Disconnect Body & Plate Kit	1
35	1001036	Front Panel Label (Timer Models Only)	1
35a	1000976	Front Panel Label (Non-Timer Models) (Mfg. No. 9100147)	1
36	4010166	Operate Switch	1
37	4010137	Power Switch	1
38	7000317	Control Board (Timer Models Only)	1
38a	7000392	Control Board (Non-Timer Models) (Mfg. No. 9100147)	1
39	7000319	Transformer	1
40	7000652	Solid State Relay	1

Item	Part No.	Description	Qty.
41	0010584	Inlet House Assy. with Strainer	1
42	7000139	Quick Disconnect Kit	1
43	0505699	Heat Sink	1
44	0503333	Temp. Sensor Bracket	1
45	7000156	Audio Alarm Kit	1
46	4050210	Probe, Thermistor (Mfg. No. 9100147)	1
A	308P104*	Screw, #8-32 x 3/8"	1
B	308P103*	Screw, #8-32 x 1/4"	1
C	308P164*	Screw, #8-32 x 1"	1
D	325P109*	Hex Screw, #1/4" x 20 x 1/2"	1
E	325P104*	Flat Washer	1
F	308P132*	#8-32 x 3/4" Flat	1
G	306P123*	Screw, #6-32 x 7/8"	1
H	308P124*	Screw, #8-32 x 1/2"	1
		1 Way	1
I	308P143*	Hex Nut, #8-32, "KEPS"	1
J	306P101*	Hex Nut, #6-32 - SS	1
K	306P130*	Hex Nut, #6-32 "KEPS"	1
L	300P102*	"U" Type Tinnerman	1
M	306P103*	Screw, #6-32 x 3/8"	1
N	020P117*	Quick Disconnect O-Ring	1
O	306P104*	Screw, #6-32 x 1/4"	1
P	301P106*	Spotweld Nut, #6-32	1

* Items are available only in packages of ten (10) each.

WIRING DIAGRAM

DFW/DFWT/DFWF-150/250 Only
 Timer Models Only - Except DFWF-250 units with Mfg. No. 9100147

WIRING DIAGRAM

NOTE: ALL WIRES TO BE 14 GA. AWM-105°C
 UNLESS OTHERWISE SPECIFIED.

- # 18 GA. AWM-105°C
- 22 GA. AWM-105°C

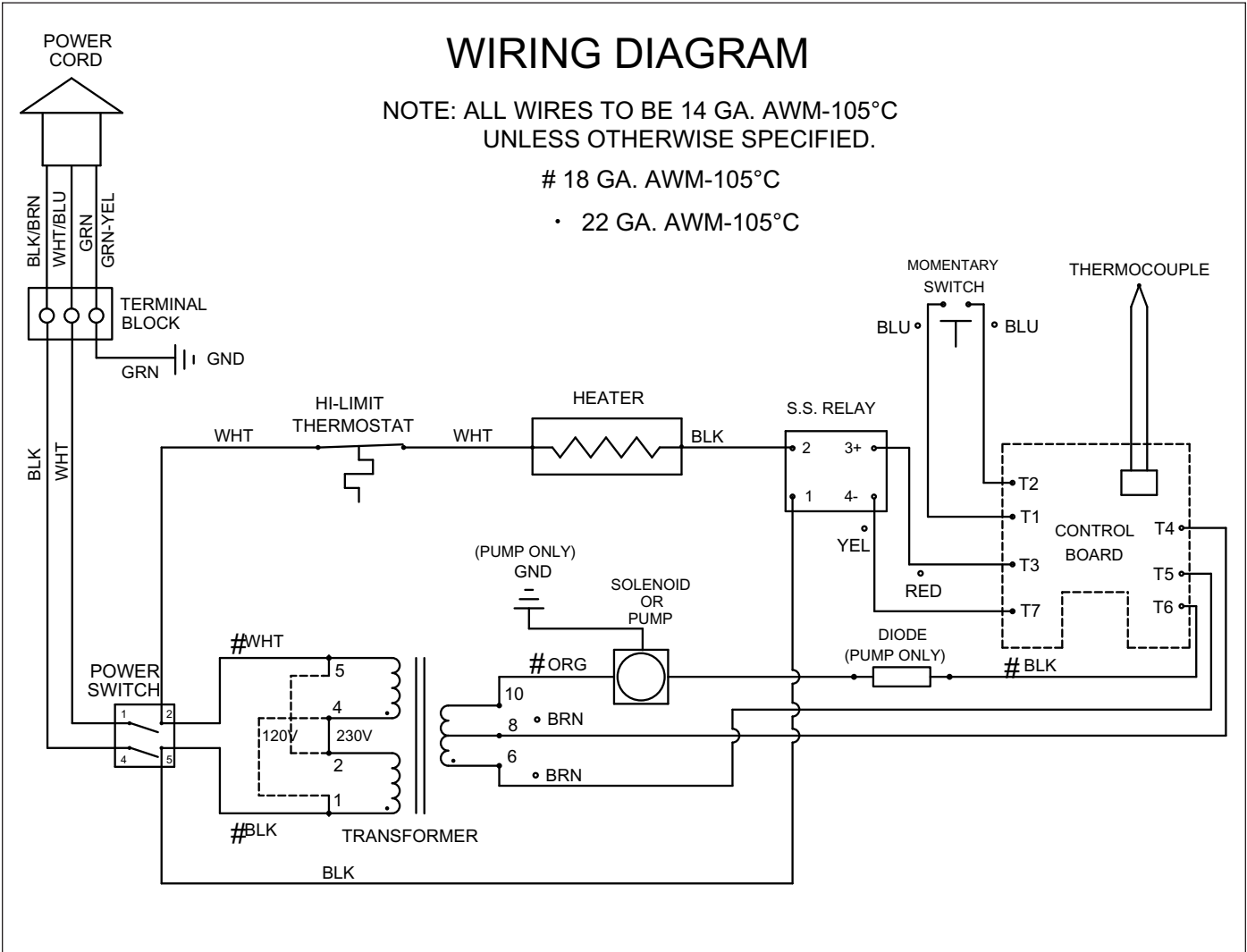

WIRING DIAGRAM (continued)

DFW/DFWT-100/200 and DFWF-250 Models with Mfg. No. 9100147 Only.
Timer Models Only.

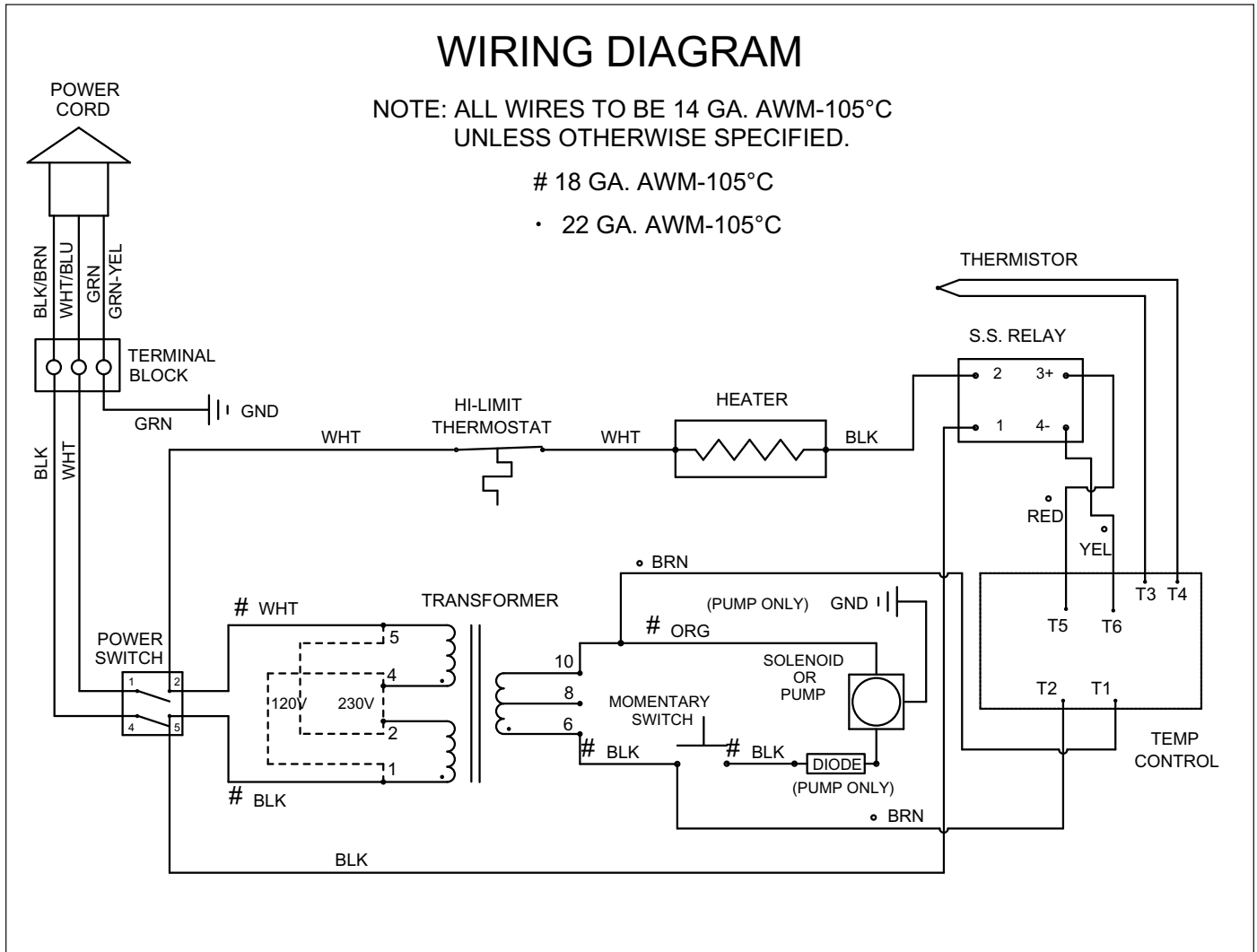

LIMITED WARRANTY

Equipment manufactured by Roundup Food Equipment Division of A.J. Antunes & Co. has been constructed of the finest materials available and manufactured to high quality standards. These units are warranted to be free from electrical and mechanical defects for a period of one (1) year from date of purchase under normal use and service, and when installed in accordance with manufacturer's recommendations. To insure continued operation of the units, follow the maintenance procedures outlined in the Owner's Manual. During the first 12 months, electro-mechanical parts, non-overtime labor, and travel expenses up to 2 hours (100 miles/160 km), round trip from the nearest Authorized Service Center are covered.

1. This warranty does not cover cost of installation, defects caused by improper storage or handling prior to placing of the Equipment. This warranty does not cover overtime charges or work done by unauthorized service agencies or personnel. This warranty does not cover normal maintenance, calibration, or regular adjustments as specified in operating and maintenance instructions of this manual, and/or labor involved in moving adjacent objects to gain access to the equipment. This warranty does not cover consumable/wear items. This warranty does not cover damage to the Load Cell or Load Cell Assembly due to abuse, misuse, dropping of unit/shock loads or exceeding maximum weight capacity (4 lbs). This warranty does not cover water contamination problems such as foreign material in water lines or inside solenoid valves. It does not cover water pressure problems or failures resulting from improper/incorrect voltage supply. This warranty does not cover Travel Time & Mileage in excess of 2 hours (100 miles/160 km) round trip from the nearest authorized service agency.
2. Roundup reserves the right to make changes in design or add any improvements on any product. The right is always reserved to modify equipment because of factors beyond our control and government regulations. Changes to update equipment do not constitute a warranty charge.
3. If shipment is damaged in transit, the purchaser should make a claim directly upon the carrier. Careful inspection should be made of the shipment as soon as it arrives and visible damage should be noted upon the carrier's receipt. Damage should be reported to the carrier. This damage is not covered under this warranty.
4. Warranty charges do not include freight or foreign, excise, municipal or other sales or use taxes. All such freight and taxes are the responsibility of the purchaser.
5. THIS WARRANTY IS EXCLUSIVE AND IS IN LIEU OF ALL OTHER WARRANTIES, EXPRESSED OR IMPLIED, INCLUDING ANY IMPLIED WARRANTY OR MERCHANTABILITY OR FITNESS FOR A PARTICULAR PURPOSE, EACH OF WHICH IS HEREBY EXPRESSLY DISCLAIMED. THE REMEDIES DESCRIBED ABOVE ARE EXCLUSIVE AND IN NO EVENT SHALL ROUNDUP BE LIABLE FOR SPECIAL CONSEQUENTIAL OR INCIDENTAL DAMAGES FOR THE BREACH OR DELAY IN PERFORMANCE OF THIS WARRANTY.



A.J. Antunes & Co.
We exist to make our customers successful.

A.J. Antunes & Co.
Headquarters/Manufacturing
Carol Stream, Illinois 60188 USA
Phone: (630) 784-1000
Toll Free: (800) 253-2991
Fax: (630) 784-1650

Antunes Equipment
Manufacturing (Suzhou) Ltd.,
Suzhou, Jiangsu, China 215011
Phone: 86-512-6841-3637
Toll Free: 400-0-7878-22
Fax: 86-512-6841-3907

www.ajantunes.com