

MS-150/155

miracle steamers

owner's manual

Manufacturing Numbers:

9100419, 9100420, 9100423, 9100425,
9100426, 9100428, 9100442, 9100450,
9100452, 9100456, 9100458, 9100459

Table of Contents

General	2
Warranty Information.....	2
Service/Technical Assistance.....	2
Important Safety Information.....	3
Warnings	3
Specifications	4
Installation	5
Electrical.....	5
Plumbing.....	5
Operating Instructions.....	6
Programming	6
Hi-Limit Reset Button.....	7
Status Indicator LEDs	7
Fault Codes	7
Daily Maintenance	7
Monthly Maintenance.....	8
Troubleshooting.....	9
Wiring Diagram	11
Replacement Parts.....	12
Limited Warranty.....	16

⚠ IMPORTANT ⚠

A.J. Antunes & Co. reserves the right to change specifications and product design without notice. Such revisions do not entitle the buyer to corresponding changes, improvements, additions or replacements for previously purchased equipment.

⚠ IMPORTANT ⚠

Keep these instructions for future reference. If the unit changes ownership, be sure this manual accompanies the equipment.

GENERAL

This manual provides the safety, installation, and operating procedures for the Miracle Steamer. We recommend that all information contained in this manual be read prior to installing and operating the unit.

The Miracle Steamer is manufactured from the finest materials available and is assembled to our strict quality standards. This unit has been tested at the factory to ensure dependable trouble-free operation.

WARRANTY INFORMATION

Please read the full text of the Limited Warranty in this manual.

If the unit arrives damaged, contact the carrier immediately and file a damage claim with them. Save all packing materials when filing a claim. Freight damage claims are the responsibility of the purchaser and are not covered under warranty.

The warranty does not extend to:

- Damages caused in shipment or damage as result of improper use.
- Installation of electrical service.
- Normal maintenance as outlined in this manual.
- Malfunction resulting from improper maintenance.
- Damage caused by abuse or careless handling.
- Damage from moisture into electrical components.
- Damage from tampering with, removal of, or changing any preset control or safety device.

SERVICE/TECHNICAL ASSISTANCE

If you experience any problems with the installation or operation of your unit, contact Antunes Technical Service at 1-877-392-7854 toll free in the U.S.) or at 630-784-1000.

Fill in the information below and have it handy when calling Antunes Technical Service for assistance. The serial number is on the specification plate located on the rear of the unit.

Purchased From

Date of Purchase

Model Number

Serial Number

Manufacturing Number

Use only genuine Antunes replacement parts in this unit. Use of replacement parts other than those supplied by the manufacturer will void the warranty.

IMPORTANT SAFETY INFORMATION

Use the following guidelines for safe operation of the unit.

- Read all instructions before using equipment.
- For your safety, the equipment is furnished with a properly grounded cord connector. Do not attempt to defeat the grounded connector.
- Install or locate the equipment only for its intended use as described in this manual. Do not use corrosive chemicals in this equipment.
- Do not operate this equipment if it has a damaged cord or plug, if it is not working properly, or if it has been damaged or dropped.
- This equipment should be serviced by qualified personnel only. Contact Antunes Technical Service for adjustment or repair.
- Do not block or cover any openings on the unit.
- Do not immerse cord or plug in water.
- Keep cord away from heated surfaces.
- Do not allow cord to hang over edge of table or counter.
- Turn the power off, unplug the power cord, and allow unit to cool down before performing any service or maintenance on the unit.
- The equipment should be grounded according to local electrical codes to prevent the possibility of electrical shock. It requires a grounded receptacle with separate electrical lines, protected by fuses or circuit breaker of the proper rating.
- All electrical connections must be in accordance with local electrical codes and any other applicable codes.
- Do not clean this appliance with a water jet.

WARNINGS

Be advised of the following warnings when operating and performing maintenance on this unit.

- If the supply cord is damaged, it must be replaced by the manufacturer or its service agent or a similarly qualified person in order to avoid a hazard.
- Do not modify the power supply cord plug. If it does not fit the outlet, have a proper outlet installed by a qualified electrician.
- Do not use an extension cord with this appliance.
- Electrical ground is required on this appliance.
- Check with a qualified electrician if you are unsure if the appliance is properly grounded.
- If a chemical cleaner is used, be sure it is safe to use on cast aluminum. Observe all precautions and warnings on product label.
- Inspection, testing, and repair of electrical equipment should only be performed by qualified service personnel.
- This equipment is to be installed to comply with the basic plumbing code of the Building Officials and Code Administrators, Inc. (BOCA) and the Food Service Sanitation Manual of the Food and Drug Administration (FDA).
- To ensure proper steaming characteristics, some calcium/mineral deposits must be present on the generator surface. If, during cleaning, the surface does become free of calcium/mineral deposits, add plain tap water to the surface and allow it to boil off. This may have to be repeated several times to ensure proper steaming characteristics by creating a thin layer of deposits on the surface.
- Do not use a sanitizing solution or abrasive materials. The use of these may cause damage to the stainless steel finish.
- Chlorides or phosphates in cleaning agents (e.g. bleach, sanitizers, degreasers or detergents) could cause permanent damage to stainless steel equipment. The damage is usually in the form of discoloration, dulling of metal surface finish, pits, voids, holes, or cracks. This damage is permanent and not covered by warranty.

- The following tips are recommended for maintenance of your stainless steel equipment:
 - Always use soft, damp cloth for cleaning, rinse with clear water and wipe dry. When required, always rub in direction of metal polish lines.
 - Routine cleaning should be done daily with soap, ammonia detergent, and water.
 - Stains and spots should be sponged using a vinegar solution.
 - Finger marks and smears should be rubbed off using soap and water.
 - Hard water spots should be removed using a vinegar solution.

SPECIFICATIONS

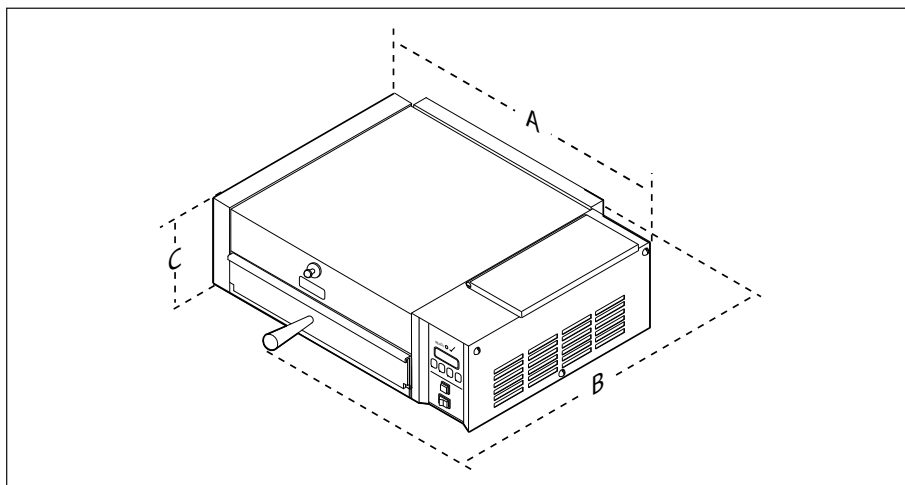

Model No.	Width (A)	Depth (B)	Height (C)
MS-150	21" (533 mm)	21 3/8" (543 mm)	10 1/4" (260 mm)
MS-155	21" (533 mm)	17 1/8" (435 mm)	10 1/4" (260 mm)

Model & Mfg. No.	Volts	Watts	Amps	Hertz	Plug Description
MS-150 9100419 Saudi Arabia	230	3300	14.4	50/60	CEE 7/7 16 Amp. 250 Volt
MS-150 9100420	208	3300	15.9	50/60	NEMA 6-20P, 20 Amp., 250 Volt
MS-150 9100423 9100425	120	1800	15.0	50/60	NEMA 5-15P 15 Amp, 120 Volt
MS-150 9100426	230	3300	14.4	50/60	NEMA 6-20P, 20 Amp., 250 Volt
MS-150 9100428	230	3300	14.4	50/60	CEE 7/7 16 Amp. 250 Volt
MS-150 9100442	208	3300	15.9	50/60	NEMA 6-20P, 20 Amp., 250 Volt
MS-155 9100450	208	3300	15.9	50/60	NEMA 6-20P, 20 Amp., 250 Volt
MS-155 9100452	120	1800	15.0	50/60	NEMA 5-15P 15 Amp, 120 Volt
MS-155 9100456	230	3300	14.4	50/60	NEMA 6-20P, 20 Amp., 250 Volt
MS-155 9100458	230	3300	14.4	50/60	CEE 7/7 16 Amp. 250 Volt
MS-155 9100459 Saudi Arabia	230	3300	14.4	50/60	IEC-309 16 Amp., 250 VAC Pin & Sleeve (Assembly Only)

Model & Mfg. No.	Agency Approvals
MS-150 MS-155	

INSTALLATION

1. Remove the unit and all packing materials from the shipping carton.
2. The unit should come with the items listed below:
 - Owner's Manual
 - Spatula Assembly (MS-150 only)
 - Drawer Assembly (MS-155 only)

NOTE: If any parts are missing or damaged, contact A.J. Antunes IMMEDIATELY at 1-800-253-2991 or 1-630-784-1000.

3. Remove all packing materials and protective coverings from the unit.
4. **MS-150:** Remove and wash the Wire Trivet, Spatula, Spatula Liner, and Drip Pan (Figure 1) in soap and water. Rinse with clean hot water and allow to air dry.

MS-155: Remove and wash the Drawer, Drawer Liner with Rollers, and Drip Pan (Figure 2) in soap and water. Rinse with clean hot water and allow to air dry.

5. Wipe all surfaces of the unit with a hot, damp cloth.

NOTE: Do NOT use a dripping wet cloth. Wring out before use.

6. **MS-150 Models:** Assemble the Handle, Handle Guard and Mounting Bolt to the Spatula (Figure 3).
7. Install the Wire Trivet into the side slots on the Spatula.
8. Re-install all removed parts.

When placing the unit into service, pay attention to the following guidelines:

- Make sure power is off and the unit is at room temperature.
- Do NOT block or cover any openings on the unit.
- Do NOT immerse cord or plug in water.
- Keep cord away from heated surfaces.
- Do NOT allow cord to hang over edge of table or counter.

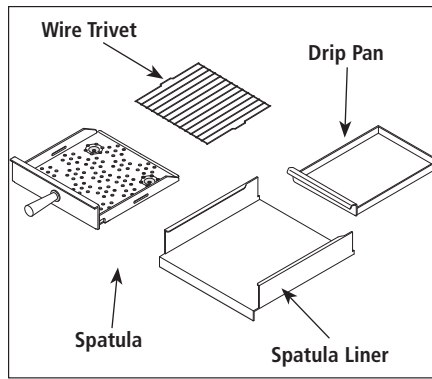

Figure 1. Washing Parts (MS-150 Only)

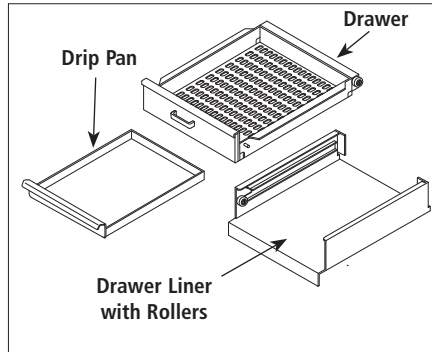

Figure 2. Washing Parts (MS-155 Only)

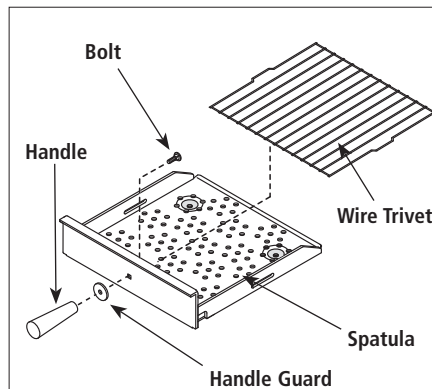

Figure 3. Assembling Handle (MS-150 Only)

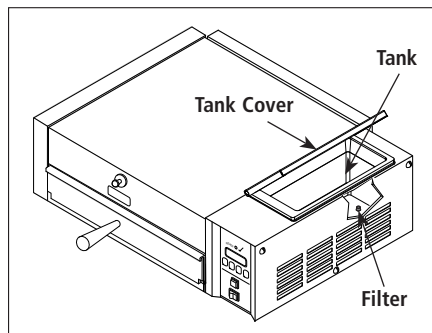

Figure 4. Filling Water Tank

⚠ WARNING ⚠

Be sure to follow all the precautions, procedures, and safety steps listed in the Important Safety Information section of this manual.

⚠ WARNING ⚠

All electrical connections must be in accordance with local electrical codes and any other applicable codes.

ELECTRICAL

Plug the power cord into the appropriate power outlet. Refer to the specification plate for the proper voltage.

1. Place the unit on a sturdy, level table or other work surface.
2. Turn off the power.
3. Ensure that the line voltage corresponds to the stated voltage on the units specification label and power cord warning tag. If you are unsure of your Line Voltage, contact an electrician.
4. Connect the unit to the power supply.

PLUMBING

NOTE: Miracle Steamer models are designed to use cold tap water. Distilled water may be used to reduce calcium/mineral deposit buildup and reduce maintenance costs.

The MS-150/155 models have a self-contained water tank. To fill the self-contained water tank:

1. Open the Tank Cover on top of the unit (Figure 4).

NOTE: Make sure filter inside tank is installed properly.

2. Pour in cold tap water. The tank will hold approximately 3 quarts (2.81 liters).
3. Close the Tank Cover.

NOTE: Do NOT overfill the unit's water tank. Only fill the tank to 90% full.

OPERATING INSTRUCTIONS

1. Turn the power on and allow the unit to preheat for approximately 20-30 minutes.

NOTE: Do NOT push any button during warmup time. The flashing green Ready Light indicates that the unit is not warmed up. The Ready Light will become steady when the unit is warmed up.

2. Pull out the Spatula or Drawer Assembly and set the product to be steamed onto the Spatula.
3. Push the Spatula or Drawer Assembly fully into the steamer.
4. **Single Shot:** Press and release the Operate button, then wait 20 seconds for the steam to penetrate the product.

Timed Cycle: Press the Start/Stop button to begin the steaming cycle. The display will count down to zero and an audio signal will sound at the end of the steaming cycle.

5. Remove steamed product.

! WARNING !

To avoid injury, be careful when pulling the spatula or drawer out from the unit. Be sure to allow steam to escape before putting hands or face over the steamer.

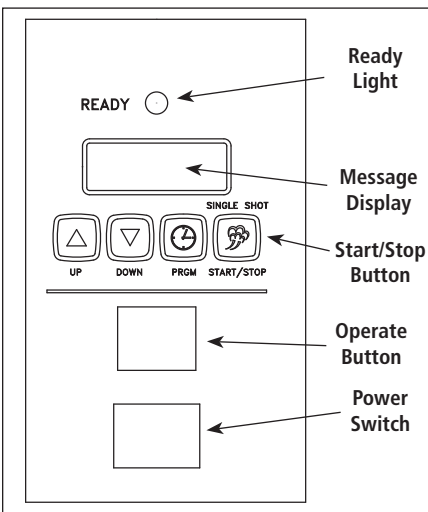

Figure 5. Operating Controls

PROGRAMMING

CYC (Total Cycle Time) refers to the total programmed steam time set for the product.

SHO (Shot Interval Time) refers to the time set between shots of steam during a complete cycle.

H2O setting (Steam Shot Time) refers to the water volume consumed during each water pump activation.

The amount of steam produced by your Miracle Steamer depends on the amount of water sprayed onto the steam generator.

Flooding of the generator may occur if the H2O setting is too high. To prevent flooding, the Shot Interval Time (SHO) can be increased to allow more time for generator heat recovery. Adjustments should be made to both values to determine the best settings for your cooking needs.

1. Turn the unit on. The unit displays the factory programmed Total Cycle Time in minutes and seconds.
2. Press and release to change the control from OPERATION to PROGRAM mode.
3. To change the Total Cycle Time in minutes, press or to change the time.
4. Press and release again, and press or to change the Total Cycle Time in seconds.
5. To change the SHO factory settings, make sure the control is in PROGRAM mode, then press and hold both and simultaneously for 1-2 seconds and release. "SHO" will be displayed.
6. Press and release and then press or to change the SHO in seconds.
7. Press and release again and press or to change the SHO in minutes.
8. Press and release again and "H2O" will be displayed.
9. To change the H2O (Steam Shot time), press and release the Program button again to display the setting. Use or to increase or decrease the time.
10. Press the Start/Stop or Operate buttons to store the changes, exit the PROGRAM Mode, and initiate the cooking cycle.

IMPORTANT: 208V and 220/240V Miracle Steamers are factory programmed for the following recommended settings:

- Total Cycle Time (CYC) = 15 min., 00 secs. (Range: 3 seconds to 99 minutes 59 seconds)
- Shot Interval Time (SHO) = 00 min., 20 secs. (Range: 3 seconds to 5 minutes 59 seconds)
- Steam Shot Time (H2O) = 1_00 (Range: 0_10 second to 2_50)

IMPORTANT: 120V Miracle Steamer is factory programmed for the following recommended settings:

- Total Cycle Time (CYC) = 2 min., 00 secs. (Range: 3 seconds to 99 minutes 59 seconds)
- Shot Interval Time (SHO) = 00 min., 20 secs. (Range: 3 seconds to 5 minutes 59 seconds)
- Steam Shot Time (H2O) = 0_80 (Range: 0_10 seconds to 2_50)

NOTE: The Start/Stop or Operate buttons may be pressed at any time during programming to store the changes and exit the PROGRAM Mode.

NOTE: If a change is not made within 5 seconds at any time during the programming process, all changes made up to that point are stored in memory and the control reverts to the OPERATION Mode.

HI-LIMIT RESET BUTTON

A hi-limit thermostat turns off electrical power to the steam generator if it overheats. To reset this thermostat, allow approximately 45 minutes for the unit to cool down, remove the black cap, and then press the Hi-Limit Reset Button located on the rear of the unit (Figure 6). If the unit requires continuous resetting, contact Antunes Technical Service.

STATUS INDICATOR LEDS

The Miracle Steamer's Control Board has four status indicator LEDs described below:

Green (Program): When lit, indicates the unit is in Program mode.

Yellow (Audio): When lit, indicates 10-15 VDC is being supplied to the audio signal. The audio signal sounds and the LED lights for approximately 3 seconds.

Red (Heat): When lit, indicates the Control Board is calling for heat by supplying 10-15 VDC to the Solid State Relay. When off, indicates that the unit is satisfied.

Green (H2O): When lit, indicates that 24 VAC is being supplied to operate the water pump. This LED is only lit for approximately 1 second.

FAULT CODES

When the programming parameters for Minutes, Seconds, SHO, or H2O have been inadvertently changed below or above their limits, the unit displays the "ERR" fault code. If this code appears, clear these settings using the procedure below:

1. Turn the unit off.
2. Press and hold the Program and Start/Stop buttons simultaneously.
3. Turn the unit on while continuing to hold the Program and Start/Stop buttons. Release the buttons when the unit stops beeping.
4. The display will now register the cycle time.

NOTE: Repeat these steps if the unit still displays the "ERR" fault code.

NOTE: It is recommended that the SHO and H2O settings be adjusted to the recommended settings shown in the Programming section of this manual.

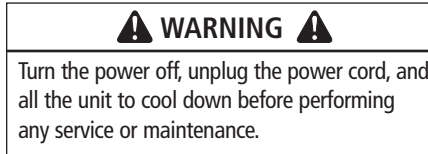
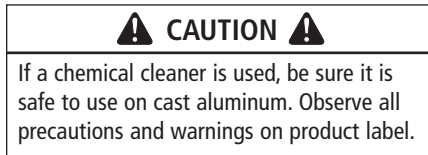
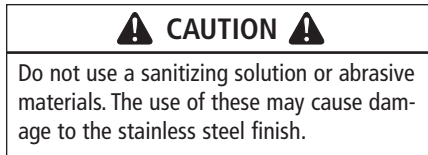

DAILY MAINTENANCE

1. Turn the power off, unplug the power cord, and allow the unit to cool down before proceeding.
2. **MS-150:** Remove the Spatula, Spatula Liner, Drip Pan, Top Cover, and Steam Vent (Figure 7).

MS-155: Remove the Drawer, Drawer Liner with Rollers, Drip Pan, Top Cover, and Steam Vent (Figure 8).

3. Wash items in hot, soapy water and then rinse and wipe dry.
4. Wipe down the food compartment and the entire exterior of the unit with a clean, hot, damp cloth (not dripping wet) and wipe dry.
5. Reinstall the Steam Vent first, followed by the remaining items.

NOTE: Frequency of cleaning is determined by water conditions, usage, and water filtration systems.

NOTE: Failure to properly clean and dry the above mentioned items prior to reassembly may result in the accumulation of water/moisture overnight. This may lead to permanent damage of the equipment's finish and its accessories. This damage is not covered by warranty.

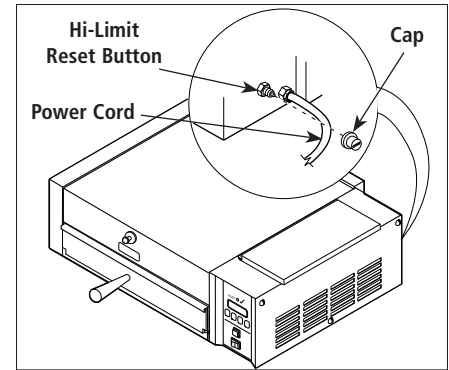

Figure 6. Hi-Limit Reset Button (MS-150 shown)

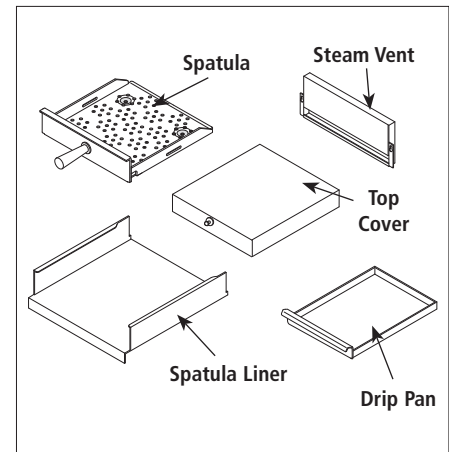

Figure 7. Daily Cleaning-MS-150

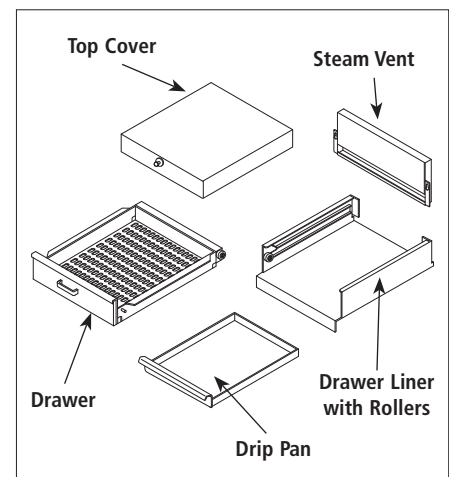

Figure 8. Daily Cleaning-MS-155

MONTHLY MAINTENANCE

The Miracle Steamer utilizes an open steam Generator. Water sprayed onto the Generator surface flashes into steam immediately, but the minerals in the water stay on the Generator surface. A small amount of calcium/mineral deposits are needed for proper operation, but a buildup of excessive calcium/mineral deposits causes poor steaming efficiency and excessive moisture (wet steam), which will eventually severely hinder the steaming action.

CLEANING STEAM GENERATOR

1. Turn the power off, unplug the power cord, and allow the unit to cool down.
2. Perform the Daily cleaning, but do NOT reassemble the unit.
3. Remove the Wing Nut, Generator Cover, and Diffuser (Figure 9). Wash these items in hot, soapy water, rinse and wipe dry.
4. With the unit cool, use a wire brush and/or scraper to loosen and remove the excessive calcium/mineral deposits from the Generator surface.
5. Take a wire brush and clean out any buildup from the 28 Steam Ports (26 vertical and 2 horizontal) of the Generator (Figure 9). Remove the loose buildup, wipe the Generator with a clean, damp cloth, and reassemble the unit.

NOTE: If deposits are still excessive and/or difficult to remove, refer to Steps 6 and 11.

6. Pour delimer solution (not supplied) onto the Generator surface. Follow the delimer manufacturer's instructions for proper mixture and use.

CAUTION

If a chemical cleaner is used, be sure it is safe to use on cast aluminum. Observe all precautions and warnings on product label.

7. Using a sponge or a dry towel, remove the delimer solution from the Generator surface, then rinse with clean water.

To ensure proper steaming characteristics, some calcium/mineral deposits must be present on the Generator surface. If, during cleaning, the surface does become free of calcium/mineral deposits, add plain tap water to the surface and allow it to boil off. If necessary, repeat this process to formulate a thin coating of calcium/mineral deposits.

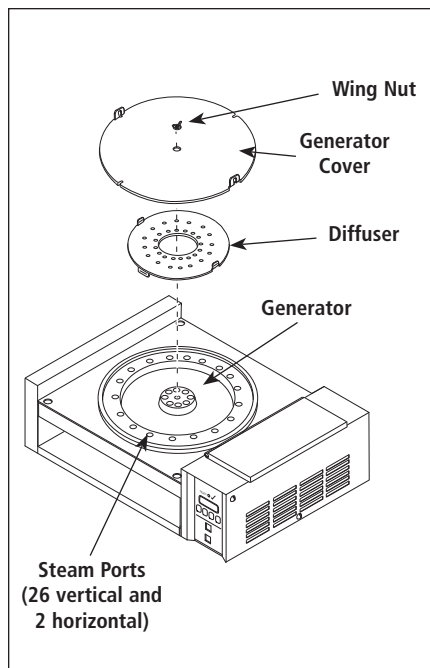

Figure 9. Monthly Cleaning

In soft water areas, it may be necessary to add a small amount of lime to the Generator to season it. This will ensure proper steaming characteristics by producing a thin coating of calcium/mineral deposits on the Generator surface.

Seasoning mixture consists of 3/4 ounces (25ml/25cc) baking soda, 3/4 ounces (25ml/25cc) lime mixed with 1 quart (950ml/950cc) of water. Stir mixture and pour 1/4" deep onto the hot Generator surface. After mixture is converted to steam, the remaining loose power can be removed.

8. Plug the power cord into the appropriate outlet.
9. Turn the power on and allow the unit to warm up for approximately 30 minutes.
10. Push and release the Operate button or the Start/Stop button several times to operate the steamer. This purges any remaining delimer residue from the Generator surface.
11. Turn the power off, reinstall all parts and accessories, and return the unit to service.

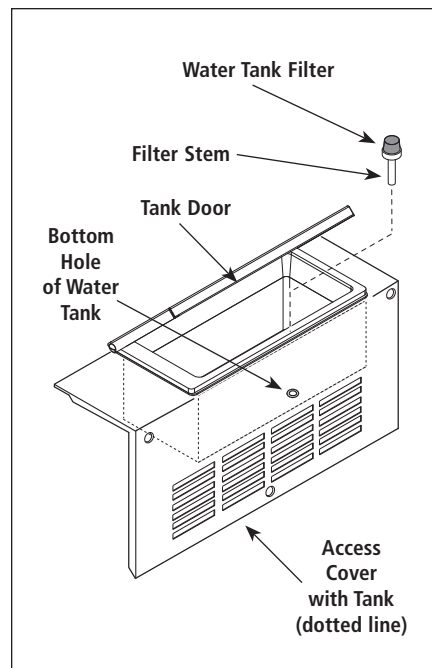

Figure 10. Water Tank Filter

WATER TANK FILTER

The Water Tank Filter (Figure 10) is used to prevent solids or food products from entering and damaging the water pump. Inspect and clean the Filter monthly or more regularly using the following procedure:

NOTE: The water level should be very low or near empty.

1. Turn the power off, unplug the power cord, and allow the unit to cool down before proceeding.
2. Open the Tank Door (Figure 10).
3. Remove the Filter, located inside the tank, by pulling it upwards and out of the bottom hole.
4. Clean the Filter by running it under tap water. Replace the Filter if the screen is torn or damaged.
5. Reinstall the Filter Stem into the bottom hole of the tank (Figure 10).
6. Fill the Water Tank, close the Tank Door, and test the unit.

NOTE: Do NOT overfill the unit's water tank. Only fill the tank to 90% full.

TROUBLESHOOTING

⚠ WARNING ⚠

To avoid possible personal injury and/or damage to the unit, inspection, test, and repair of electrical equipment should be performed by qualified service personnel. The unit should be unplugged when servicing, except when electrical tests are required. Use extreme care during electrical circuit tests. Live circuits will be exposed. If the troubleshooting steps listed below do not solve your machine's problem, contact Antunes Technical Service for further assistance.

Problem	Possible Cause	Corrective Action
Control Display is blank (power is on but indicator light is off).	The power cord is not correctly plugged in.	Plug the power cord into the appropriate outlet.
	The power cord and/or electrical plug is damaged.	Inspect electrical wire, plug, and receptacle.
	The main electrical panel circuit breaker is off or has been tripped.	Reset circuit breaker. Contact your maintenance person or Antunes Technical Service if it trips again.
	Switch is inoperable.	Contact your maintenance person or Antunes Technical Service for service.
Control Display is blank (power is on and indicator light is on).	Control Board is inoperable	Contact your maintenance person or Antunes Technical Service for service.
	Transformer is inoperable.	
	Loose, burnt, or broken wires in circuit.	
Unit does not heat up (Control Display is on).	Hi-Limit Thermostat is tripped or inoperable.	Reset the Hi-Limit Thermostat according to the Operations section of this manual. If the Hi-Limit Thermostat requires continuous resetting, contact Antunes Technical Service for service.
	Solid State Relay is inoperable.	
	Thermocouple is inoperable.	
	Control Board is inoperable.	
	Steam Generator is inoperable.	
	Loose, burnt, or broken wires in circuit.	
The unit's main electrical panel circuit breaker trips.	Damaged receptacle, plug, or cord; a loose connection; or an internal component failure.	Turn the unit off, allow it to cool down, and then restart. Contact your maintenance person or Antunes Technical Service if the condition repeats.
Water leaking inside electrical housing.	Pinhole leak in rubber hoses.	Replace hoses.
	Loose or damaged water line tubes and/or fittings inside electrical housing.	Tighten or replace tubes and/or fittings.
"ERR" appears in the Control Display.	Programming and/or SHO and H2O values were adjusted/changed improperly.	Reset the Control Board as described in the Programming section of this manual. See Fault Codes.

TROUBLESHOOTING (continued)

Problem	Possible Cause	Corrective Action
Unit heats but there is little or no steam produced and/or The product requires more steaming than usual.	Filter Strainer is restricted.	Check and clean the Filter Strainer as described in the Maintenance section of this manual.
	Unit is not being cleaned properly (daily/monthly).	Clean unit daily and monthly as described in the Maintenance section of this manual.
	Programming and/or SHO, H2O values were adjusted/changed improperly.	Reprogram the SHO and H2O values as described in the Programming section of this manual.
	Insufficient or excessive calcium/mineral deposits on the Generator surface.	Verify that thin layer of calcium/mineral deposits is present on the Generator surface. Refer to the Maintenance section of this manual.
	Generator surface is bare.	Generator surface must have a thin calcium/mineral coating for proper steaming. Refer to the Maintenance section of this manual.
	Generator Steam Ports are restricted.	Clean the Steam Ports as described in the Maintenance section of this manual.
	Generator Cover is warped or loose.	Verify that the Generator Cover Wing Nut is tight. If noticeable steam escapes around the Generator Cover, replace the cover.
	Generator Diffuser is missing.	Install Generator Diffuser or replace if missing.
	Generator surface temperature is too low.	Verify Generator surface temperature to be 380°F–420°F (193°C–215°C).
Excessive condensation in Food Compartment.	Programming and/or SHO and H2O values were adjusted improperly.	Reprogram the SHO and H2O values as described in the Programming section of this manual.
Steam coming out around top covers or sides.	Generator Cover's Wing Nut is loose.	Tighten Wing Nut.
	Generator Cover is warped.	Replace Generator Cover.

WIRING DIAGRAM

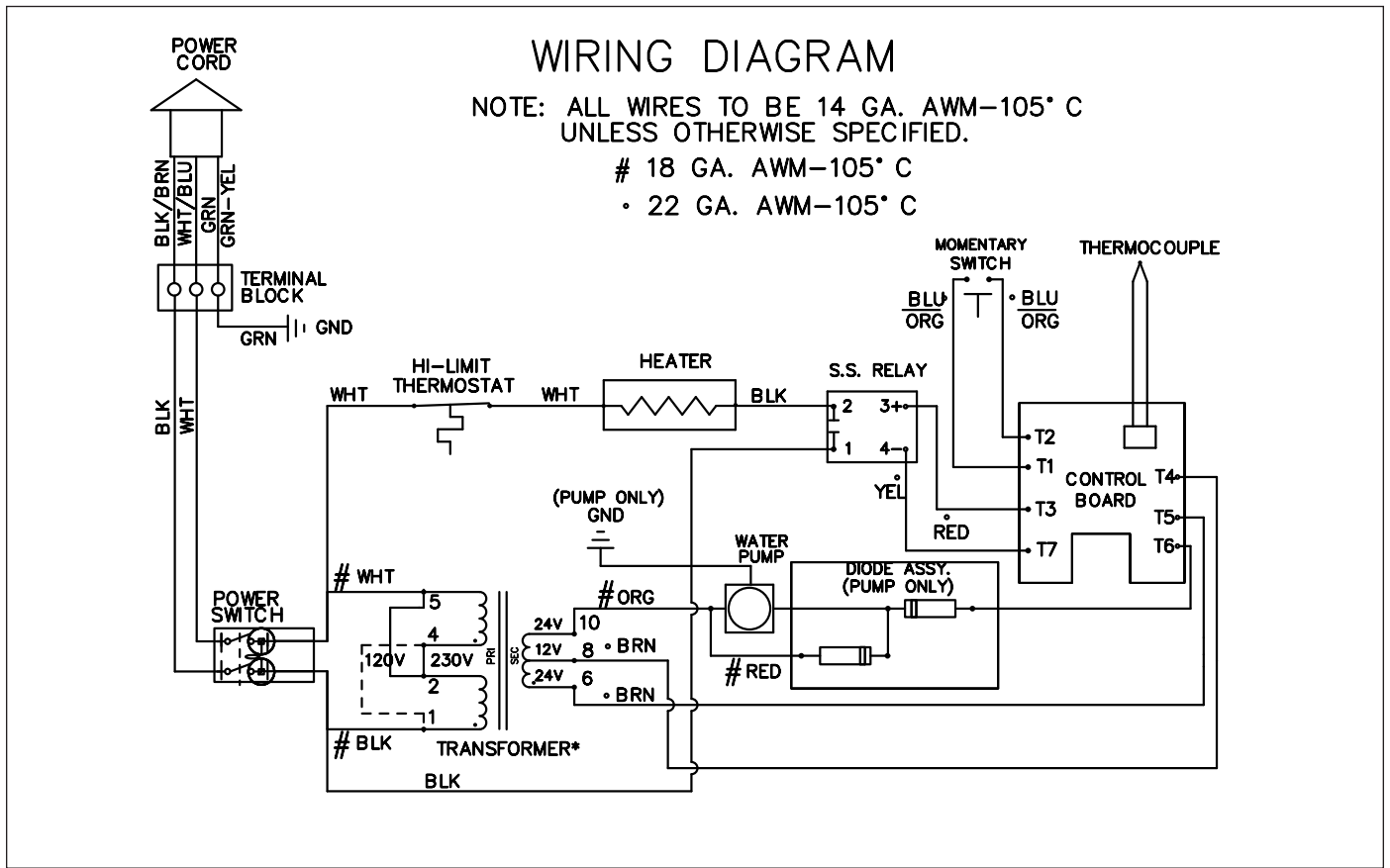

*NOTE: For 208-240 VAC units, the two primary coils are wired in series with one another. For 120 VAC units, the two primary coils are wired in parallel with one another.

REPLACEMENT PARTS

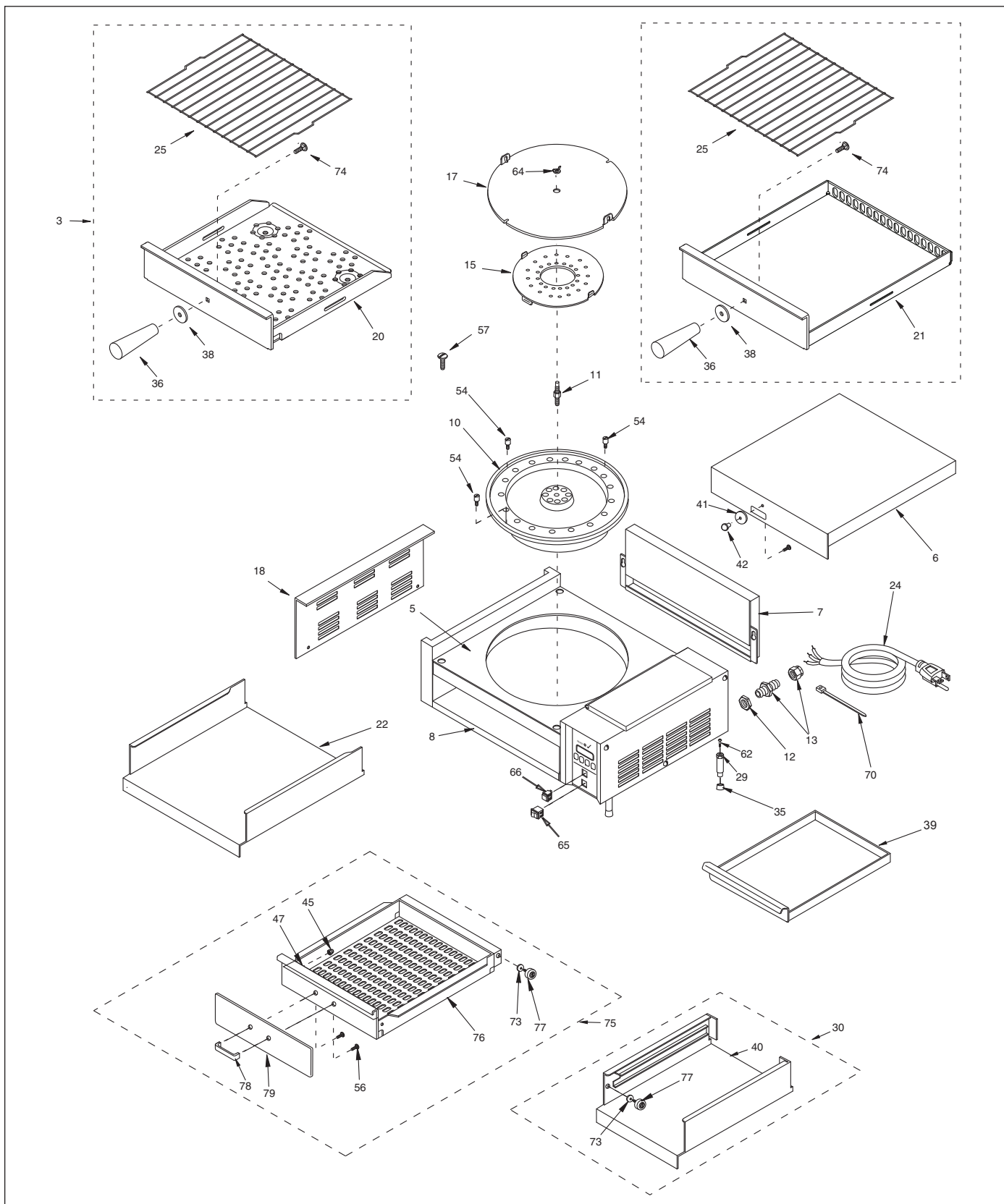

REPLACEMENT PARTS (continued)

Item	Part No.	Description	Qty.
1	0010159	Filter Assy., Water Tank	1
2	7000652	Relay	1
3	7000320	Spatula Kit (Incl. #20, 25, 36, 38, 74) (MS-150 only)	1
4	7000137	Pump/Tube Assy., 24VAC	1
5	0503429	Support, Generator Upper	1
6	7000237	Top Cover Assy. (Incl. #41 & 42)	1
7	0011314	Steam Vent Assy.	1
8	0021131	Floor/Chassis Weld.	1
9	0012298	Access Cover Weld.	1
10	7000246	Generator, 230V	1
	7000245	Generator, 208V	1
	7000300	Generator, 120V	1
11	0300129	Stud, Cover Hold Down	1
12	040P138*	Locknut, 1/2"	1
13	040K251	Strain Relief (Incl. #12)	1
14	05P2199*	Spacer	2
15	0503431	Diffuser, Steam	1
16	7000849	Silicon Tube Kit, Water Pump	1
17	0503433	Cover, Generator	1
18	0503434	Cover, End Housing	1
19	0503435	Retainer, Thermocouple	1
20	0503988	Spatula (Mfg. Nos. 9100420, 9100425, 9100426, 9100428 only)	1
21	0021571	Spatula (Mfg. No. 9100423 only)	1
22	0021314	Liner, Cavity (MS-150 only)	1
23	0503472	Bracket, Hi-Limit Support	1
24	0700452	Power Cord, NEMA 6-20P (Mfg. No. 9100420, 9100426, 9100450, & 9100456)	1
	0700453	Power Cord, CEE 7/7 (Mfg. No. 9100419, 9100428, & 9100458)	1
	0700463	Power Cord, NEMA 5-15P (Mfg. No. 9100423, 9100425, & 9100452)	1
	0700437	Power Cord IEC-309 Pin and Sleeve (Mfg. No. 9100459)	1

Item	Part No.	Description	Qty.
25	0800359	Trivet, Spatula (MS-150 only)	1
26	100P967	Label, Marking	1
27	1001036	Label, Control Panel	1
28	2000203	Tube, Restrictor, 1/4"	1
29	0011370	2" Leg Kit (Incl. #35)	4
29a	210K134	4" Leg Kit (not shown)	1
29b	210K123	4" Leg Kit (optional) (not shown)	1
30	0011413	Liner Assy. (MS-155 only)	1
31	2040106	Adapter, Tube/Hose	1
32	2040145	Elbow, Female, 1/8" x 1/4"	1
33	2040146	Tee, Female, 1/8" x 1/4"	1
34	7000693	Water Fitting Kit (Incl. #28, 31, 32, & 33)	1
35	210K108	Foot, Rubber (4 Pack)	1
36	2100119	Handle, Spatula (MS-150 only)	1
37	4050180	Heat Sink	1
38	2100118	Guard, Handle (MS-150 only)	1
39	0503536	Drip Pan	1
40	0021237	Liner Weldment (MS-155 only)	1
41	2100249	Guard, Knob	1
42	2100273	Knob	1
43	211P101	Clamp, Hose, 3/8"	1
44	211P195*	Clamp, Hose	1
45	306P107*	Acorn Nut, #6-32 (MS-155 only)	2
46	7000446	Generator Tube, 3-5/8"	2
47	306P137*	Stud, PEM, #6-32 x 3/8" (MS-155 only)	2
48	300P102*	Nut, Speed, "U", #8-32	2
49	304P105*	Nut, Hex, KEPS, #4-40, Zinc	2
50	306P101*	Nut, Hex, #6-32	2
51	306P105*	Screw, Machine, #6-32 x 1/2"	2
52	306P123*	Screw, Machine, #6-32 x 7/8"	2
53	306P130*	Nut, Hex, KEPS, #6-32	2
54	306P134*	Screw, Machine, #6-32 x 3/8"	3
55	308P103*	Screw, Machine, #8-32 x 1/4"	6
56	325P132*	Screw, Machine, 1/4-20 x 1/2" (MS-155 only)	2

Item	Part No.	Description	Qty.
57	308P105*	Screw, Machine, #8-32 x 1/2"	4
58	308P120*	Screw, Machine, #8-32 x 5/8" (sltrshd)	4
59	308P124*	Screw, Machine, #8-32 x 1/2" (one way)	1
60	308P143*	Nut, Hex, KEPS, #8-32	2
61	310P136*	Screw, Machine, #10-32 x 1-1/4" (splanhd)	4
62	310P149*	Screw, Machine, #10-32 x 7/8"	2
63	310P149*	Screw, Machine, #10-32 x 7/8" (MS-150 only)	2
64	325P170*	Nut, Wing, 1/4-20	1
65	7000542	Rocker Switch, Power On/Off 250V	1
	7000543	Rocker Switch, Power On/Off 120V	1
66	4010166	Switch, Momentary (Green)	1
	4010190	Switch, Momentary (White)	1
67	7000319	Transformer, 115-230/24V	1
68	7000135	Thermostat, Hi-Limit	1
69	4050214	Thermocouple, Type-K	1
70	406P107	Cable Tie	3
71	7000136	Terminal Block, 3-Pole	1
72	7000317	Control Board, Replacement Kit	1
	7001420	Control Board Replacement Kit (Mfg. No. 9100442 only)	1
73	05P2991	Spacer (MS-155 only)	2
74	338P102*	Bolt, Handle Mounting 1 (MS-150 only)	1
75	0011471	Drawer Assy. (Incl. #, 45, 47, 56, 73, 76, 77, 78, 79) (MS-155 only)	1
76	0021283	Drawer Weldment (MS-155 only)	1
77	210K195	Bearing, Roller, SS (Incl. #73) (MS-155 only)	4
78	2100257	Handle (MS-155 only)	1
79	2100264	Guard, Handle (MS-155 only)	1

* Only available in quantities of 10.

REPLACEMENT PARTS (continued)

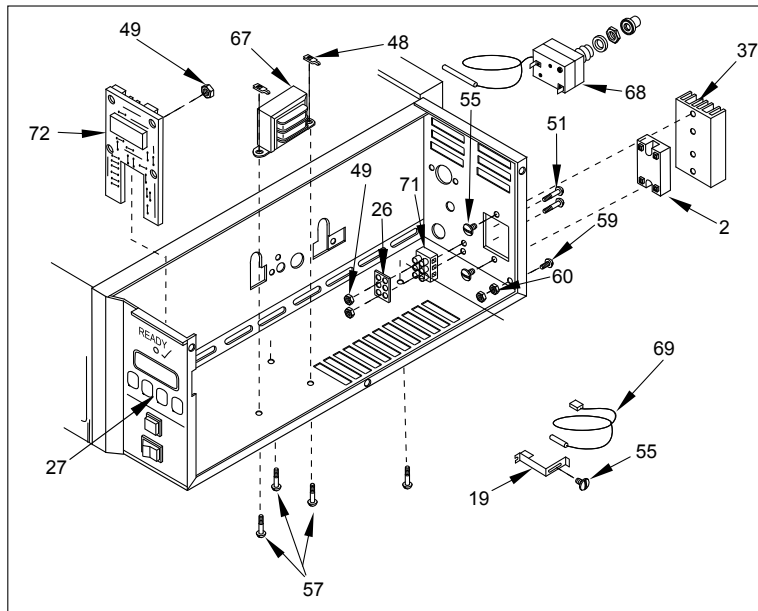
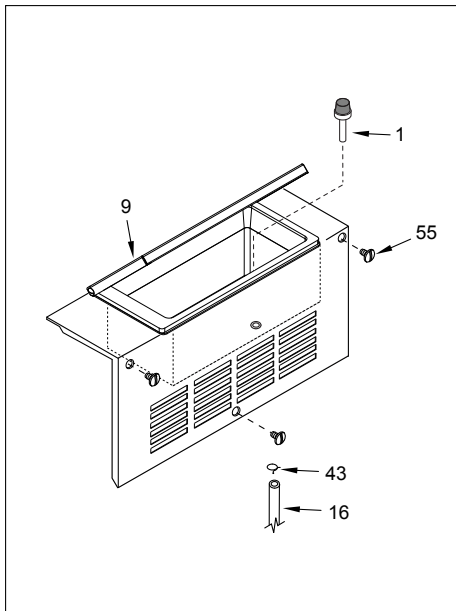
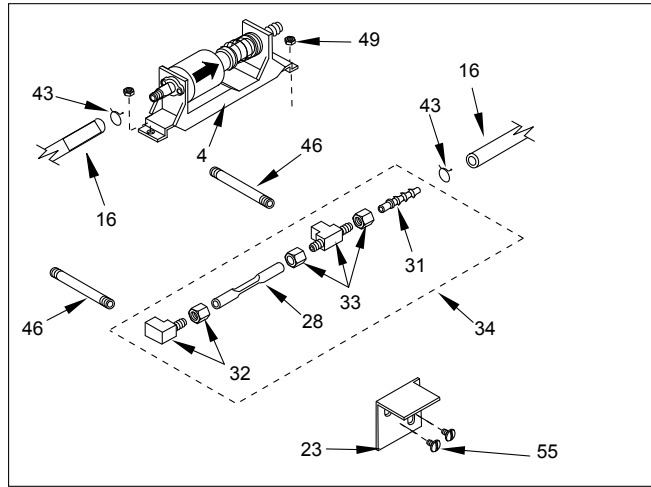
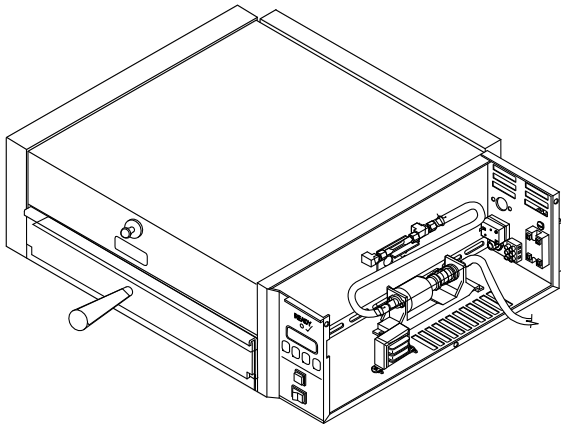

REPLACEMENT PARTS (continued)

Item	Part No.	Description	Qty.
1	0010159	Filter Assy., Water Tank	1
2	7000652	Relay	1
3	7000320	Spatula Kit (Incl. #20, 25, 36, 38, 74) (MS-150 only)	1
4	7000137	Pump/Tube Assy., 24VAC	1
5	0503429	Support, Generator Upper	1
6	7000237	Top Cover Assy. (Incl. #41 & 42)	1
7	0011314	Steam Vent Assy.	1
8	0021131	Floor/Chassis Weld.	1
9	0012298	Access Cover Weld.	1
10	7000246	Generator, 230V	1
	7000245	Generator, 208V	1
	7000300	Generator, 120V	1
11	0300129	Stud, Cover Hold Down	1
12	040P138*	Locknut, 1/2"	1
13	040K251	Strain Relief (Incl. #12)	1
14	05P2199*	Spacer	2
15	0503431	Diffuser, Steam	1
16	7000849	Silicon Tube Kit, Water Pump	1
17	0503433	Cover, Generator	1
18	0503434	Cover, End Housing	1
19	0503435	Retainer, Thermocouple	1
20	0503988	Spatula (Mfg. Nos. 9100420, 9100425, 9100426, 9100428 only)	1
21	0021571	Spatula (Mfg. No. 9100423 only)	1
22	0021314	Liner, Cavity (MS-150 only)	1
23	0503472	Bracket, Hi-Limit Support	1
24	0700452	Power Cord, NEMA 6-20P (Mfg. No. 9100420, 9100426, 9100450, & 9100456)	1
	0700453	Power Cord, CEE 7/7 (Mfg. No. 9100419, 9100428, & 9100458)	1
	0700463	Power Cord, NEMA 5-15P (Mfg. No. 9100423, 9100425, & 9100452)	1
	0700437	Power Cord IEC-309 Pin and Sleeve (Mfg. No. 9100459)	1

Item	Part No.	Description	Qty.
25	0800359	Trivet, Spatula (MS-150 only)	1
26	100P967	Label, Marking	1
27	1001036	Label, Control Panel	1
28	2000203	Tube, Restrictor, 1/4"	1
29	0011370	2" Leg Kit (Incl. #35)	4
29a	210K134	4" Leg Kit (not shown)	1
29b	210K123	4" Leg Kit (optional) (not shown)	1
30	0011413	Liner Assy. (MS-155 only)	1
31	2040106	Adapter, Tube/Hose	1
32	2040145	Elbow, Female, 1/8" x 1/4"	1
33	2040146	Tee, Female, 1/8" x 1/4"	1
34	7000693	Water Fitting Kit (Incl. #28, 31, 32, & 33)	1
35	210K108	Foot, Rubber (4 Pack)	1
36	2100119	Handle, Spatula (MS-150 only)	1
37	4050180	Heat Sink	1
38	2100118	Guard, Handle (MS-150 only)	1
39	0503536	Drip Pan	1
40	0021237	Liner Weldment (MS-155 only)	1
41	2100249	Guard, Knob	1
42	2100273	Knob	1
43	211P101	Clamp, Hose, 3/8"	1
44	211P195*	Clamp, Hose	1
45	306P107*	Acorn Nut, #6-32 (MS-155 only)	2
46	7000446	Generator Tube, 3-5/8"	2
47	306P137*	Stud, PEM, #6-32 x 3/8" (MS-155 only)	2
48	300P102*	Nut, Speed, "U", #8-32	2
49	304P105*	Nut, Hex, KEPS, #4-40, Zinc	2
50	306P101*	Nut, Hex, #6-32	2
51	306P105*	Screw, Machine, #6-32 x 1/2"	2
52	306P123*	Screw, Machine, #6-32 x 7/8"	2
53	306P130*	Nut, Hex, KEPS, #6-32	2
54	306P134*	Screw, Machine, #6-32 x 3/8"	3
55	308P103*	Screw, Machine, #8-32 x 1/4"	6
56	325P132*	Screw, Machine,	2

Item	Part No.	Description	Qty.
		1/4-20 x 1/2" (MS-155 only)	
57	308P105*	Screw, Machine, #8-32 x 1/2"	4
58	308P120*	Screw, Machine, #8-32 x 5/8" (sltrshd)	4
59	308P124*	Screw, Machine, #8-32 x 1/2" (one way)	1
60	308P143*	Nut, Hex, KEPS, #8-32	2
61	310P136*	Screw, Machine, #10-32 x 1-1/4" (splanhd)	4
62	310P149*	Screw, Machine, #10-32 x 7/8"	2
63	310P149*	Screw, Machine, #10-32 x 7/8" (MS-150 only)	2
64	325P170*	Nut, Wing, 1/4-20	1
65	7000542	Rocker Switch, Power On/Off 250V	1
	7000543	Rocker Switch, Power On/Off 120V	1
66	4010166	Switch, Momentary (Green)	1
	4010190	Switch, Momentary (White)	1
67	7000319	Transformer, 115-230/24V	1
68	7000135	Thermostat, Hi-Limit	1
69	4050214	Thermocouple, Type-K	1
70	406P107	Cable Tie	3
71	7000136	Terminal Block, 3-Pole	1
72	7000317	Control Board, Replacement Kit	1
	7001420	Control Board Replacement Kit (Mfg. No. 9100442 only)	1
73	05P2991	Spacer (MS-155 only)	2
74	338P102*	Bolt, Handle Mounting (MS-150 only)	1
75	0011471	Drawer Assy. (Incl. #, 45, 47, 56, 73, 76, 77, 78, 79) (MS-155 only)	1
76	0021283	Drawer Weldment (MS-155 only)	1
77	210K195	Bearing, Roller, SS (Incl. #73) (MS-155 only)	4
78	2100257	Handle (MS-155 only)	1
79	2100264	Guard, Handle (MS-155 only)	1

* Only available in quantities of 10.

LIMITED WARRANTY

Equipment manufactured by Roundup Food Equipment Division of A.J. Antunes & Co. has been constructed of the finest materials available and manufactured to high quality standards. These units are warranted to be free from electrical and mechanical defects for a period of one (1) year from date of purchase under normal use and service, and when installed in accordance with manufacturer's recommendations. To insure continued operation of the units, follow the maintenance procedures outlined in the Owner's Manual. During the first 12 months, electro-mechanical parts, non-overtime labor, and travel expenses up to 2 hours (100 miles/160 km), round trip from the nearest Authorized Service Center are covered.

1. This warranty does not cover cost of installation, defects caused by improper storage or handling prior to placing of the Equipment. This warranty does not cover overtime charges or work done by unauthorized service agencies or personnel. This warranty does not cover normal maintenance, calibration, or regular adjustments as specified in operating and maintenance instructions of this manual, and/or labor involved in moving adjacent objects to gain access to the equipment. This warranty does not cover consumable/wear items. This warranty does not cover damage to the Load Cell or Load Cell Assembly due to abuse, misuse, dropping of unit/shock loads or exceeding maximum weight capacity (4 lbs). This warranty does not cover water contamination problems such as foreign material in water lines or inside solenoid valves. It does not cover water pressure problems or failures resulting from improper/incorrect voltage supply. This warranty does not cover Travel Time & Mileage in excess of 2 hours (100 miles/160 km) round trip from the nearest authorized service agency.
2. Roundup reserves the right to make changes in design or add any improvements on any product. The right is always reserved to modify equipment because of factors beyond our control and government regulations. Changes to update equipment do not constitute a warranty charge.
3. If shipment is damaged in transit, the purchaser should make a claim directly upon the carrier. Careful inspection should be made of the shipment as soon as it arrives and visible damage should be noted upon the carrier's receipt. Damage should be reported to the carrier. This damage is not covered under this warranty.
4. Warranty charges do not include freight or foreign, excise, municipal or other sales or use taxes. All such freight and taxes are the responsibility of the purchaser.
5. THIS WARRANTY IS EXCLUSIVE AND IS IN LIEU OF ALL OTHER WARRANTIES, EXPRESSED OR IMPLIED, INCLUDING ANY IMPLIED WARRANTY OR MERCHANTABILITY OR FITNESS FOR A PARTICULAR PURPOSE, EACH OF WHICH IS HEREBY EXPRESSLY DISCLAIMED. THE REMEDIES DESCRIBED ABOVE ARE EXCLUSIVE AND IN NO EVENT SHALL ROUNDUP BE LIABLE FOR SPECIAL CONSEQUENTIAL OR INCIDENTAL DAMAGES FOR THE BREACH OR DELAY IN PERFORMANCE OF THIS WARRANTY.



Corporate Headquarters

Carol Stream, Illinois
Phone: +1 (630) 784-1000
Toll Free: +1 (800) 253-2991
Fax: +1 (630) 784-1650

China Facility

Suzhou, China
Phone: +86-512-6841-3637
Toll Free: +400-0-7878-22
Fax: +86-512-6841-3907