

roundup
by A.J. Antunes & Co. ®

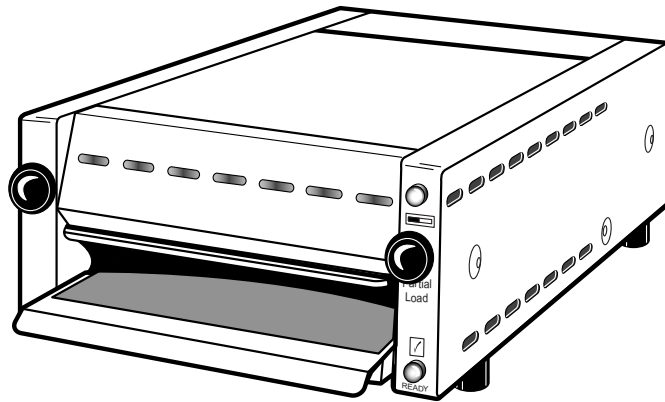

MT-12

muffin toaster

owner's manual

Manufacturing Numbers:

9200139, 9200146, 9200148

Table of Contents

General	2
Warranty Information.....	2
Service/Technical Assistance.....	2
Important Safety Information.....	3
Warnings	3
Specifications	4
Installation	5
Operation	6
Hi-Limit Reset Button.....	7
Maintenance Schedule.....	7
Function of Diagnostic LEDs.....	7
Diagnostic Flow Chart.....	8
Troubleshooting.....	9
Wiring Diagram	11
Replacement Parts.....	12
Notes.....	14
Limited Warranty.....	16

IMPORTANT

A.J. Antunes & Co. reserves the right to change specifications and product design without notice. Such revisions do not entitle the buyer to corresponding changes, improvements, additions or replacements for previously purchased equipment.

IMPORTANT

Keep these instructions for future reference. If the unit changes ownership, be sure this manual accompanies the equipment.

GENERAL

The Muffin Toaster Model MT-12 is designed to toast 6 full English muffins (12 halves) at one time. A temperature sensing solid state control measures the internal temperature of the toaster and adjusts the toasting time automatically to toast muffins faster during heavier use. The toaster signals the operator with an audible beep and a ready light when muffins are ready.

The toaster is capable of producing up to 324 muffins per hour. 6 muffin halves or less is a partial load and 7 - 12 muffin halves is a full load.

To conserve energy, when the toasting chamber is empty, the toaster idles at 600 watts. This represents a 75% reduction in operational power consumption.

This manual provides the safety, installation, and operating procedures for the unit. We recommend that all information contained in this manual be read prior to installation and operation.

This unit is manufactured from the finest materials available and is assembled to Roundup's strict quality standards. It has been tested at the factory to ensure dependable trouble-free operation.

WARRANTY INFORMATION

Please read the full text of the Limited Warranty in this manual.

If the unit arrives damaged, contact the carrier immediately and file a damage claim with them. Save all packing materials when filing a claim. Freight damage claims are the responsibility of the purchaser and are not covered under warranty.

The warranty does not extend to:

- Damages caused in shipment or damage as result of improper use.
- Installation of electrical service.
- Normal maintenance as outlined in this manual.
- Malfunction resulting from improper maintenance.
- Damage caused by abuse or careless handling.
- Damage from moisture into electrical components.
- Damage from tampering with, removal of, or changing any preset control or safety device.

SERVICE/TECHNICAL ASSISTANCE

If you experience any problems with the installation or operation of your unit, contact your local Roundup Authorized Service Agency.

Fill in the information below and have it handy when calling your Authorized Service Agency for assistance. The serial number is on the specification plate located on the rear

Purchased From

Date of Purchase

Model Number

Serial Number

Manufacturing Number

of the unit.

Use only genuine Roundup replacement parts in this unit. Use of replacement parts other than those supplied by the manufacturer will void the warranty. Your Authorized Service Agency has been factory trained and has a complete supply of parts for this toaster.

Visit www.ajantunes.com or contact the factory at 1-630-784-1000 to locate your nearest Authorized Service Agency.

Refer to the service agency directory packaged with your manual and fill in the information below.

Authorized Service Agency

Name

Phone Number

Address

IMPORTANT SAFETY INFORMATION

Use the following guidelines for safe operation of the unit.

- Read all instructions before using equipment.
- For your safety, the equipment is furnished with a properly grounded cord connector. Do not attempt to defeat the grounded connector.
- Install or locate the equipment only for its intended use as described in this manual. Do not use corrosive chemicals in this equipment.
- Do not operate this equipment if it has a damaged cord or plug, if it is not working properly, or if it has been damaged or dropped.
- This equipment should be serviced by qualified personnel only. Contact the nearest Roundup authorized service facility for adjustment or repair.
- Do not block or cover any openings on the unit.
- Do not immerse cord or plug in water.
- Keep cord away from heated surfaces.
- Do not allow cord to hang over edge of table or counter.
- Turn the unit off, unplug the power cord, and allow unit to cool down before performing any service or maintenance on the unit.
- The procedures in this manual may include the use of chemical products. These chemical products will be highlighted with bold face letters followed by the abbreviated HCS (Hazard Communication Standard). See Hazard Communication Standard manual for the appropriated Material Safety Data Sheets (MSDS).
- The equipment should be grounded according to local electrical codes to prevent the possibility of electrical shock. It requires a grounded receptacle with separate electrical lines, protected by fuses or circuit breaker of the proper rating.
- Bread may burn. Therefore toasters must not be used near or below curtains or other combustible walls and materials. Failure to maintain safe operating distances may cause discoloration or combustion.
- Do not clean this appliance with a water jet.

WARNINGS

Be advised of the following warnings when operating and performing maintenance on this unit.

- If the supply cord is damaged, it must be replaced by the manufacturer or its service agent or a similarly qualified person in order to avoid a hazard.
- Do not modify the power supply cord plug. If it does not fit the outlet, have a proper outlet installed by a qualified electrician.
- Do not use an extension cord with this appliance.
- Check with a qualified electrician if you are in doubt as to whether the appliance is properly grounded.
- If a chemical cleaner is used, be sure it is safe to use on cast aluminum. Observe all precautions and warnings on product label.
- Hot toasting surfaces will be exposed during maintenance steps. Use extreme care to avoid personal injury.
- Inspection, testing, and repair of electrical equipment should only be performed by qualified service personnel.
- Chlorides or phosphates in cleansing agents (e.g. bleach, sanitizers, degreasers or detergents) could cause permanent damage to stainless steel equipment. The damage is usually in the form of discoloration, dulling of metal surface finish, pits, voids, holes, or cracks. This damage is permanent and not covered by warranty. The following tips are recommended for maintenance of your stainless steel equipment:
 - Always use soft, damp cloth for cleaning, rinse with clear water and wipe dry. When required, always rub in direction of metal polish lines.
 - Stains and spots should be sponged using a vinegar solution.
 - Finger marks and smears should be rubbed off using soap and water.
- Check with a qualified electrician if you are in doubt as to whether the appliance is properly grounded.
- Do not use an extension cord with this appliance.
- Electrical ground is required on this appliance.

SPECIFICATIONS

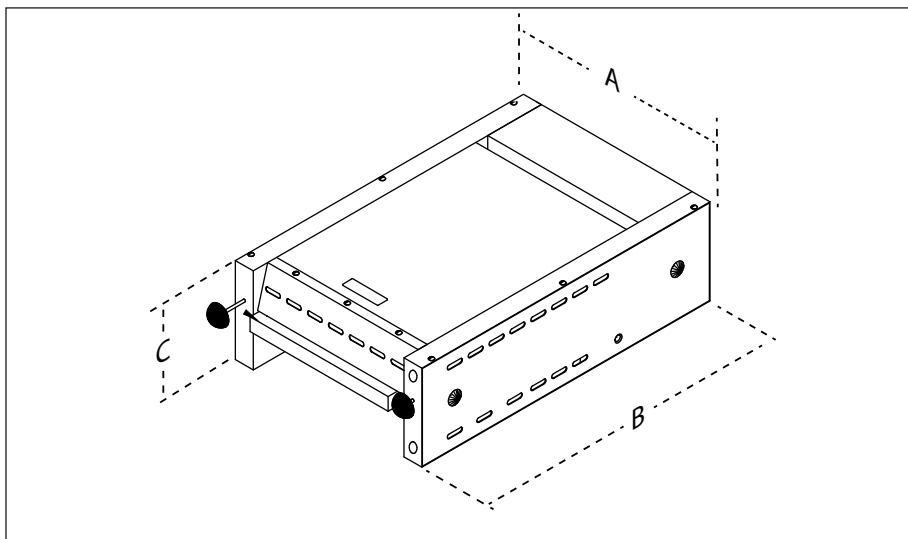

Model & Mfg. No.	Width (A)	Depth (B)	Height (C)
MT-12 9200139 9200146 9200148	15 5/8" (397 mm)	26 5/8" (676 mm)	8 1/8" (207 mm)

Model & Mfg. No.	Volts	Watts	Amps	Hertz	Plug Description	Configuration
MT-12 9200139 (Australia)	220-240	3400	15.4 - 14.2	50/60	AS3112 Australian Plug 20 Amp., 250 VAC.	
MT-12 9200146 (US & Canada)	208	3400	16.3	50/60	Straight Twist Lock L6-20P, 20 Amp., 250 VAC	
MT-12 9200148 (Europe)	220-240	3400	15.5 - 14.2	50/60	Pin & Sleeve IEC-309 16 Amp., 230 VAC (Europe)	

Model & Mfg. No.	Agency Approvals
MT-12 9200139 9200146 9200148	

INSTALLATION

1. Remove unit and all packing materials from shipping carton.
2. Open the large box. It should contain the following items:
 - Muffin Toaster with Crumb Tray
 - Information Packet
3. Remove information packet.
4. Remove all packing materials and protective coverings from the unit.

NOTE: If any parts are missing or damaged, contact Antunes IMMEDIATELY at 1-630-784-1000 or in the U.S. or Canada, 1-800-253-2991 toll free.

5. Clean the toaster with a damp cloth. Remove and clean the Crumb Tray and Removable Plate (refer to the Maintenance section of this manual).

When placing the toaster into service, pay attention to the following guidelines.

- Make sure the unit's power On/Off switch is off and the toaster is at room temperature before plugging in the power cord.
- Do not block or cover any openings on the unit.
- Do not immerse the power cord or plug in water.
- Keep the power cord away from heated surfaces.
- Do not allow the power cord to hang over edge of table or counter.

Plug the power cord into the appropriate power outlet. Refer to the specification plate for the proper voltage.

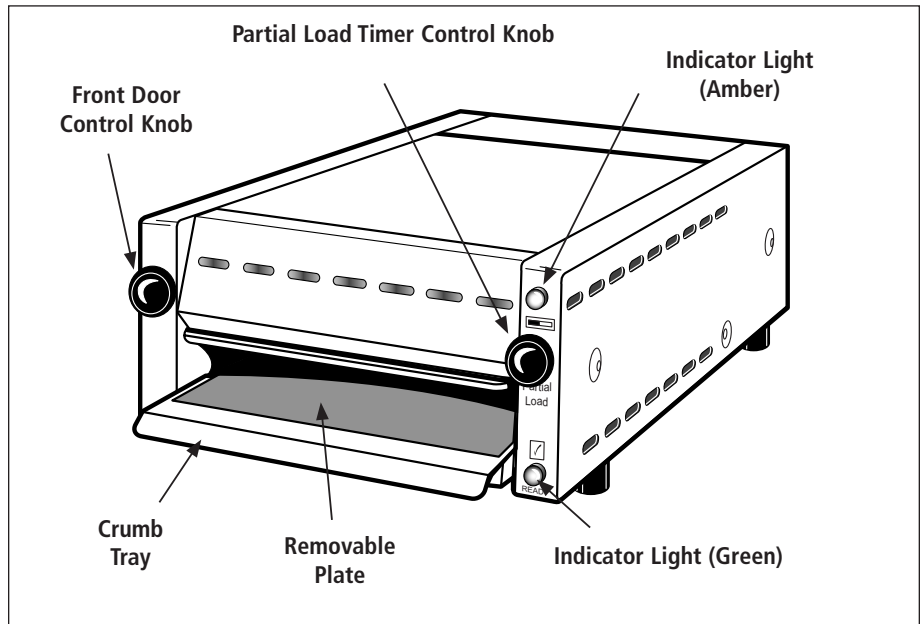

Figure 1. Muffin Toaster MT-12

OPERATION

1

A Turn Power Switch ON (Back of Unit)

B

The unit beeps twice and both lights blink twice. Allow the unit to warm up for 30 minutes.

NOTE: If the self-test fails, a series of beeps will sound (see the Diagnostic Flow Chart).

2

FULL LOAD = 7 - 12 muffin halves

PARTIAL LOAD = 1 - 6 muffin halves

NOTE: Always use a Spatula to insert and remove product from the unit. This is the only approved method for loading and unloading product into the toaster.

3

Press the Partial Load button ONLY when toasting a partial load of product.

NOTE: When the Amber light is on, a Partial Load Cycle is selected. When this light is off, a Full Load Cycle is selected.

4

A Push the Front Door Control Knob IN to UNLOCK and open the Front Door.

B Next, slide the loaded Spatula into the unit.

The Crumb Tray and Removable Plate will be very hot when the unit is in operation. Do NOT use the Crumb Tray and Removable Plate as a means to load/unload product from the unit.

5

A Pull the Front Door Control Knob OUT to close and LOCK the Front Door.

B Next, pull out the Spatula. The locked door keeps the product inside the toaster.

Do NOT toast product with the Spatula inserted in the toaster.

6

A

TOASTING TIMES:
 Full Load = 90 - 130 seconds
 Partial Load = 85 - 125 seconds

NOTE: The indicator lights blinks and the Audio Signal beeps when the toast cycle completes.

7

A

Carefully insert the Spatula into the unit. This transfers the product onto the spatula.

8

A Push the Front Door Control Knob IN to UNLOCK and open the Front Door.

B Remove the Spatula out of the unit carefully.

9

A

Remove product from the spatula. The unit is ready for another cycle.

HI-LIMIT RESET BUTTON

A hi-limit thermostat will turn off electrical power to the heater and control circuits if the unit overheats. To reset the thermostat, allow sufficient time (about 45 minutes) for the unit to cool down, remove the cap and press the red reset button located on the side of the unit (Figure 2).

If the unit requires continuous resetting, contact your Authorized Service Agency.

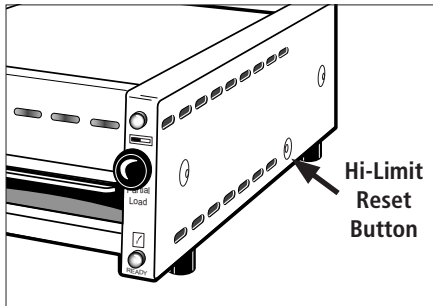

Figure 2. Hi-Limit Reset Button

MAINTENANCE SCHEDULE

DAILY – CLEAN CRUMB TRAY

1. Turn the Rocker Switch (power on/off) to OFF and unplug the power cord.
2. Allow the toaster and plate to cool sufficiently to handle.
3. From the front of the toaster, raise the Crumb Tray, and remove it from the unit (Figure 1).
4. Lift the Removable Plate from the Crumb Tray (Figure 1).
5. With a clean, damp cloth, wash the top surface of the Removable Plate.
6. Inspect the Removable Plate for excessive carbon build-up (use coloration of the bottom of the plate for reference). If there is only a slight carbon build-up, proceed to step 8.
7. If excessive build-up of carbon exists, remove with a griddle cloth.
8. Wipe the Removable Plate clean with a paper towel dampened with sanitizing solution.
9. Reinstall the Removable Plate into the Crumb Tray, reinstall the Crumb Tray into the toaster, and plug the power cord into the appropriate power outlet.

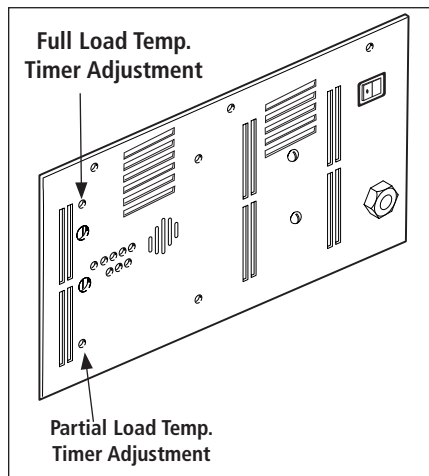

Figure 3. Timer Adjustments

MONTHLY – CHECK CALIBRATION

NOTE: You will need a stopwatch

1. Turn the Rocker Switch (power on/off) to ON and allow the unit to preheat for approximately 30 minutes.
2. Close the front door and wait for the Audio Signal to beep. When the Audio Signal beeps, open the Front Door, then close it again. When the Audio Signal beeps a second time, open the Front Door.
3. Load 12 muffin halves into the toaster, close the Front Door, and start and start the stopwatch.
4. Check the time on the stopwatch when the Audio Signal beeps.

NOTE: The Audio Signal should beep and the Ready light should come on within 90 to 130 seconds.

5. Open the Front Door to stop the Audio Signal and to turn off the Ready light.
6. Remove muffins and reload with 6 muffin halves.
7. Close the Front Door, press and release the Partial Load Control Knob on the right front of the toaster until the Amber light is lit (Figure 1). Start the stopwatch.
8. Check the time on the stopwatch when the Audio Signal beeps.

NOTE: The Audio Signal should beep and the Ready Light should come on within 85 to 125 seconds.

9. Open the Front Door to stop the Audio Signal and to turn off the Ready light.
10. If the times are correct, calibration is complete. If the times are not correct, adjust the timers located at the rear of the toaster (Figure 3).

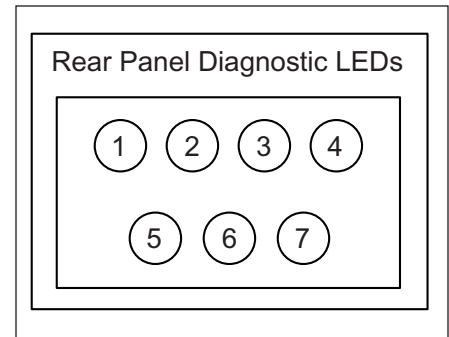

Figure 4. Diagnostic LEDs

FUNCTION OF DIAGNOSTIC LEDS

This section describes the Diagnostic LEDs and their functions. The Diagnostic LEDs (Figure 4) are found at the back of the unit.

1. Full Load Switch Light - ON when the Full Load Switch is closed.
2. Thermocouple Fault - ON when the thermocouple is disconnected or damaged. The toaster will not heat.
3. Solid State Relay On - ON when power is sent to the Solid State Relay. This LED pulses rapidly during operation.
4. Ready Light - ON when power is sent to the Ready Light.
5. Partial Load Switch - ON when the Partial Load Switch is closed.
6. Audio Signal - ON when power is sent to the Audio Signal.
7. Partial Load Light - ON when power is sent to the Partial Load Light.

DIAGNOSTIC FLOW CHART

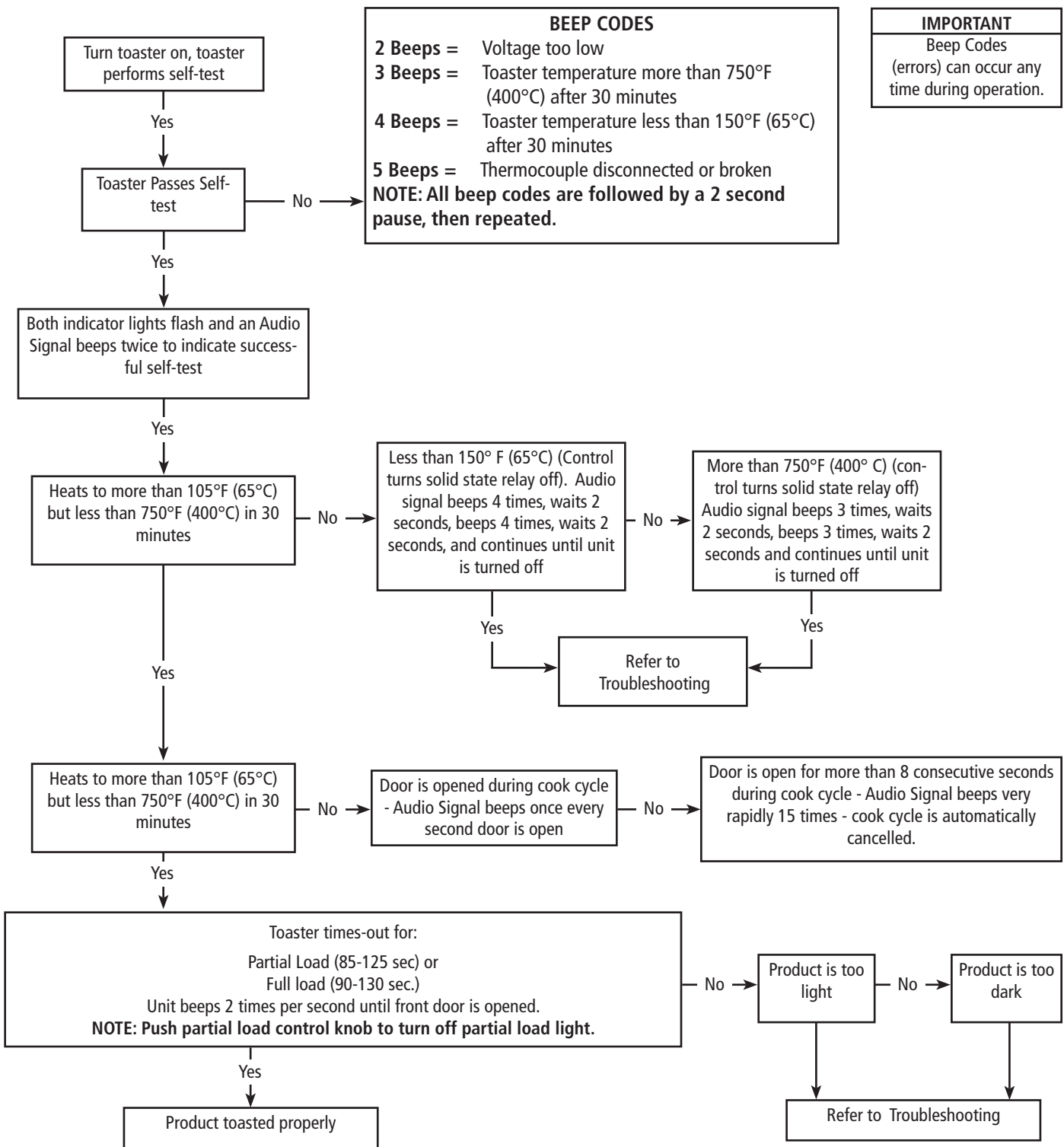

TROUBLESHOOTING

Problem	Possible Cause	Corrective Action
Muffins too light or too dark at Audio Signal.	Using refrigerated or frozen muffins.	Muffins must be at room temperature before toasting. Allow a two day old rotation when using fresh muffins.
	Incorrect setting or regional preference dictates an adjustments of the timer. Approximate times are: Partial Load - 85-125 seconds Full Load - 90-130 seconds	Adjust full or partial load timers as needed. Refer to the Maintenance section of this manual.
Toaster does not operate properly when it is initially installed.	Toaster selected/shipped is not for the electrical service as this location.	Check toaster identification plate and refer to the Electrical Specifications of this Manual.
Toaster does not operate after the replacement of a Control Board.	One or more electrical service dip switches are improperly set for the locations electrical service.	Refer to the Dip Switch setting instructions provided in this manual.
Toaster will not operate (no heat and no fan operation) and Rocker Switch not lit.	Rocker Switch (Power On/Off) not On	Confirm that the Rocker Switch is ON.
	No Power. Circuit Breaker is off or tripped.	Reset Circuit Breaker. Contact your maintenance person or Authorized Service Agency if it trips again.
	Rocker Switch is inoperable.	Replace Rocker Switch.
	Poor plug to receptacle connection.	Lock plug into receptacle.
	Damaged or defective power cord.	Inspect power cord, replace if needed.
	Damaged or defective plug, and/or pins.	Inspect plug and pins. Replace if needed.
	Damaged or defective receptacle.	Inspect receptacle. Call your electrician.
	Loose electrical connection.	Contact your maintenance person or Authorized Service Agency for service.
Toaster not heating (but fan is working.)	Hi-Limit control is tripped or defective.	Turn toaster off for 30 minutes and then reset. If the Hi-Limit control trips repeatedly, contact your maintenance person or Authorized Service Agency.
	Loose/defective electrical connections.	Contact your maintenance person or Authorized Service Agency.
	Heating element/coil is broken/open.	
	Solid State Heater Relay is defective.	
	Control Board is defective.	
Fan not running but toaster is heating.	Fan is dirty or defective.	Clean or replace defective fan.
No Audio Signal, but Ready Light works.	Defective Audio Signal.	If Audio Diagnostic LED is on but there is no Audio Signal, replace the Audio Signal.
No Ready Light but Audio Signal works.	Defective Ready Light.	If Ready Light Diagnostic LED is on, but the ready light is not, replace the ready light.
No Audio Signal or Ready light on either Full or Partial Load cycles.	Control Board is Defective.	Replace the Control Board.
Front Door will not open or close properly.	Door Push Rod is Damaged.	Remove left cover and check Door Push rod for free movement of door. Straighten or replace rod as required.
		Have your maintenance person or Authorized Service Agency straighten or replace the Door Push Rod as required.
Heating element/coil is on continuously	Defective Solid State Relay.	Contact your maintenance person or your Authorized Service Agency.
	Defective Control board.	
Only Half the element coil is working	Loose/defective electrical wiring connection.	Check wiring connections at element/coil
	Heating element/coil is broken/open	Replace the heating element/coil.

Dip Switch Settings

Check your Control Board assembly to insure the Dip Switch settings are correct.

NOTE: Refer to the table below for a listing of Manufacturing numbers that use the 220 or 200 setting.

DO NOT USE HIGH SETTING.

Mfg. No.	200 or 220?	LO or High?
9200139	220	LO
9200146	200	LO
9200148	220	LO

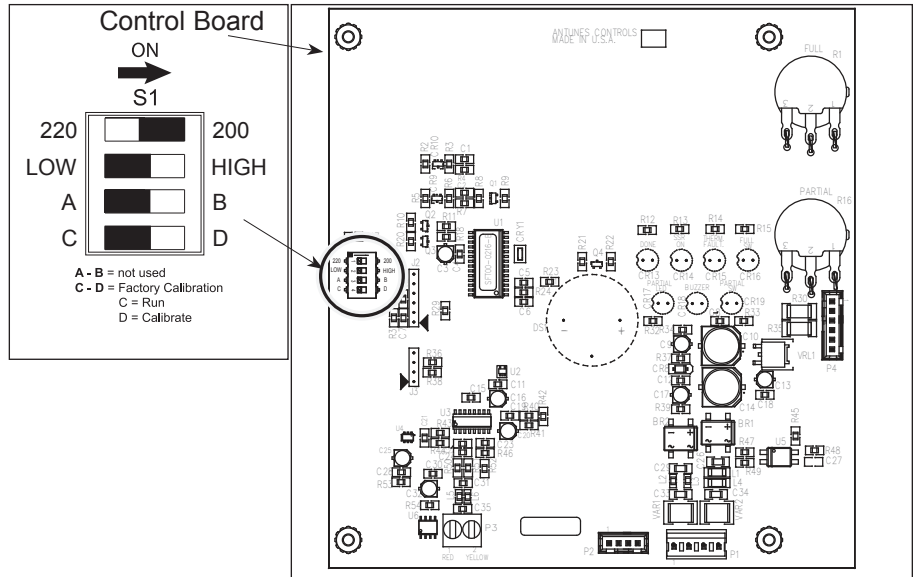

WIRING DIAGRAM

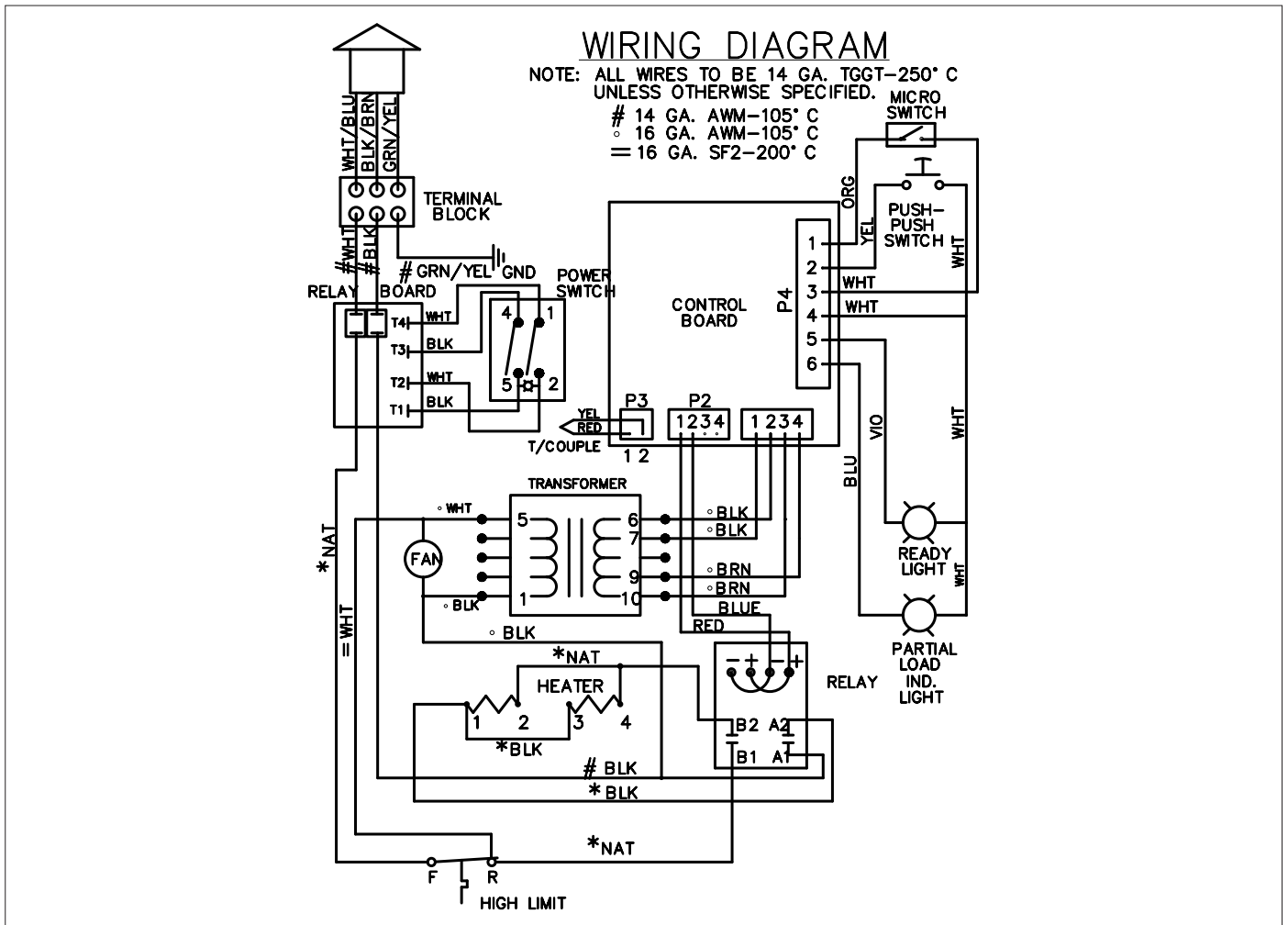

REPLACEMENT PARTS

Item	Part No.	Description	Qty.	Item	Part No.	Description	Qty.	Item	Part No.	Description	Qty.
1	0502891	Cover, Left	1	19	0400315	Strain Relief	1	40	7000401	Bushing & Retainer Kit1	
2	0800298	Rod, Door	1	20	0700697	Power Cord - Aust.	1	41	301P106*	Weld Nut	1
3	0400283	Insulation, Side	2		0700552	Power Cord - Domestic	1	42	306P102*	Lockwasher, #6	1
4	0502868	Guide, Actuator	1			20 Amp Twist Lock		43	306P115	Screw, #6-32 x 1"	1
5	210K230	Bumper, 1 Leg Kit (pack of 4)	1		0700437	Power Cord - Int'l.	1	44	306P123*	Screw, #6-32 x 7/8"	1
6	0502884	Pan, Base	1			16 Amp IEC-309		45	306P130*	Nut, Hex, KEPS, #6-32	1
7	2100132	Knob, Black	2	22	0502886	Panel, Rear	1	46	308P103*	Screw, #8-32 x 1/4"	1
8	0020186	Front Door	1	23	7000664	Control Board Kit	1	47	308P124*	Screw, #8-32 x 1/2", One-way	1
9	05K2880	Plate, Removable	1	24	7000156	Audio Signal	1	48	308P133*	Screw, #8-32 x 1/4"	1
10	0502889	Crumb Tray	1	25	050K128	Sensor Bracket Kit	1	49	308P143*	Nut, Hex, KEPS, #8-32	1
11	0502871	Retainer, Heater	1	26	0011036	Fan Assy.	1	50	308P151*	Screw, SEMS, #8-32 x 5/16"	10
12	7000114	220V Heating Element (Mfg. No. 9200139 & 9200148)	1	27	4010103	Micro Switch	1	51	306P104*	Screw, #6-32 x 1/4"	1
	7000113	200V Heating Element (Mfg. No. 9200146)	1	28	7000342	Indicator Light Kit, Green & Amber	1	52	300P117*	Washer, Retaining	1
13	0502885	Panel, Face	1	30	0800297	Rod, Partial	1	53	040P111*	Bushing, Shorty, 1/2"	1
14	0502881	Housing, Top	1	31	7000344	Hi-Limit Kit	1	54	310P140*	Washer, Flat, #10	1
15	0502890	Cover, Right	1	32	0502873	Bracket, Hi-Limit	1	55	4060374	Ground Lug	1
16	4050180	Heat Sink	1	33	4010171	Switch, Push-Push	1	56	0020995	Side Panel (RH) Weldment	1
17	7000315	Relay, Solid State, Double Pole	1	34	7000348	Thermocouple	1	57	0020996	Side Panel (LH) Weldment	1
18	7000542	Switch, Rocker Kit (Power On/Off)	1	35	406K006	Terminal Block Kit	1	58	4070106	Relay Board, 25 Amp.	1
				36	4010170	Transformer	1			* Available only in packages of 10.	
				37	1000936	Label, Front Panel	1				
				38	0600113	Spring, Front Door	1				
				39	040P119*	Bushing, Shorty, 5/8"	1				

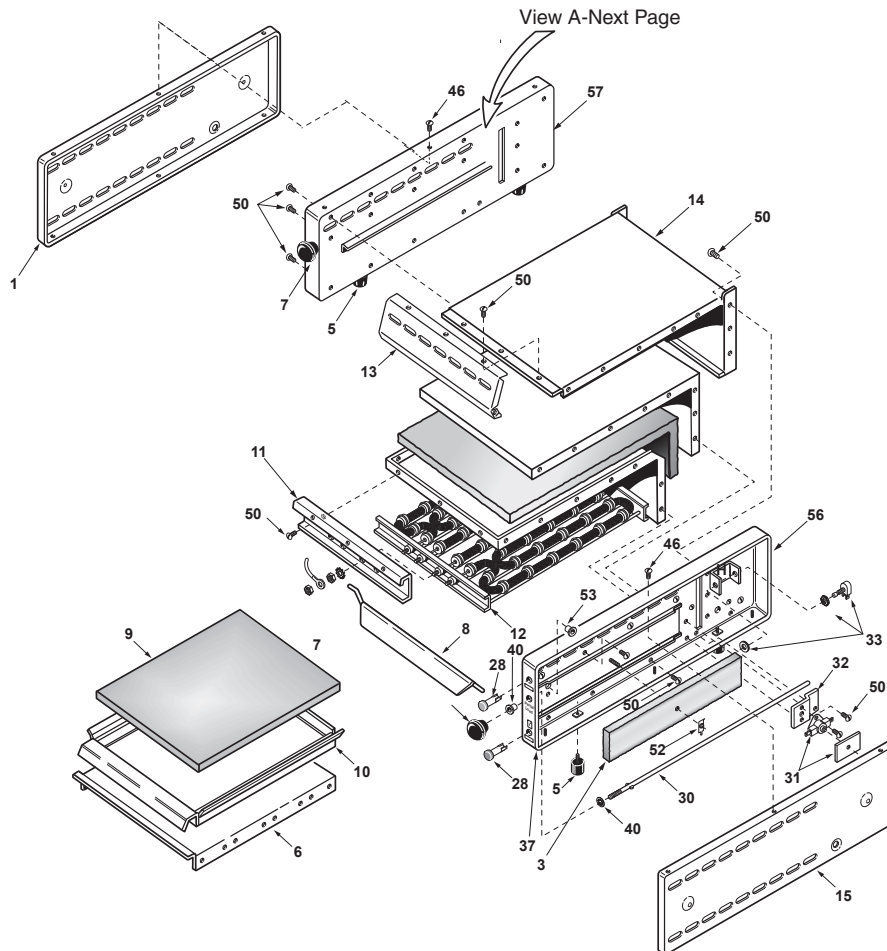

REPLACEMENT PARTS (continued)

Item	Part No.	Description	Qty.
1	0502891	Cover, Left	1
2	0800298	Rod, Door	1
3	0400283	Insulation, Side	2
4	0502868	Guide, Actuator	1
5	210K230	Bumper, 1 Leg Kit (pack of 4)	1
6	0502884	Pan, Base	1
7	2100132	Knob, Black	2
8	0020186	Front Door	1
9	05K2880	Plate, Removable	1
10	0502889	Crumb Tray	1
11	0502871	Retainer, Heater	1
12	7000114	220V Heating Element (Mfg. No. 9200139 & 9200148)	1
	7000113	200V Heating Element (Mfg. No. 9200146)	1
13	0502885	Panel, Face	1
14	0502881	Housing, Top	1
15	0502890	Cover, Right	1
16	4050180	Heat Sink	1
17	7000315	Relay, Solid State, Double Pole	1
18	7000542	Switch, Rocker Kit (Power On/Off)	1

Item	Part No.	Description	Qty.
19	0400315	Strain Relief	1
20	0700697	Power Cord - Aust. 20A, 250V	1
	0700552	Power Cord - Domestic 20 Amp Twist Lock	1
	0700437	Power Cord - Int'l. 16 Amp IEC-309	1
22	0502886	Panel, Rear	1
23	7000664	Control Board Kit	1
24	7000156	Audio Signal	1
25	050K128	Sensor Bracket Kit	1
26	0011036	Fan Assy.	1
27	4010103	Micro Switch	1
28	7000342	Indicator Light Kit, Green & Amber	1
30	0800297	Rod, Partial	1
31	7000344	Hi-Limit Kit	1
32	0502873	Bracket, Hi-Limit	1
33	4010171	Switch, Push-Push	1
34	7000348	Thermocouple	1
35	406K006	Terminal Block Kit	1
36	4010170	Transformer	1
37	1000936	Label, Front Panel	1
38	0600113	Spring, Front Door	1
39	040P119*	Bushing, Shorty, 5/8"	1

Item	Part No.	Description	Qty.
40	7000401	Bushing & Retainer Kit1	1
41	301P106*	Weld Nut	1
42	306P102*	Lockwasher, #6	1
43	306P115	Screw, #6-32 x 1"	1
44	306P123*	Screw, #6-32 x 7/8"	1
45	306P130*	Nut, Hex, KEPS, #6-32	1
46	308P103*	Screw, #8-32 x 1/4"	1
47	308P124*	Screw, #8-32 x 1/2", One-way	1
48	308P133*	Screw, #8-32 x 1/4"	1
49	308P143*	Nut, Hex, KEPS, #8-32	1
50	308P151*	Screw, SEMS, #8-32 x 5/16"	10
51	306P104*	Screw, #6-32 x 1/4"	1
52	300P117*	Washer, Retaining	1
53	040P111*	Bushing, Shorty, 1/2"	1
54	310P140*	Washer, Flat, #10	1
55	4060374	Ground Lug	1
56	0020995	Side Panel (RH) Weldment	1
57	0020996	Side Panel (LH) Weldment	1
58	4070106	Relay Board, 25 Amp.	1

* Available only in packages of 10.

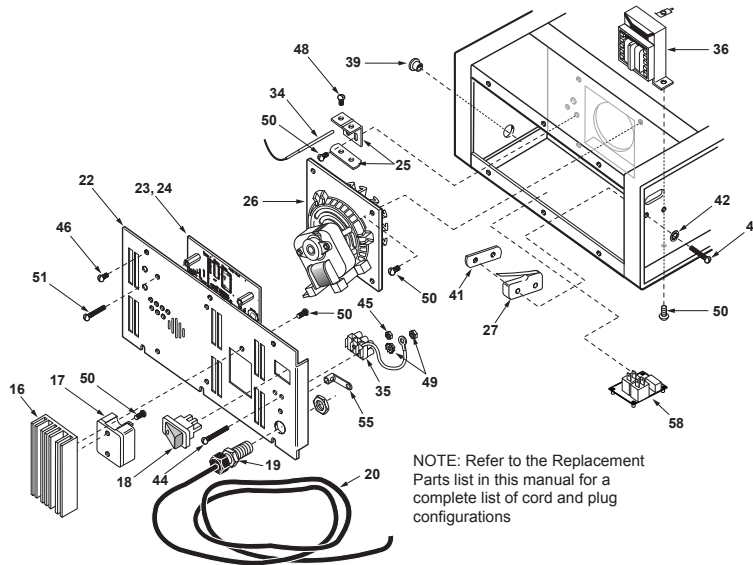

View A

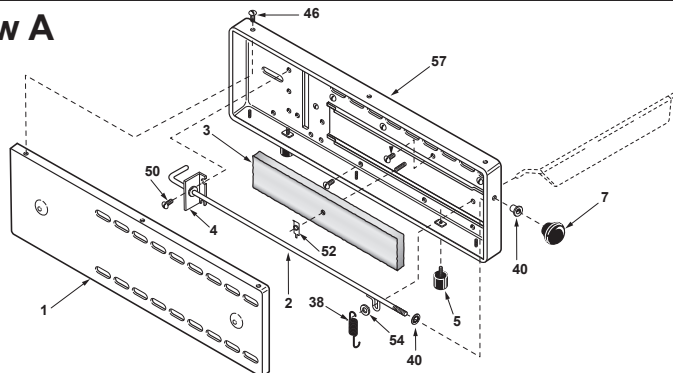

LIMITED WARRANTY

Equipment manufactured by Roundup Food Equipment Division of A.J. Antunes & Co. has been constructed of the finest materials available and manufactured to high quality standards. These units are warranted to be free from electrical and mechanical defects for a period of one (1) year from date of purchase under normal use and service, and when installed in accordance with manufacturer's recommendations. To insure continued operation of the units, follow the maintenance procedures outlined in the Owner's Manual. During the first 12 months, electro-mechanical parts, non-overtime labor, and travel expenses up to 2 hours (100 miles/160 km), round trip from the nearest Authorized Service Center are covered.

1. This warranty does not cover cost of installation, defects caused by improper storage or handling prior to placing of the Equipment. This warranty does not cover overtime charges or work done by unauthorized service agencies or personnel. This warranty does not cover normal maintenance, calibration, or regular adjustments as specified in operating and maintenance instructions of this manual, and/or labor involved in moving adjacent objects to gain access to the equipment. This warranty does not cover consumable/wear items. This warranty does not cover damage to the Load Cell or Load Cell Assembly due to abuse, misuse, dropping of unit/shock loads or exceeding maximum weight capacity (4 lbs). This warranty does not cover water contamination problems such as foreign material in water lines or inside solenoid valves. It does not cover water pressure problems or failures resulting from improper/incorrect voltage supply. This warranty does not cover Travel Time & Mileage in excess of 2 hours (100 miles/160 km) round trip from the nearest authorized service agency.
2. Roundup reserves the right to make changes in design or add any improvements on any product. The right is always reserved to modify equipment because of factors beyond our control and government regulations. Changes to update equipment do not constitute a warranty charge.
3. If shipment is damaged in transit, the purchaser should make a claim directly upon the carrier. Careful inspection should be made of the shipment as soon as it arrives and visible damage should be noted upon the carrier's receipt. Damage should be reported to the carrier. This damage is not covered under this warranty.
4. Warranty charges do not include freight or foreign, excise, municipal or other sales or use taxes. All such freight and taxes are the responsibility of the purchaser.
5. THIS WARRANTY IS EXCLUSIVE AND IS IN LIEU OF ALL OTHER WARRANTIES, EXPRESSED OR IMPLIED, INCLUDING ANY IMPLIED WARRANTY OR MERCHANTABILITY OR FITNESS FOR A PARTICULAR PURPOSE, EACH OF WHICH IS HEREBY EXPRESSLY DISCLAIMED. THE REMEDIES DESCRIBED ABOVE ARE EXCLUSIVE AND IN NO EVENT SHALL ROUNDUP BE LIABLE FOR SPECIAL CONSEQUENTIAL OR INCIDENTAL DAMAGES FOR THE BREACH OR DELAY IN PERFORMANCE OF THIS WARRANTY.



A.J. Antunes & Co.

We exist to make our customers successful.

A.J. Antunes & Co.
Headquarters/Manufacturing
Carol Stream, Illinois 60188 USA
Phone: (630) 784-1000
Toll Free: (800) 253-2991
Fax: (630) 784-1650

Antunes Equipment
Manufacturing (Suzhou) Ltd.,
Suzhou, Jiangsu, China 215011
Phone: 86-512-6841-3637
Toll Free: 400-0-7878-22
Fax: 86-512-6841-3907

www.ajantunes.com