

# Vertical Contact Toaster

## Model VCT-1000 owner's manual

**Manufacturing Numbers:**

9210700, 9210702, 9210704, 9210705, 9210706,  
9210707 9210708, 9210709, 9210710, 9210711,  
9210712, 9210713, 9210714, 9210716, 9210720,  
9210722, 9210727



## CONTENTS

<b>GENERAL</b>	<b>2</b>
<b>Warranty</b>	
<b>Information</b>	<b>2</b>
<b>Service/Technical Assistance</b>	<b>2</b>
<b>Important Safety Information</b>	<b>3</b>
<b>Warnings</b>	<b>3</b>
<b>Specifications</b>	<b>4</b>
<b>Installation</b>	<b>5</b>
Unpacking	5
Assembling the Unit	5
Equipment Setup	6
<b>Operating Instructions</b>	<b>6</b>
<b>Safety Features</b>	<b>6</b>
Hi-Limit Reset Button	6
<b>Maintenance</b>	<b>7</b>
Daily	7
Replacing the Black and Silver Release Sheet (Every 4–6 weeks)	7
Replacing the Optional Belt Wraps (Every 3–6 months)	7
Checking the Conveyor Belt Chains	8
Checking the Roller Tensioners (every 3–6 months)	9
<b>TROUBLESHOOTING</b>	<b>10</b>
<b>Wiring Diagram</b>	<b>12</b>
<b>Replacement Parts</b>	<b>13</b>
Parts Identification	13
Mechanical Butter Wheel Kit (P/N 7000298) Requires Professional Installation.	18
Mechanical Butter Wheel Kit (model 7000238)	18
<b>Notes</b>	<b>19</b>
Limited Warranty	20

## GENERAL

This manual provides the safety, installation, and operating procedures for your toaster. Please read all of the information contained in this manual prior to installing and operating the toaster.

Your toaster is manufactured from the finest materials available and is assembled to our strict quality standards. This toaster was tested at the factory to ensure dependable trouble-free operation.

## WARRANTY INFORMATION

Please read the full text of the Limited Warranty in this manual.

If the unit arrives damaged, contact the carrier immediately and file a damage claim with them. Save all packing materials when filing a claim. Freight damage claims are the responsibility of the purchaser and are not covered under warranty.

The warranty does not extend to:

- Damages caused in shipment or damage as result of improper use.
- Installation of electrical service.
- Normal maintenance as outlined in this manual.
- Malfunction resulting from improper maintenance.
- Damage caused by abuse or careless handling.
- Damage from moisture into electrical components.

Damage from tampering with, removal of, or changing any preset control or safety device.

## SERVICE/TECHNICAL ASSISTANCE

If you experience any problems with the installation or operation of your system, contact Antunes Technical Service at +1-877-392-7854 (toll free).

Fill in the information in the next column and have it handy when calling for assistance. The serial number is on the specification plate located on the system.

---

Purchased From

---

Date of Purchase

---

Model Number

---

Serial Number

---

Mfg. Number

Use only genuine Antunes replacement parts in this unit. Use of replacement parts other than those supplied by the manufacturer will void the warranty.

### IMPORTANT

**Antunes reserves the right to change specifications and product design without notice. Such revisions do not entitle the buyer to corresponding changes, improvements, additions or replacements for previously purchased equipment.**

### IMPORTANT

**Keep these instructions for future reference. If the unit changes ownership, be sure this manual accompanies the equipment.**

## IMPORTANT SAFETY INFORMATION

Use the following guidelines for safe operation of the unit.

- Read all instructions before using equipment.
- For your safety, the equipment is furnished with a properly grounded cord connector. Do not attempt to defeat the grounded connector.
- Install or locate the equipment only for its intended use as described in this manual. Do not use corrosive chemicals in this equipment.
- Do not operate this equipment if it has a damaged cord or plug, if it is not working properly, or if it has been damaged or dropped.
- This equipment should be serviced by qualified personnel only. Contact Antunes Technical Service for adjustment or repair.
- Do not block or cover any openings on the unit.
- Do not immerse cord or plug in water.
- Keep cord away from heated surfaces.
- Do not allow cord to hang over edge of table or counter.
- Turn the power off, unplug the power cord, and allow unit to cool down before performing any service or maintenance on the unit.
- The procedures in this manual may include the use of chemical products. See Hazard Communication Standard manual for the appropriated Material Safety Data Sheets (MSDS).
- The equipment should be grounded according to local electrical codes to prevent the possibility of electrical shock. It requires a grounded receptacle with separate electrical lines, protected by fuses or circuit breaker of the proper rating.
- All electrical connections must be in accordance with local electrical codes and any other applicable codes.
- Do not clean this appliance with a water jet.

## WARNINGS

Be advised of the following warnings when operating and performing maintenance on this unit.

- If the supply cord is damaged, it must be replaced by the manufacturer or its service agent or a similarly qualified person in order to avoid a hazard.
- Do not modify the power supply cord plug. If it does not fit the outlet, have a proper outlet installed by a qualified electrician.
- Do not use an extension cord with this appliance.
- Electrical ground is required on this appliance.
- Check with a qualified electrician if you are unsure if the appliance is properly grounded.
- If a chemical cleaner is used, be sure it is safe to use on cast aluminum. Observe all precautions and warnings on product label.
- Inspection, testing, and repair of electrical equipment should only be performed by qualified service personnel.
- This equipment is to be installed to comply with the basic plumbing code of the Building Officials and Code Administrators, Inc. (BOCA) and the Food Service Sanitation Manual of the Food and Drug Administration (FDA).
- To ensure proper steaming characteristics, some calcium/mineral deposits must be present on the generator surface. If, during cleaning, the surface does become free of calcium/mineral deposits, add plain tap water to the surface and allow it to boil off. This may have to be repeated several times to ensure proper steaming characteristics by creating a thin layer of deposits on the surface.
- Do not use a sanitizing solution or abrasive materials. The use of these may cause damage to the stainless steel finish.
- Chlorides or phosphates in cleaning agents (e.g. bleach, sanitizers, degreasers or detergents) could cause permanent damage to stainless steel equipment. The damage is usually in the form of discoloration, dulling of metal surface finish, pits, voids, holes, or cracks. This damage is permanent and not covered by warranty.

The following tips are recommended for maintenance of your stainless steel equipment:

- Always use soft, damp cloth for cleaning, rinse with clear water and wipe dry. When required, always rub in direction of metal polish lines.
- Routine cleaning should be done daily with soap, ammonia detergent, and water.
- Stains and spots should be sponged using a vinegar solution.
- Finger marks and smears should be rubbed off using soap and water.
- Hard water spots should be removed using a vinegar solution.

# SPECIFICATIONS

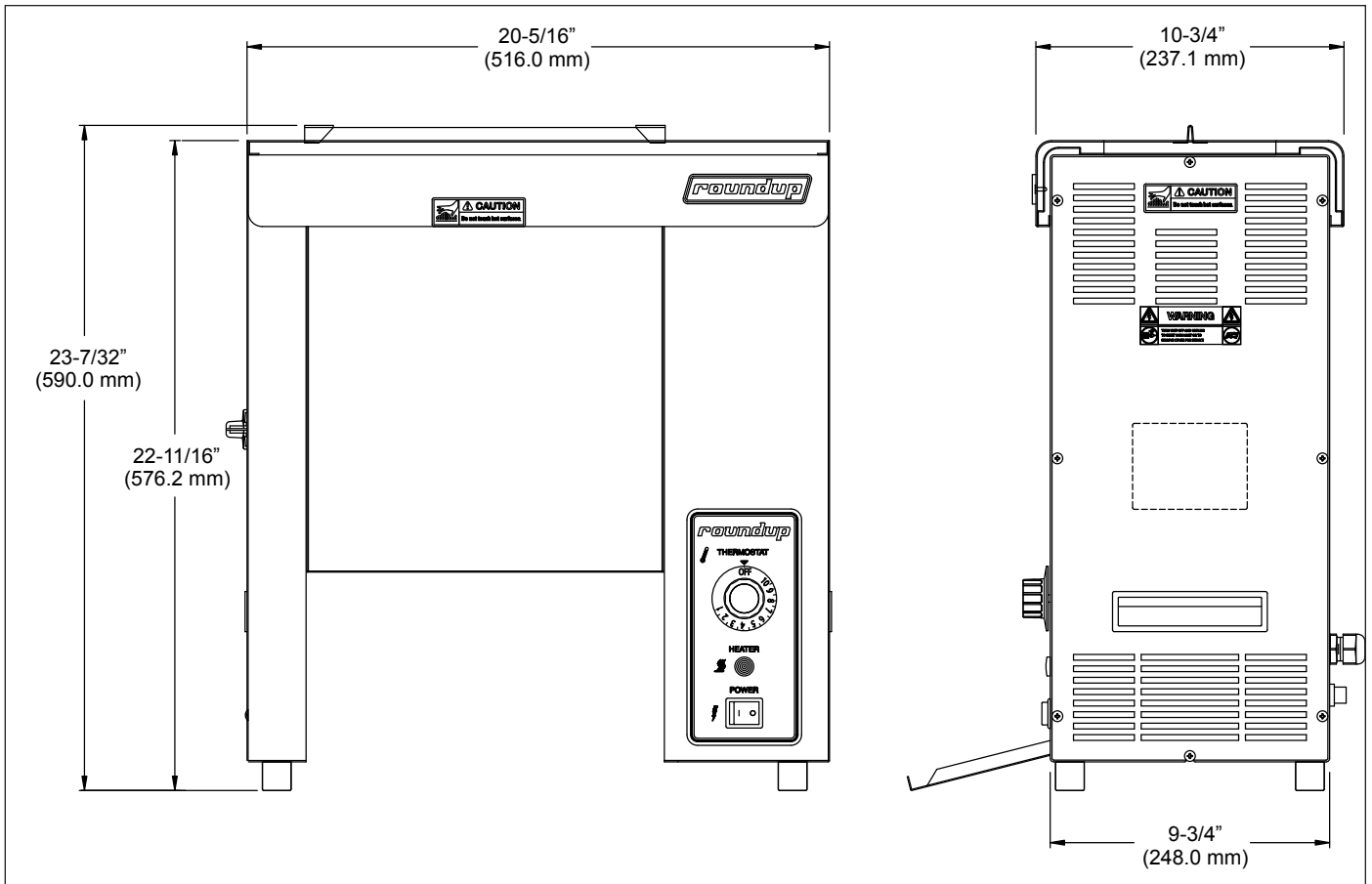

Model & Mfg. No.	Volts	Watts	Amp.	Hertz	Description
VCT-1000CF 9210700 9210706 9210716 9210722	120	1800	15.0	60	5-15P, 15 Amp., 120 VAC, Non-locking (Assembly Only)
VCT-1000CV 9210702 9210708 9210709 9210714 9210720 9210727	208/240	2600/3455	12.5/14.4	60	6-20P, 20 Amp., 250 VAC, Non-locking (Assembly Only)
VCT-1000HI 9210704 9210705 9210707 9210710 9210711 9210713	208/240	2600/3455	12.5/14.4	50	IEC-309, 16 Amp., 250 VAC, Pin & Sleeve (Assembly Only)

# INSTALLATION

## Unpacking

1. Remove unit and all packing materials from shipping carton.
2. Open the large box. It should contain:
  - Bun Feeder (Figure 1)
  - Bun Chute (Figure 2)
  - Two Release Sheets (Figure 1)
  - Authorized Service Agency Directory
  - Owner's Manual
3. Remove all packing materials and protective coverings from the unit and parts.

**NOTE:** If any parts are missing or damaged, contact Antunes Customer Service IMMEDIATELY at +1-877-392-7856 (toll free).

## Assembling the Unit

**NOTE:** The factory has pre-installed a Release Sheet over the Platen (Figure 1). Verify that it is properly in place before proceeding.

**CAUTION**

Failure to use Release Sheets may result in damage to the unit and loss of warranty coverage.

1. Install the Bun Feeder (Figure 1) and Bun Chute (Figure 2).

**NOTE:** As of March 2017, the Interlock Switch was removed from use. If your toaster has the Interlock Switch (Figure 11), you will need to place the Heat Shield onto the toaster in order for the conveyors to turn. If your toaster does not have an Interlock Switch, the conveyors will turn as long as the unit is on.

**NOTE:** Check the Release Sheet to make sure it is not caught in the conveyor. Additional Release Sheets can be purchased through your Authorized Service Agency under P/N 7000249 (3-pack) or 7000250 (10-pack).

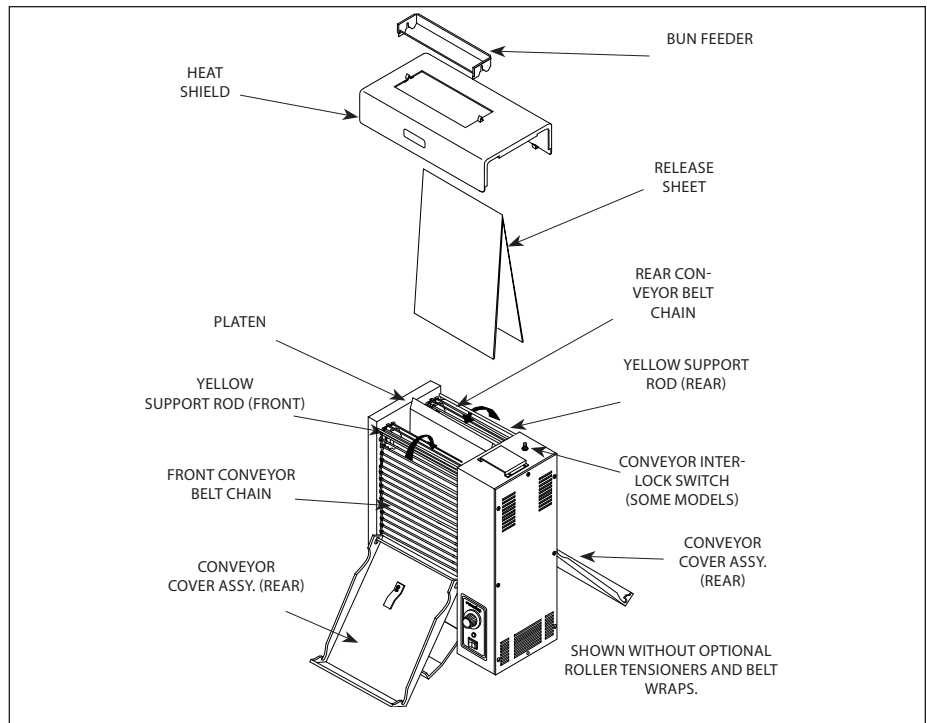

Figure 1. Toaster and Accessories

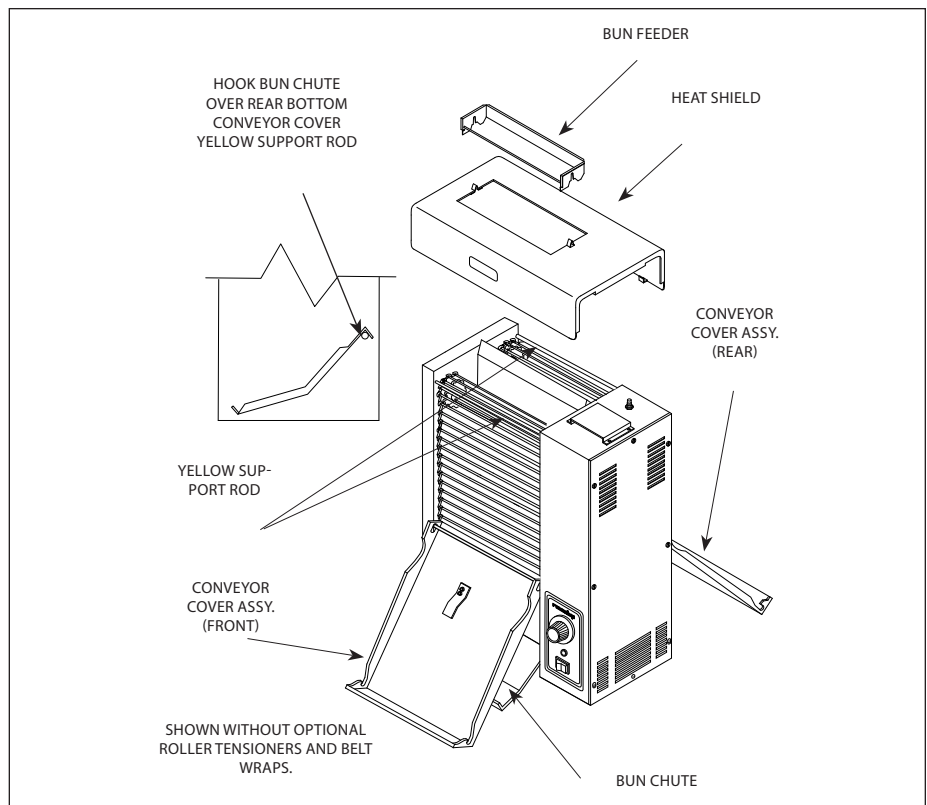

Figure 2. Installing Bun Chute

## Equipment Setup

When placing the toaster into service, pay attention to the following guidelines.

- Make sure power to the unit is off and the toaster is at room temperature.
- Do NOT block or cover any openings on the unit.
- Do NOT immerse cord or plug in water.
- Keep cord away from heated surfaces.
- Do NOT allow cord to hang over edge of table or counter.
- Connect the unit to the power supply. Refer to the specification plate for the proper voltage.

### WARNING

**ELECTRICAL SHOCK HAZARD.** Failure to follow the instructions in this manual could result in serious injury or death.

- Electrical ground is required on this appliance.
- Do NOT modify the power supply cord plug. If it does not fit the outlet, have a proper outlet installed by a qualified electrician.
- Do NOT use an extension cord with this appliance.
- The toaster should be grounded according to local electrical codes to prevent the possibility of electrical shock. It requires a grounded receptacle with separate electrical lines, protected by fuses or circuit breaker of the proper rating.
- Check with a qualified electrician if you are unsure if the appliance is properly grounded.

### CAUTION

All electrical connections must be in accordance with local electrical codes and any other applicable codes.

### CAUTION

Bread may burn. Therefore toasters must not be used near or below curtains or other combustible walls and materials. Failure to maintain safe operating distances may cause discoloration or combustion.

## OPERATING INSTRUCTIONS

1. Set the Bun Thickness Compression Knobs (Figure 7) to the desired settings.

**NOTE:** After initial run of 4-6 buns, adjust controls according to the desired finished product.

2. Turn the power on (Figure 6).
3. Turn the temperature control to 10 and allow the unit to warm up for 30 minutes.

4. Drop buns into toaster. Cut sides of heel and crown must face each other.
5. Toasted product will drop into the bun landing area (Figure 6).
6. Test at least 4 buns before putting toaster into service. Turn temperature control to lower setting for lighter toasting or to higher setting for darker toasting.
7. Turn the power off when finished toasting and follow the daily cleaning procedures.

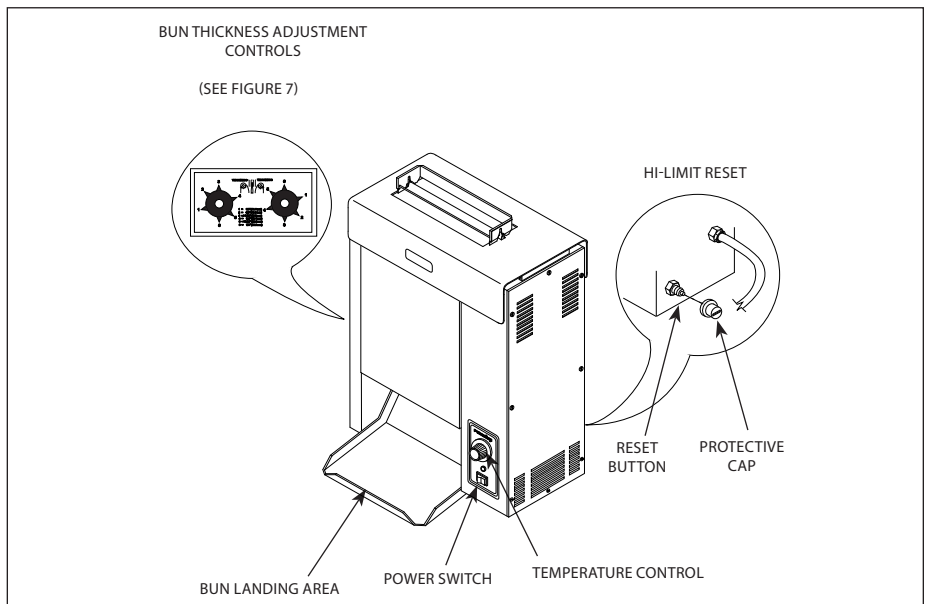

Figure 6. Toaster Controls

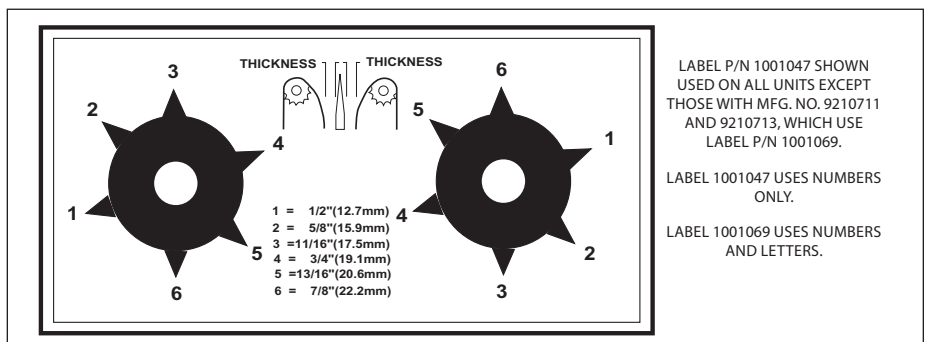

Figure 7. Bun Thickness Compression Knobs

## SAFETY FEATURES

### Hi-Limit Reset Button

A Hi-Limit Control turns off electrical power to the heater if the unit overheats. To reset this control, allow 10-15 minutes for the unit to cool down, Remove the Protective Cap, and fully press the Reset Button located at the rear of the unit (Figure 6).

If the unit requires continuous resetting, contact your Authorized Service Agency.

## MAINTENANCE

### Daily

#### CAUTION

Turn the power off, disconnect the power cord, and allow the unit to cool down 30 minutes before performing any service or maintenance.

#### CAUTION

To prevent damage to the unit, do not use abrasive cleaners on the Release Sheet or belt wrap.

#### CAUTION

Failure to use Release Sheets may result in damage to the unit and loss of warranty coverage.

#### Tools Required:

- Heat-Resistant Gloves
  - Clean Towels
  - Multipurpose Detergent Solution
  - Sanitizer Solution
1. Turn the power off, unplug the power cord, and allow the unit to cool for 30 minutes.
  2. Put on heat resistant gloves. Remove the Bun Feeder, Heat Shield, and Bun Chute (Figure 1).
  3. Wipe the Bun Feeder, Heat Shield, and Bun Chute with a damp sanitized towel and allow them to air dry.
  4. Remove the Release Sheet and place it on a clean, flat dry surface.
  5. Wipe the silver side with a clean towel dampened with Multipurpose Detergent Solution immediately followed by a second clean towel dampened with sanitizer. Allow it to air dry before continuing.
  6. Once the silver side of the Release Sheet is dry, repeat Step 5 on the black side. If properly cleaned, the Release Sheet surface should be smooth to the touch when dry.
  7. Open the front Conveyor Cover and firmly wipe the Belt Wrap (if used) or Conveyor Belt Chain from left to right and top to bottom with a clean towel dampened with Multipurpose Detergent Solution immediately followed by a second clean towel dampened with sanitizer solution.

8. Close the front Conveyor Cover, open the rear Conveyor Cover, and clean the Belt Wrap (if used) or Conveyor Belt Chain as described in Step 7.
9. Close the rear Conveyor Cover and reinstall the Heat Shield. Then plug in the power cord, turn the unit on, count 10 seconds, then turn the unit off and unplug the unit. This will allow the uncleaned sections to be exposed.

**NOTE:** As of March 2017, the Interlock Switch was removed from use. If your toaster has the Interlock Switch (Figure 11), you will need to place the Heat Shield onto the toaster in order for the conveyors to turn. If your toaster does not have an Interlock Switch, the conveyors will turn as long as the unit is on.

10. Open the rear Conveyor Cover again, clean the newly exposed section of the Belt Wrap (if used) or the Conveyor Belt Chain in the same manner as before. Close the Conveyor Cover.
11. Open the front Conveyor Cover again and clean the newly exposed section of the Belt Wrap (if used) or Conveyor Belt Chain in the same manner as before.
12. Close the front Conveyor Cover and wipe down the outside of the toaster with a clean, damp, sanitized towel.
13. Install a new or clean Release Sheet, using the reverse side, by draping it over both sides of the Platen with the crease centered on the Platen.
14. Install the Bun Chute so the hooks are installed over the lower rear yellow Support Rod.
15. Install the Heat Shield with the Release Sheet retainer clips securely over the Release Sheet and Platen.
16. Reinstall the Bun Feeder and plug in the unit.

**NOTE:** Additional Release Sheets can be purchased through your Authorized Service Agency under P/N 7000249 (3-Pack) or 7000250 (10-Pack).

### Replacing the Black and Silver Release Sheet (Every 4–6 weeks)

**NOTE:** Depending on toaster usage and on how well it is cleaned daily, the Release Sheet should last between 45–60 days.

1. Remove and discard the Release Sheet.
2. Lay a new Release Sheet on a clean, dry surface and fold it in half lengthwise and gently crease it at the fold using only your fingers (Figure 8).
3. Install the Release Sheet just as you would after Daily Cleaning.

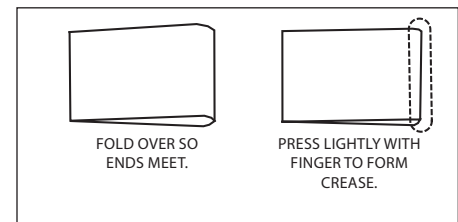
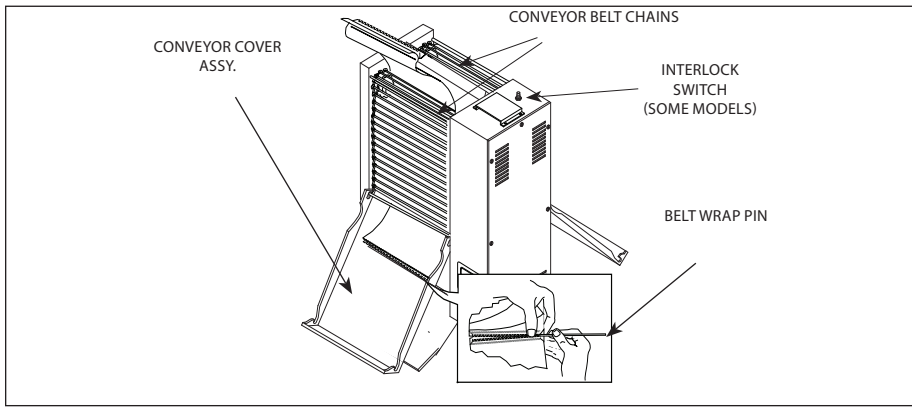

Figure 8. Folding the Release Sheet

### Replacing the Optional Belt Wraps (Every 3–6 months)

**NOTE:** Depending on toaster usage and how well they are cleaned daily, the Belt Wraps should last between 3–6 months. Additional Belt Wraps may be purchased from your Authorized Service Agency.

1. Turn unit off, unplug the power cord, and allow the unit to cool before proceeding.
2. Remove the Bun Feeder and Heat Shield and set the Bun Thickness Compression Knobs to 6 & 6 or 6 & F.
3. Open both Conveyor Covers and pull the Belt Wrap Pin out of the zipper (Figure 9).
4. Remove and discard the old Belt Wrap(s).
5. Clean both Conveyor Belt Chains just as you would clean the Belt Wraps during daily cleaning.
6. Install the new Belt Wrap(s) around the Conveyor Belt Chains inside the yellow rods with the zipper flap exposed and hanging down (Figures 10 & 11).
7. Close the Conveyor Cover(s), set the Bun Thickness Compression Knobs back to their normal settings and reinstall the Heat Shield and Bun Feeder.



**Figure 9. Removing Optional Belt Wrap**

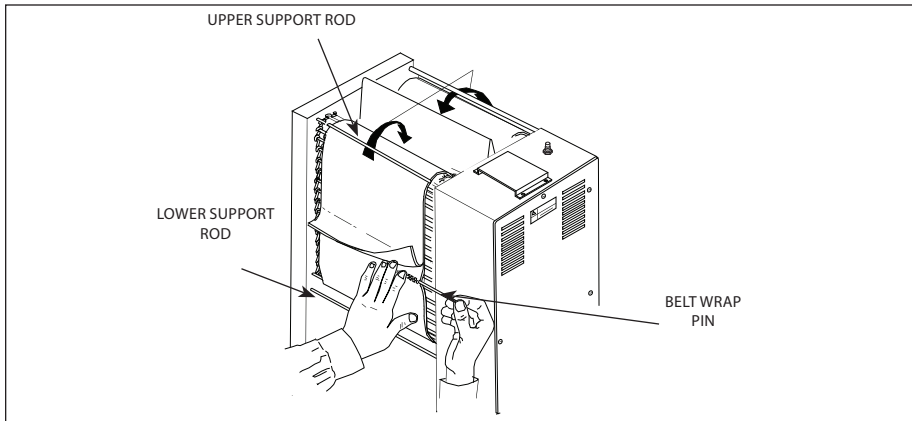

**Figure 10. Installing Belt Wrap**

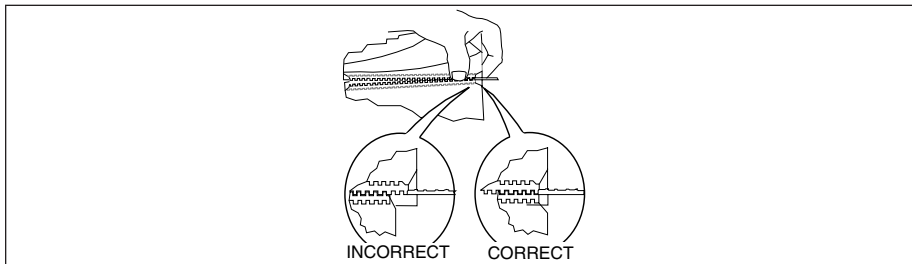

**Figure 11. Aligning Belt Teeth**

**CAUTION**

Align the ends of the Belt Wrap properly (Figure 11) or the Belt Wrap may be damaged.

**CAUTION**

Position the Belt Wrap inside the upper and lower yellow support rods or damage to the unit may occur.

**Checking the Conveyor Belt Chains**

**NOTE:** The Bun Thickness Compression Knobs (Figure 7) must be set to "6 & 6" or "6 & F" prior to measuring or removing or reinstalling the Conveyor Belt Chains.

**Measuring conveyor belt Chains**

1. Turn the unit off, unplug the power cord, and allow the unit to cool.
2. Remove the Bun Feeder, Butter Wheel, Pan, and Heat Shield (Figure 1) and set the Bun Thickness Compression Knobs to 6 & 6 or 6 & F.
3. Open both Conveyor Covers and pull the Belt Wrap Pin out of the zipper (Figure 9).
4. Remove the Belt Wrap.
5. Facing the toaster, locate the approximate center-point of the Conveyor Chain.
6. Pull the Conveyor Chain away from the edge of the toaster (Figure 12).
7. Stand a U.S. Dime on end between the frame and the chain (Figure 12).
8. If the gap is significantly wider than the coin, REMOVE links as described below.
9. Disconnect the Conveyor Belt Chain by squeezing any two links together and unhooking both ends one link (Figure 13). Needle-nose pliers may be used.

**NOTE:** There are two small 1/2" links on each side of the Conveyor Belt Chain. The rest are large 3/4" links.

10. Remove one 1/2" link from the belt.
11. Reassemble the Conveyor Belt Chain onto the sprockets as described in Replacing Conveyor Belt Chains.
12. Measure the gap again to ensure it is not too tight.
13. Check the opposite side of the toaster using the same steps.

**NOTE:** If the Conveyor Belt Chain is too tight to be reassembled, remove an additional small 1/2" link and install a large 3/4" link in its place. This will shorten the Conveyor Belt Chain by 1/4" overall.



## Replacing conveyor belt Chains

1. Turn the power off, unplug the power cord, and allow the unit to cool before proceeding.
2. Remove the Butter Wheel, Pan, and Heat Shield and set the Compression Control Knobs to 6 & 6 or 6 & F.
3. Open both Conveyor Covers and pull the Belt Wrap Pin out of the zipper.
4. Remove & discard old Belt Wrap(s).
5. Disconnect the Conveyor Belt Chain by squeezing any two links together and unhooking both ends of one link (Figure 13).
6. Place the replacement Conveyor Belt Chain on the top sprockets with hook ends down.

**NOTE:** The ends of the hooks must point down (Figure 13).

7. Wrap the Conveyor Belt Chain around the top and lower sprockets and connect by hooking both ends together.

**NOTE:** Make sure the Conveyor Belt Chain is installed under the Upper Support Rod and over the Lower Support Rod.

## Checking the Roller Tensioners (every 3–6 months)

### Measuring The Roller Tensioners

1. Measure the Roller Tensioner on both inner Conveyor Covers (Figure 14) using a U.S. Nickel.
2. The space between the inner Conveyor Cover and bottom of the Tensioner wheel should be  $13/16$ " (2.1 cm) or the height of a U.S. Nickel.
3. Adjust or replace any damaged ones as recommended.

### Replacing Roller Tensioners

1. Push down on retaining tab of the tensioner.
2. While keeping pressure on the retaining tab, slide the tensioner out of the retainer plate.
3. Replace the tensioner by sliding the new one into the retainer plate.

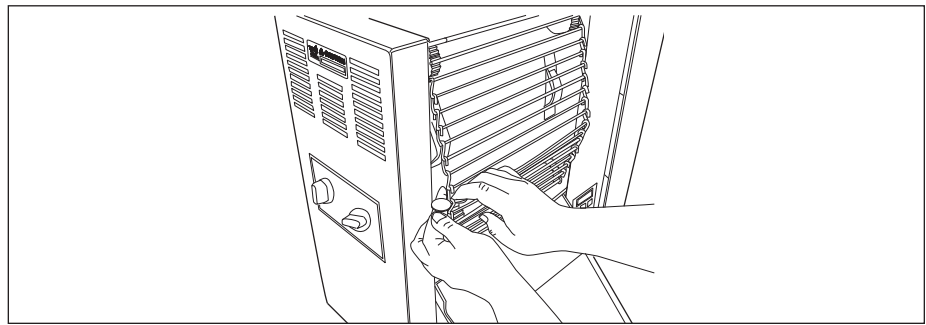

Figure 12. Removing Conveyor Belt Chain

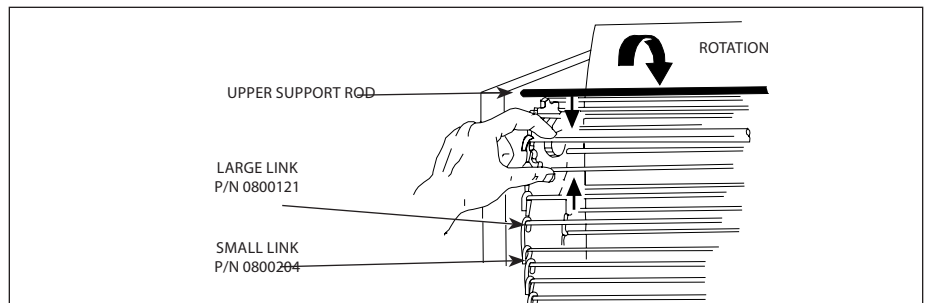

Figure 13. Removing Conveyor Belt Chain

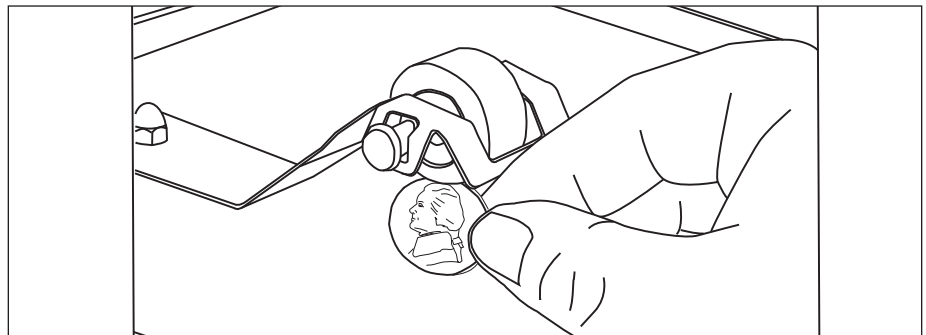

Figure 14. Measuring Roller Tensioner

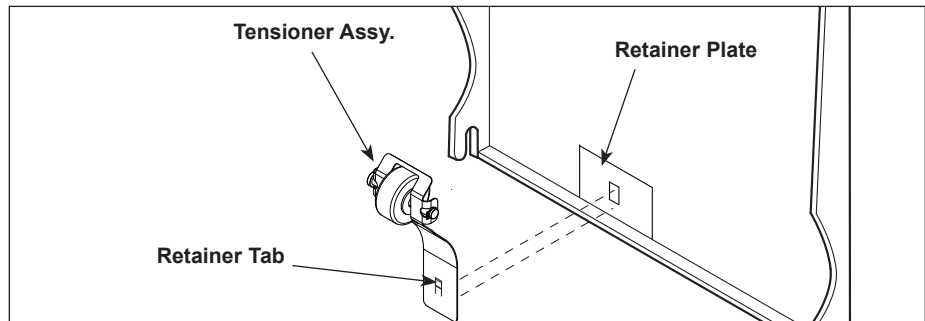

Figure 15. Replacing Roller Tensioner Assy.

# TROUBLESHOOTING

## WARNING

**To avoid possible personal injury and/or damage to the unit, inspection, test and repair of electrical equipment should be performed by qualified service personnel. The unit should be unplugged when servicing, except when electrical tests are required. Use extreme care during electrical circuit tests. Live circuits will be exposed.**

Problem	Possible Cause	Corrective Action
No heat and Conveyor Belt Chains do not move.	Toaster is installed incorrectly.	Perform the installation and operating procedures found in the Installation and Operation sections of this manual.
	Inoperable Power Cord or Power Switch.	Check receptacle for correct voltage (see the Specifications section of this manual).  If necessary, contact your maintenance person or Authorized Service Agency for service.
	Hi-Limit Control is tripped.	Reset the Hi-Limit Control (see Figure 6 in the Operations section of this manual).
	Wiring problem.	Contact your maintenance person or Authorized Service Agency for service.
No heat but Conveyor Belt Chains move.	Wiring problem.	Contact your maintenance person or Authorized Service Agency for service.
	Inoperative Platen.	
	Inoperable Thermostat	
Platen is hot but Conveyor Belt Chains do not rotate.	Heat Shield not installed.	Install Heat Shield (Figure 2).
	Conveyor Safety Interlock Switch (if present) not activated by the Heat Shield.	Re-install the Heat Shield correctly so that the Heat Shield applies appropriate pressure on the Conveyor Safety Interlock Switch. If the Interlock Switch has failed, order kit 7001436 to remove and bypass the Interlock Switch.
	Spring Tensioner Assembly or Roller Tensioner is damaged or missing.	Replace Spring Tensioner or Roller Tensioners if damaged or missing.
	Conveyor Belt Chain links too loose.	Adjust Conveyor Belt Chain length as described in the Maintenance section of this manual.
	Inoperable Drive Motor.	Contact your maintenance person or Authorized Service Agency.
	Loose Drive Motor Sprocket Setscrew.	
	Drive Motor Chain has fallen off sprocket(s).	
	Inoperable Safety Interlock Switch.	
Conveyor Belts Chains hesitate to rotate and/or skip on sprockets.	Conveyor Belt Chains installed incorrectly.	Install Conveyor Belt Chains to match Figure 11. Be sure that the ends of the hooks are facing down.
	Conveyor Belt Chains too loose.	Adjust Conveyor Belt Chain length as described in the Maintenance section of this manual.
	Spring Tensioner Assembly or Roller Tensioner is damaged or missing.	Replace Spring Tensioner Assembly or Roller Tensioners if damaged or missing.

<b>Problem</b>	<b>Possible Cause</b>	<b>Corrective Action</b>
Product is over toasted, Platen heat is too high, or drop time is too slow.	Temperature set too high.	Set temperature control to a lower setting.
	Bun Thickness Compression Knobs set improperly.	Measure bun thickness and set Bun Thickness Compression Knobs correctly (Figure 7).
	Buns sticking on Release Sheet.	Clean or replace Release Sheet according to the procedure in the Maintenance section of this manual.
	Conveyor Cover Assembly not installed properly.	Re-install Conveyor Cover Assembly.
	Loose sprocket setscrews.	Check drive chain for kinks, broken or bent links, or other damage. Check motor sprocket and drive sprockets; tighten setscrew on flat of shaft if required. Check for damaged/worn sprocket and replace as required.
	Conveyor Belt Chain too loose.	Adjust Conveyor Belt Chain length as described in the Maintenance section of this manual.
Product is under toasted, Platen heat is too low, or drop time is too fast.	Spring Tensioner Assembly or Roller Tensioner is damaged or missing.	Replace Spring Tensioner Assembly or Roller Tensioner if damaged or missing.
	Bun Thickness Compression Knobs set improperly.	Measure bun thickness and set Bun Thickness Compression Knobs correctly (Figure 7).
	Wiring problem.	Contact your maintenance person or Authorized Service Agency for service.
	Inoperable Thermostat.	
Product is getting stuck or Conveyor Belt Chains stop when product is toasting.	Conveyor Drive Motor inoperable or incorrect conveyor motor installed in toaster.	
	Bun Thickness Compression Knobs Set improperly.	Measure bun thickness and set Bun Thickness Compression Knobs correctly.
	Release Sheet not cleaned properly or is missing.	Clean or replace Release Sheet as described in the Maintenance section of this manual..
	Conveyor Drive motor inoperative or incorrect conveyor motor installed in toaster.	Contact your maintenance person or Authorized Service Agency for service.
	Conveyor Drive Chain loose, worn, or broken. Loose motor drive sprocket.	Check drive chain for kinks, broken or bent links, or other damage. Check motor sprocket and drive sprockets, tighten setscrew on flat of shaft if required. Check for damaged/worn sprockets and replace as required.
	Conveyor Belt Chain too loose.	Adjust Conveyor Belt Chain length as described in the Maintenance section of this manual.
Spring Tensioner Assembly or Roller Tensioner is damaged or missing.	Replace Spring Tensioner Assembly or Roller Tensioner if damaged or missing.	

# WIRING DIAGRAM

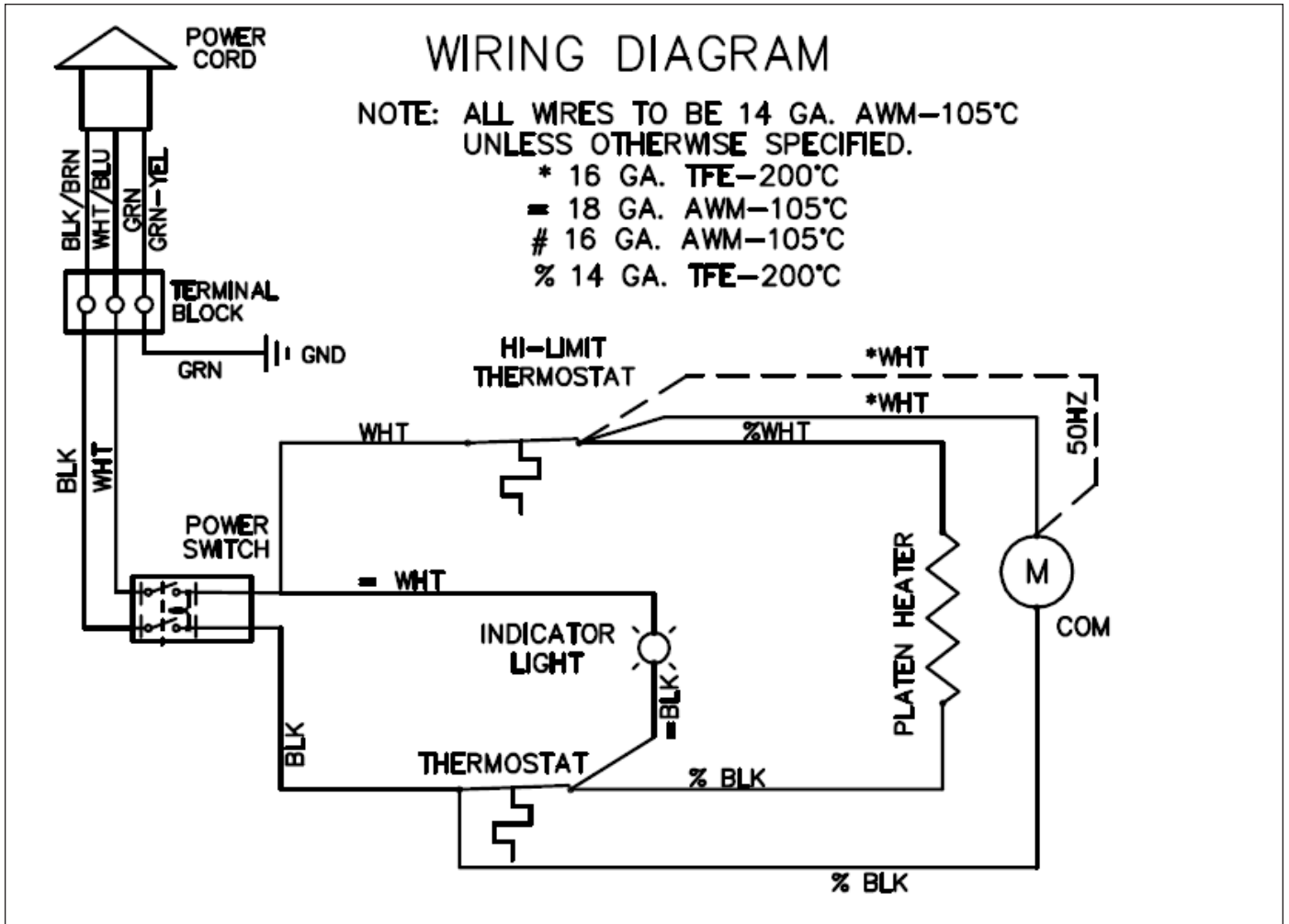

# REPLACEMENT PARTS

## Parts Identification

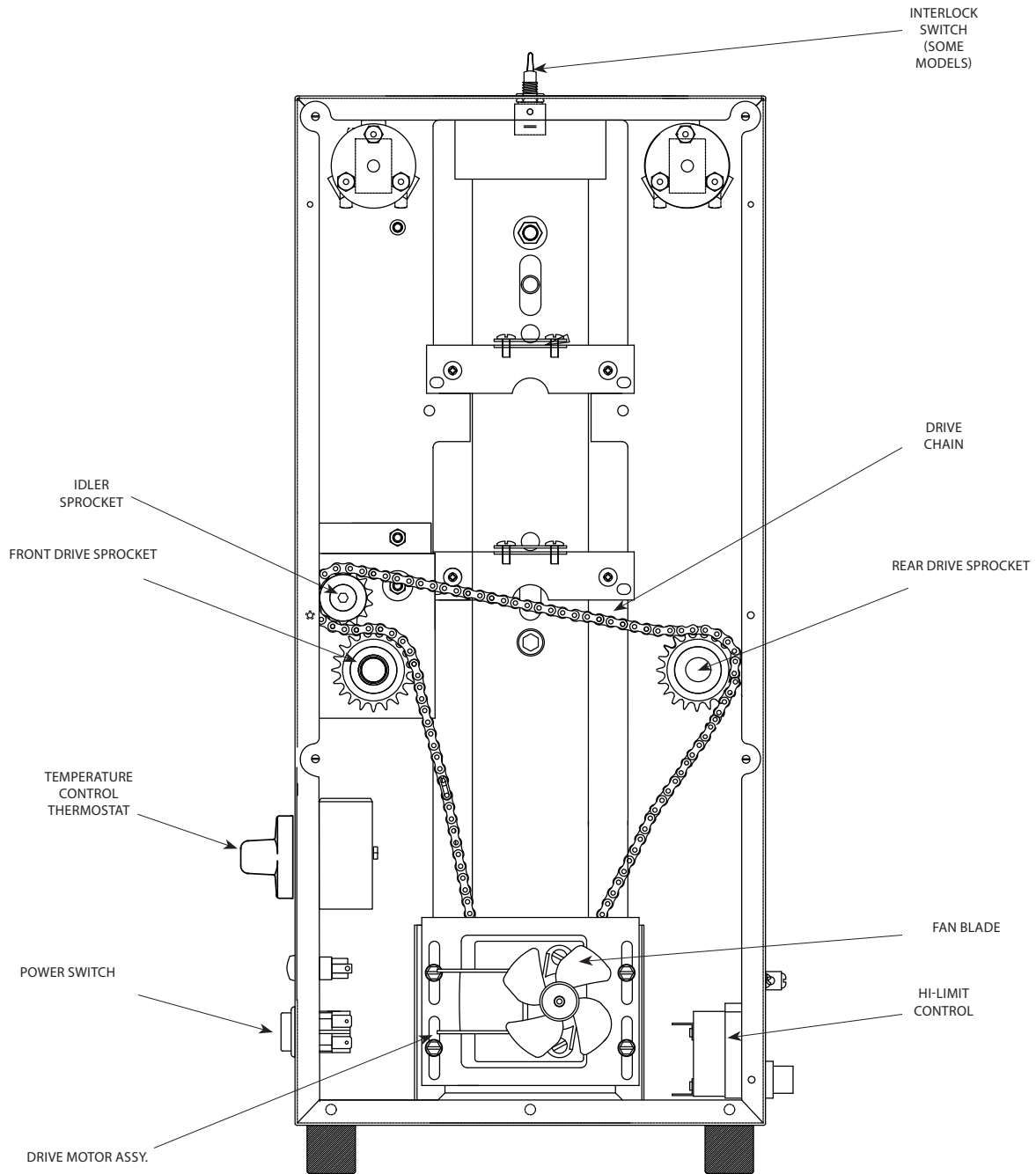

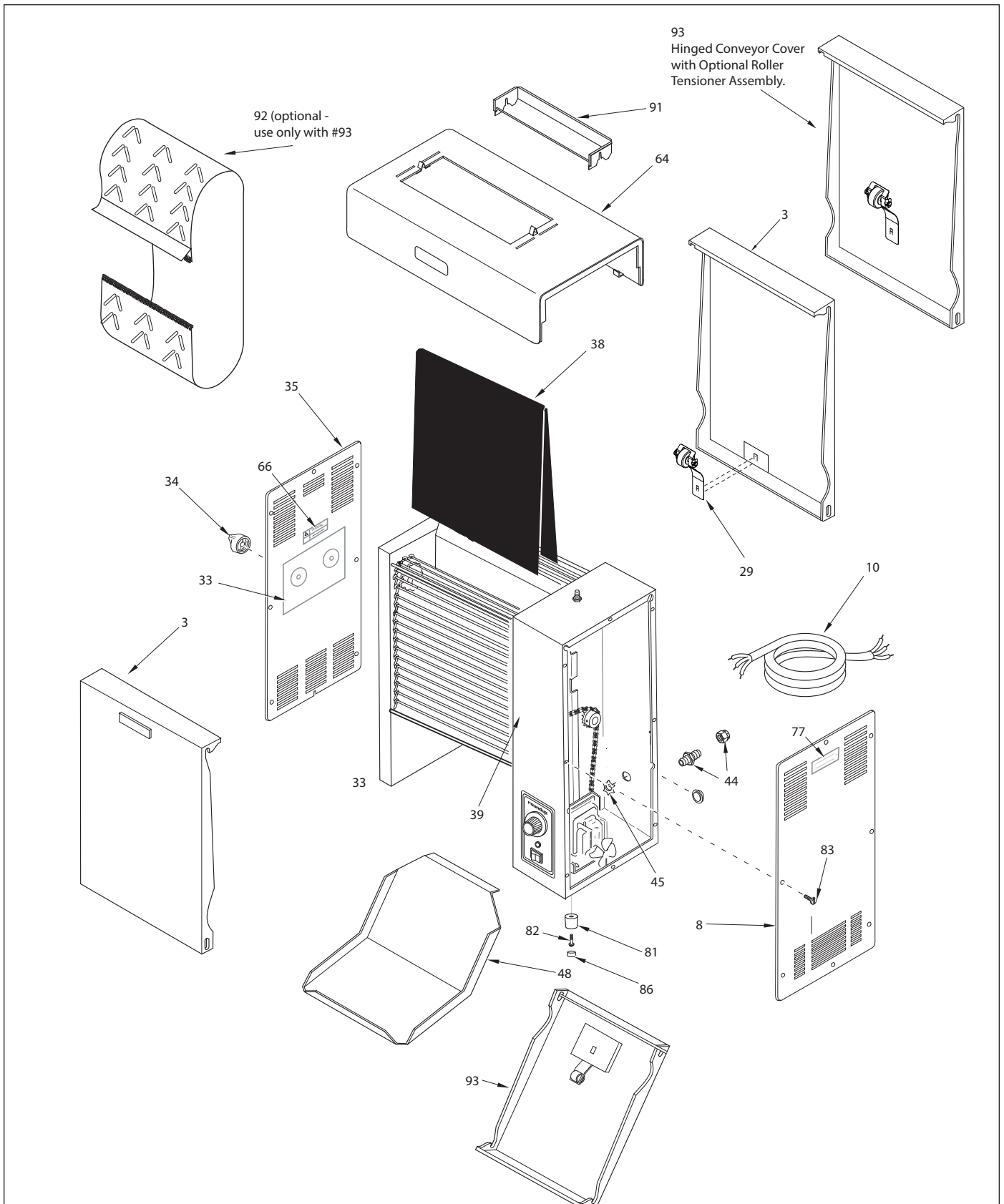

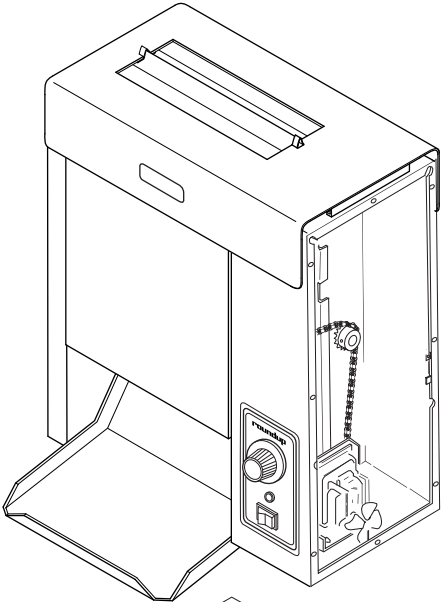

**NOTE: As of March 2017, the Interlock Switch (item 53) is discontinued from use. If your toaster has the Interlock Switch and it fails, order kit 7001436 to remove and bypass the Interlock Switch.**

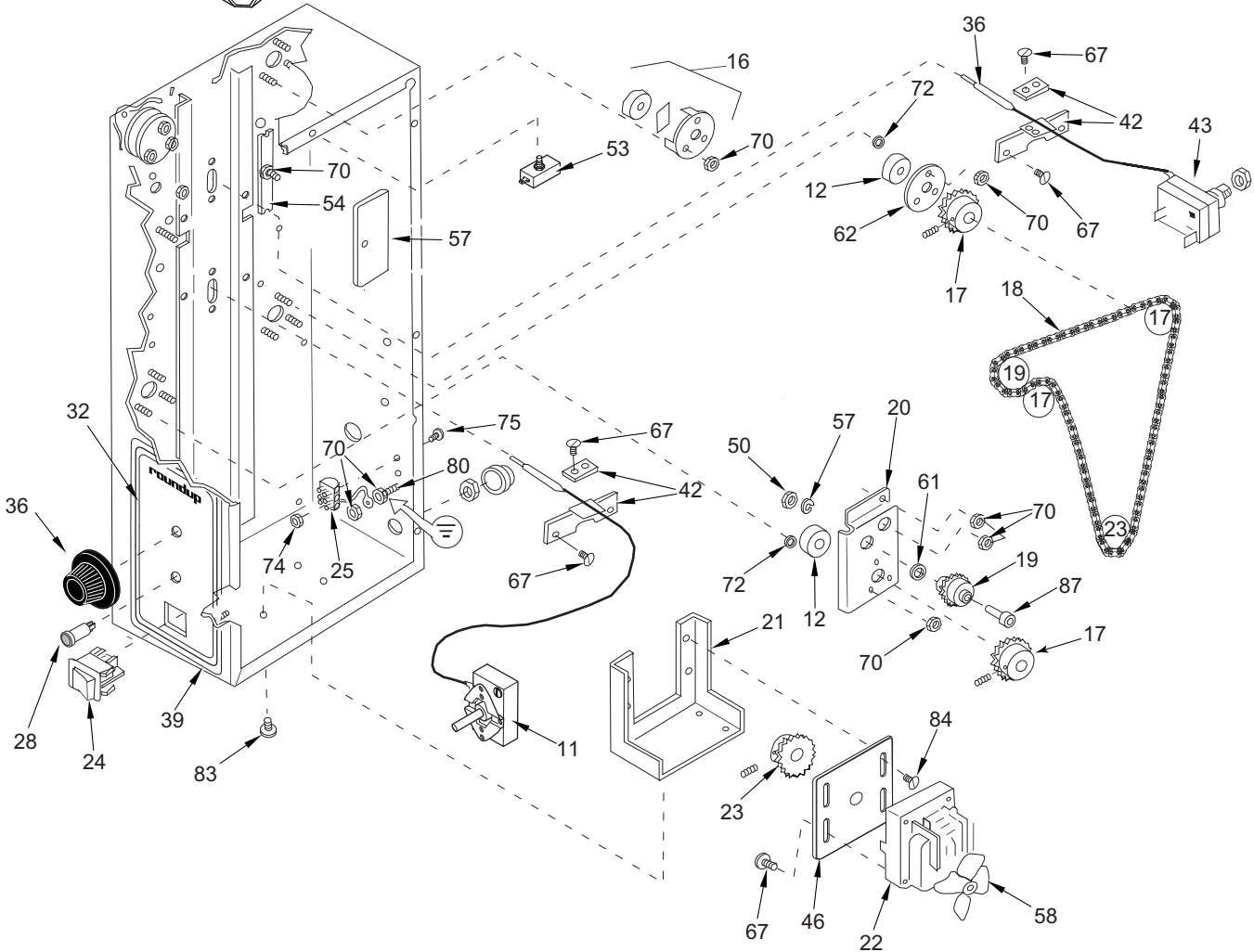

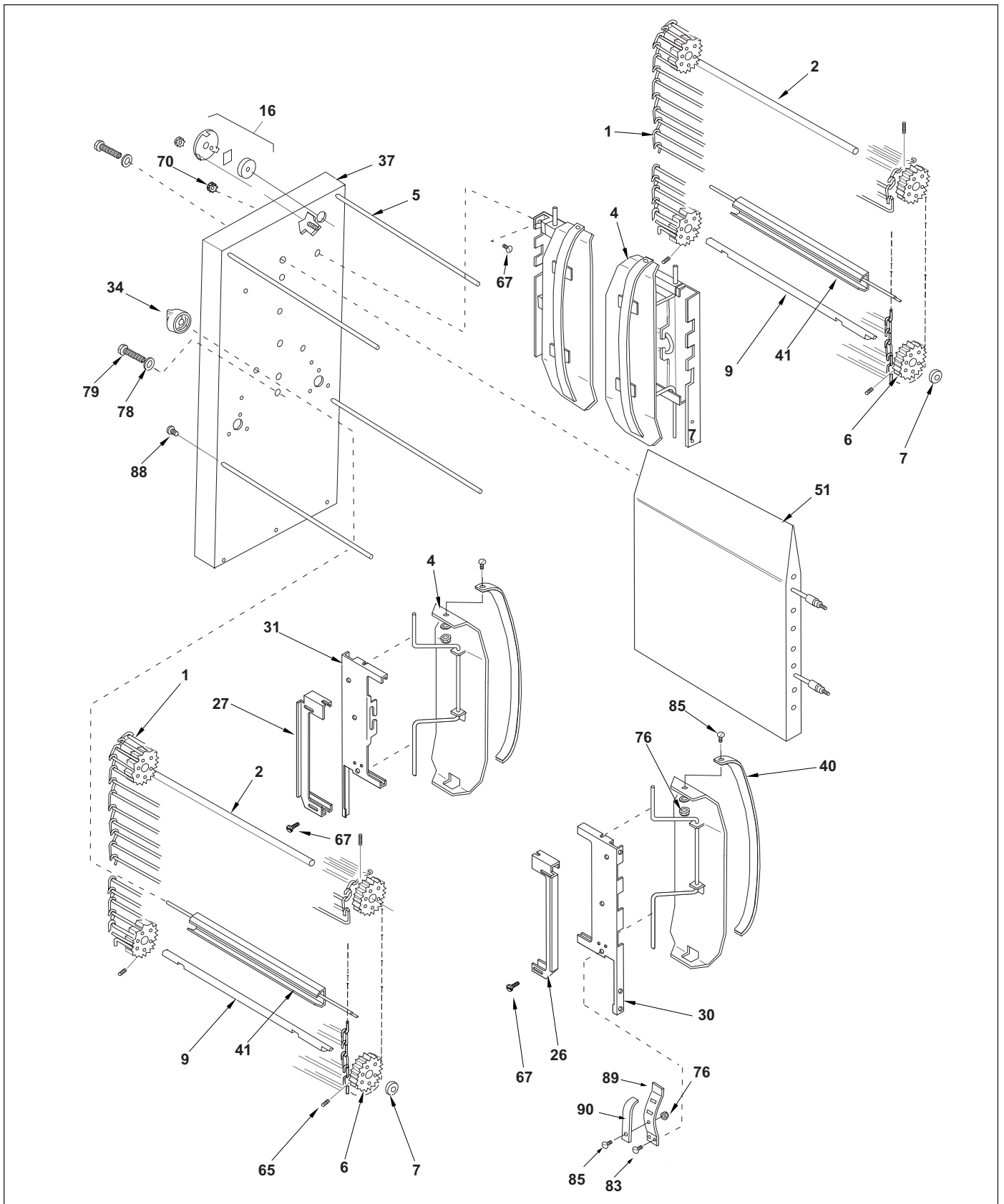



Item Part No.	Description	Qty.
1	0011266 Conveyor Belt (Incl. Items Below)	2
	0800204 1/2" Pitch Link, Small	2
	0800121 3/4" Pitch Link, Large	38
2	2150117 Idler Shaft	2
3	0011609 Conveyor Cover Assy. (Incl. #95)	2
4	0010475 Tensioner Assy. (Incl. #40, 76, 85)	4
5	0800332 Rod, Conveyor Cover	4
6	7000207 Sprocket (Incl. #65)	8
7	7000199* Spacer Kit	2
8	0011444 Control Cover	1
9	2150118 Drive Shaft	2
10	0700452 Power Cord/Plug, NEMA 6-20P	1
	0700463 Power Cord/Plug, NEMA 5-15P	1
	0700437 Power Cord/Plug, IEC-309	1
	0700453 Power Cord/Plug, CEE 7/7	1
11	4030355 Thermostat, 600°F	1
12	7000296 Ball Bearing (Pack of 2)	1
16	7000167 Bearing & Retainer Kit	6
16A	7000224 Bearing & Retainer Kit (Incl. Six of #16)	1
17	2150181 Drive Sprocket	2
	2150109 Drive Sprocket (Mfg. No. 9210705 only)	2
18	2150187 Drive Chain	1
	2150215 Drive Chain (for Mfg. #9210714 & 720)	1
19	0011299 Idler Sprocket & Bearing	1
20	0011300 Bracket, Idler Sprocket (Incl. #50, 57, 61, 19, & 87)	1
21	0503589 Bracket, Motor Mounting	1
22	7000240 Drive Motor Kit 230V (Incl. #58)	1
	7000282 Drive Motor Kit 120V (Incl. #58)	1
	7000271 Drive Motor Kit 230V (for Mfg. #9210714 & 720)	1
	0012112 Gearmotor Assy 230V 3 RPM (for Mfg. #9210705)	1
	0011390 Drive Motor Assy - 230V/9RMP	1
23	2150199 Sprocket, Motor (Mfg. #9210700, 702, 706, & 708)	2
	2150211 Sprocket, Motor (Mfg. #9210704, 710 & 9210712)	2
	2150112 Sprocket, Motor (for Mfg #9210714 & 720)	2
	2150173 Sprocket, Motor (Mfg. No. 9210716 & 722)	2
	2150193 Sprocket, 25B24 1/2" Bore (Front) (Mfg. No. 9210711)	1

Item Part No.	Description	Qty.
24	4010245 Rocker Switch, On/Off	1
25	4060355 Terminal Block	1
26	0503495 Retainer, Tension Bracket, RH	2
27	0503507 Retainer, Tension Bracket, LH	2
28	4060229 Indicator Light, Amber (250V)	1
	4060323 Indicator Light, Amber (125V)	1
29	0013373 Roller Tensioner Assy.	2
30	0503496 Tensioner Bracket, Right	2
31	0503497 Tensioner Bracket, Left	2
32	1000899 Label, Control	1
33	10P1047* Label, Dial (Pack of 10) All units except Mfg. No. 9210711 & 9210713	1
	10P1069* Label, Dial (Pack of 10) Mfg. No. 9210711 & 9210713 only.	1
34	2100253 Knob, Cam	2
35	0011445 Cover, End Housing	1
36	2100133 Knob, Thermostat Control	1
37	0021170 Weldment, End Housing	1
38	7000249 Release Sheet (Pack of 3)	-
	7000250 Release Sheet (Pack of 10)	-
39	0021194 Weldment, Control Housing	1
40	7000121 Slide Rail Kit (Incl. Two Slide Rails for Tensioners)	2
41	0021207 Conveyor Cam	2
42	7000176 Thermocouple Retainer Kit	2
43	4030332 High Limit Control	1
44	0400251 Strain Relief	1
	0400315 Strain Relief (Mfg # 9210704 only)	1
45	0400138 Locknut, 1/2"	1
46	0503590 Bracket, Motor	1
48	0503385 Bun Chute	1
50	331P101* Nut, Hex, 5/16 x 18"	1
51	7000200 Platen, 208V	1
	7000229 Platen, 120V	1
	7000289 Platen, 230V (Mfg. #9210712)	1
53	4010107 Interlock Switch (some models)	1
57	0503608 Cover Plate	2
58	4000170 Fan Blade, Motor	1
59	2100256 Tape, Hi-Temp	4
61	212P118* Flat Washer, 5/16"	1
62	0500464 Retainer, Bearing	1
64	0011528 Heat Shield Assy.	1
	7000707 Heat Shield with Dampers (9210713 Only)	1
65	325P163 Setscrew, 1/4-28 x 5/16"	8
66	100P864* Label, Caution Hot	1
67	308P154* Screw, #10-32 x 3/8"	2
68	306P104* Screw, #6-32 x 1/4"	8
69	406P107* Cable Tie	1
70	308P143* Nut, #8-32, "KEPS"	6
71	310P103* Screw, #10-32 x 1/4"	4
72	310P140* Washer, #10	6
Item Part No.	Description	Qty.

73	308P101* Nut, #8-32	3
74	306P101* Nut, Hex, #6-32	2
75	306P123* Screw, #6-32 x 7/8"	2
76	308P145* Nut, Hex Acorn, #8-32	10
77	100P900* Label, Service	1
78	325P104* Washer, 1/4"	4
79	325P109* Screw, 1/4-20 x 1/2"	4
80	308P124* Screw, 1-Way, #8-32 x 1/2"	1
81	210P230 Bumper, Recess Leg, 1"	4
82	310P136* Screw, #10-32 x 1-1/4"	4
83	308P133* Screw, #8-32 x 1/4"	12
84	308P183* Screw, Hex Head, #8-32 x 3/8"	4
85	308P181* Screw, Flat Hd., #8-32 x 3/8"	4
86	218P145* Cover, Leg, Bumper	4
87	331P103* Shoulder Bolt, 5/16"-18	1
88	306P105* Screw, #6-32 x 1/2"	1
89	0503455 Tension Spring, Inner	4
90	2100259 Slide Bar	4
91	0011549 Bun Feeder	1
92	7000192 Belt Wrap (optional for Mfg. No. 9210716 722 & 727)	1
93	0011491 Conveyor Cover Assy. (Mfg. No. 9210706, 708, 710, 716, 722, & 727) (Incl. #94)	1

\* Only available in packages of 10.

**Mechanical Butter Wheel Kit (P/N 7000298) Requires Professional Installation.**

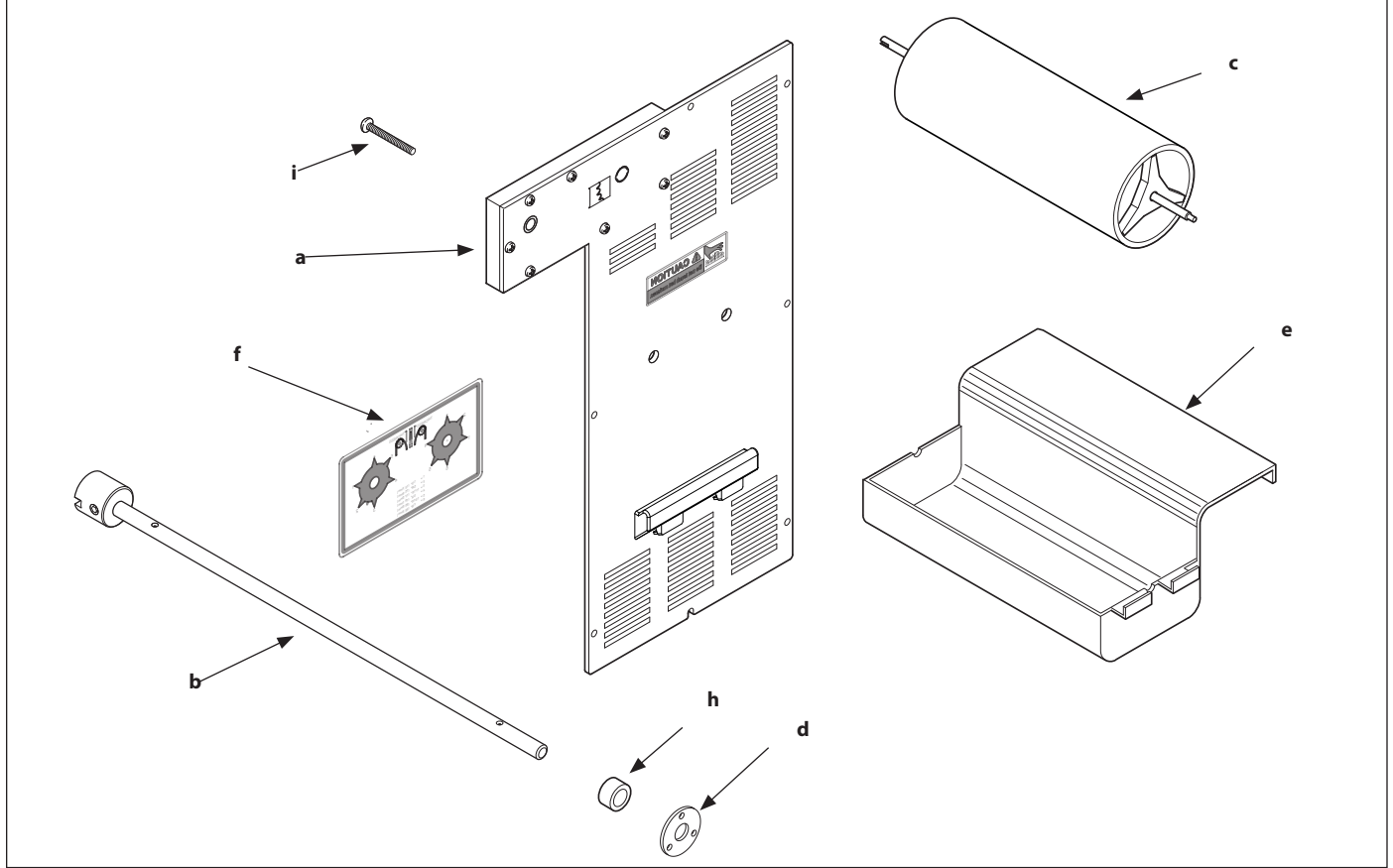

Item	Part No.	Description	Qty.
1	7000298	Butter Wheel Kit ( Includes Items Below)	
a	0011552	End Housing Cover Assy.	1
b	0011573	Idler Shaft Assembly	1
c	0021320	Roller Weldment	1
d	0500464	Retainer, Bearing	1
e	0503987	Pan, Butter	1
fa	1001047	Label, Dial Compression	1
g	1010773	Instruction Sheet (not shown)	1
h	2120107	Spacer, Aluminum	1
i	3080162	#8-32 x 1-1/4 Screw (not shown)	1

**Mechanical Butter Wheel Kit (model 7000238)**

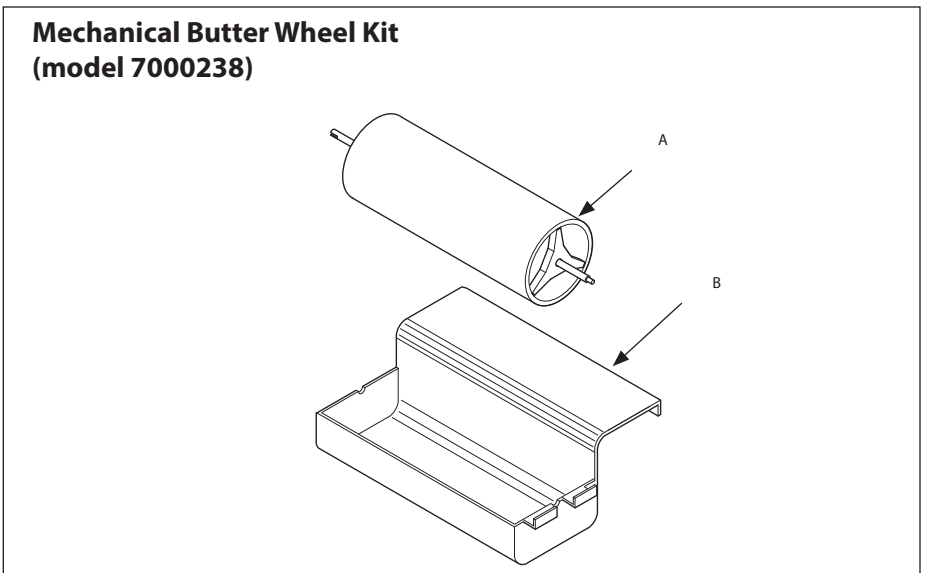

Item	Part No.	Description	Qty.
1	7000238	Butter Wheel Kit (Includes Items Below)	
a	0020205	Butter Roller Weldment	1
b	0021232	Butter Tray Weldment	1



## LIMITED WARRANTY

Equipment manufactured by Antunes(Antunes) has been constructed of the finest materials available and manufactured to high quality standards. These units are warranted to be free from electrical and mechanical defects for a period of one (1) year from date of purchase under normal use and service, and when installed in accordance with manufacturer's recommendations. To insure continued operation of the units, follow the maintenance procedures outlined in the Owner's Manual. During the first 12 months, electro-mechanical parts, non-overtime labor, and travel expenses up to 2 hours (100 miles/160 km), round trip from the nearest Authorized Service Center are covered.

1. This warranty does not cover cost of installation, defects caused by improper storage or handling prior to placing of the Equipment. This warranty does not cover overtime charges or work done by unauthorized service agencies or personnel. This warranty does not cover normal maintenance, calibration, or regular adjustments as specified in operating and maintenance instructions of this manual, and/or labor involved in moving adjacent objects to gain access to the equipment. This warranty does not cover consumable/wear items. This warranty does not cover damage to the Load Cell or Load Cell Assembly due to abuse, misuse, dropping of unit/shock loads or exceeding maximum weight capacity (4 lbs). This warranty does not cover water contamination problems such as foreign material in water lines or inside solenoid valves. It does not cover water pressure problems or failures resulting from improper/incorrect voltage supply. This warranty does not cover Travel Time & Mileage in excess of 2 hours (100 miles/160 km) round trip from the nearest authorized service agency.
2. Antunes reserves the right to make changes in design or add any improvements on any product. The right is always reserved to modify equipment because of factors beyond our control and government regulations. Changes to update equipment do not constitute a warranty charge.
3. If shipment is damaged in transit, the purchaser should make a claim directly upon the carrier. Careful inspection should be made of the shipment as soon as it arrives and visible damage should be noted upon the carrier's receipt. Damage should be reported to the carrier. This damage is not covered under this warranty.
4. Warranty charges do not include freight or foreign, excise, municipal or other sales or use taxes. All such freight and taxes are the responsibility of the purchaser.
5. THIS WARRANTY IS EXCLUSIVE AND IS IN LIEU OF ALL OTHER WARRANTIES, EXPRESSED OR IMPLIED, INCLUDING ANY IMPLIED WARRANTY OR MERCHANTABILITY OR FITNESS FOR A PARTICULAR PURPOSE, EACH OF WHICH IS HEREBY EXPRESSLY DISCLAIMED. THE REMEDIES DESCRIBED ABOVE ARE EXCLUSIVE AND IN NO EVENT SHALL ANTUNES BE LIABLE FOR SPECIAL CONSEQUENTIAL OR INCIDENTAL DAMAGES FOR THE BREACH OR DELAY IN PERFORMANCE OF THIS WARRANTY.



<b>Corporate Headquarters</b>	<b>China Facility</b>
Carol Stream, Illinois	Suzhou, China
Phone: +1 (630) 784-1000	Phone: +86-512-6841-3637
Toll Free: +1 (800) 253-2991	Fax: +86-512-6841-3907
Fax: +1 (630) 784-1650	