



Variety Steamer

Model VS-350 owner's manual

Manufacturing Numbers:

9100703



VARIETY STEAMER

TABLE OF CONTENTS

Owner Information	2	Operation	10
General	2	Operator Controls	10
Warranty Information	2	Operating Instructions	11
Service/Technical Assistance	3	Programming	12
Important Safety Information	4	General Programming	12
Specifications	6	Factory Settings.....	12
Electrical Ratings.....	6	Programming the Unit	12
Dimensions.....	6	Maintenance	14
Shipping Weight	6	Daily Cleaning	14
Installation	7	Monthly: Cleaning the Steam Generator.....	14
Unpacking.....	7	Checking and Cleaning the Water Strainer.....	16
Equipment Setup	7	Technical Theory of Operation	18
Water Pressure Regulator Installation.....	7	Troubleshooting	19
Drain	8	Wiring Diagram	21
Electrical	8	Replacement Parts	22
Steaming Guide	9	Limited Warranty	24

OWNER INFORMATION

General

This manual provides the safety, installation and operating procedures for the Variety Steamer. We recommend that all information contained in this manual be read prior to installing and operating the unit.

Your Variety Steamer is manufactured from the finest materials available and is assembled to our strict quality standards. This unit has been tested at the factory to ensure dependable trouble-free operation.

Warranty Information

Please read the full text of the Limited Warranty in this manual.

If the unit arrives damaged, contact the carrier immediately and file a damage claim with them. Save all packing materials when filing a claim. Freight damage claims are the responsibility of the purchaser and **are not** covered under warranty.

The warranty does NOT extend to:

- Damages caused in shipment or damage as result of improper use.
- Installation of electrical service.
- Normal maintenance as outlined in this manual.
- Malfunction resulting from improper maintenance.
- Damage caused by abuse or careless handling.
- Damage from moisture into electrical components.
- Damage from tampering with, removal of, or changing any preset control or safety device.

IMPORTANT! Keep these instructions for future reference. If the unit changes ownership, be sure this manual accompanies the equipment.

OWNER INFORMATION (continued)

Service/Technical Assistance

If you experience any problems with the installation or operation of your unit, contact Antunes Technical Service at +1-877-392-7854 (toll free).

Use only genuine Antunes replacement parts in this unit. Use of replacement parts other than those supplied by the manufacturer will void the warranty.

Fill in the information below and have it handy when calling for assistance. The serial number is on the specification plate located on the rear of the unit.

Purchased From: _____

Date of Purchase: _____

Model No.: _____

Serial No.: _____

Mfg.. No.: _____

IMPORTANT

A.J. Antunes & Co. reserves the right to change specifications and product design without notice. Such revisions do NOT entitle the buyer to corresponding changes, improvements, additions or replacements for previously purchased equipment.

IMPORTANT SAFETY INFORMATION

In addition to the warnings and cautions in this manual, use the following guidelines for safe operation of the unit.

- Read all instructions before using equipment.
- For your safety, the equipment is furnished with a properly grounded cord connector. Do NOT attempt to defeat the grounded connector.
- Install or locate the equipment only for its intended use as described in this manual. Do NOT use corrosive chemicals in this equipment.
- Do NOT operate this equipment if it has a damaged cord or plug, if it is not working properly, or if it has been damaged or dropped.
- This equipment should be serviced by qualified personnel only. Contact Antunes Technical Service for adjustment or repair.
- Do NOT block or cover any openings on the unit.
- Do NOT immerse cord or plug in water.
- Keep cord away from heated surfaces.
- Do NOT allow cord to hang over edge of table or counter.
- This appliance is not to be used by persons (including children) with reduced physical, sensory, or mental capabilities, or lack of experience and knowledge unless they have been given supervision or instructions.
- Do not allow children to play with the appliance.

The following warnings and cautions appear throughout this manual and should be carefully observed.

- Turn the power off, unplug the power cord, and allow unit to cool down before performing any service or maintenance.
- The equipment should be grounded according to local electrical codes to prevent the possibility of electrical shock. It requires a grounded receptacle with separate electrical lines, protected by fuses or circuit breaker of the proper rating.

- All electrical connections must be in accordance with local electrical codes and any other applicable codes.
- **WARNING ELECTRICAL SHOCK HAZARD. FAILURE TO FOLLOW THESE INSTRUCTIONS COULD RESULT IN SERIOUS INJURY OR DEATH.**
 - Electrical ground is required on this unit.
 - Do NOT modify the power supply cord plug. If it does not fit the outlet, have a proper outlet installed by a qualified electrician.
 - Do NOT use an extension cord with this appliance.
 - Check with a qualified electrician if you are unsure if the appliance is properly grounded.
- If the supply cord is damaged, it must be replaced by the manufacturer or its service agent or a similarly qualified person.
- This equipment is to be installed to comply with the basic plumbing code of the Building Officials and Code Administrators, Inc. (BOCA) and the Food Service Sanitation Manual of the Food and Drug Administration (FDA).
- Water pressure must not exceed 30 psi (2.1 kg/cm² or 207 kPa). Higher water pressures may cause poor performance, flooding. To reduce water pressure, install a water pressure regulator and set water pressure to 20 -25 psi (1.4 - 1.7 kg/cm² or 138 - 172 kPa).
- Do NOT clean this appliance with a water jet.
- Do NOT use a sanitizing solution or abrasive materials. The use of these may cause damage to the stainless steel finish.

IMPORTANT SAFETY INFORMATION (continued)

- To ensure proper steaming characteristics, some calcium/mineral deposits must be present on the generator surface. If, during cleaning, the surface does become free of deposits, add plain tap water to the surface and allow it to boil off. This will ensure proper steaming characteristics by creating a thin layer of calcium/mineral deposits on the surface.
- Chlorides or phosphates in cleaning agents (e.g. bleach, sanitizers, degreasers, or detergents) could cause permanent damage to stainless steel equipment. The damage is usually in the form of discoloration, dulling of metal surface finish, pits, voids, holes or cracks. This damage is permanent and NOT covered by warranty:

The following tips are recommended for maintenance of your stainless steel equipment,

- Always use soft, damp cloth for cleaning, rinse with clear water and wipe dry. When required, always rub in direction of metal polish lines.
- Routine cleaning should be done daily using soap, ammonia detergent and water.
- Stains and spots should be removed with a vinegar solution as required.
- Finger marks and smears should be removed with soap and water.
- Hard water spots should be removed with a vinegar solution.

WARNING

**ELECTRICAL SHOCK HAZARD.
FAILURE TO FOLLOW THE INSTRUCTIONS IN
THIS MANUAL COULD RESULT IN SERIOUS INJURY OR DEATH.**

- Electrical ground is required on this appliance.
- Do NOT modify the power supply cord plug. If it does not fit the outlet, have a proper outlet installed by a qualified electrician.
- Do NOT use an extension cord with this unit.
- Check with a qualified electrician if you are unsure if the appliance is properly grounded.

CAUTION

All electrical connections must be in accordance with local electrical codes and any other applicable codes.

VARIETY STEAMER

SPECIFICATIONS

Electrical Ratings

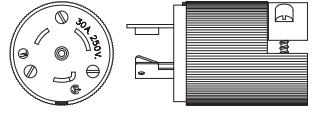
Model & Mfg. No.	Volt	Watts	Amp.	Hz.	Plug Description	Plug Configuration
VS-350 9700703	208	5000	24	50/60	L6-30P, 30 Amp., 250 VAC., Straight Twist Lock.	

Dimensions

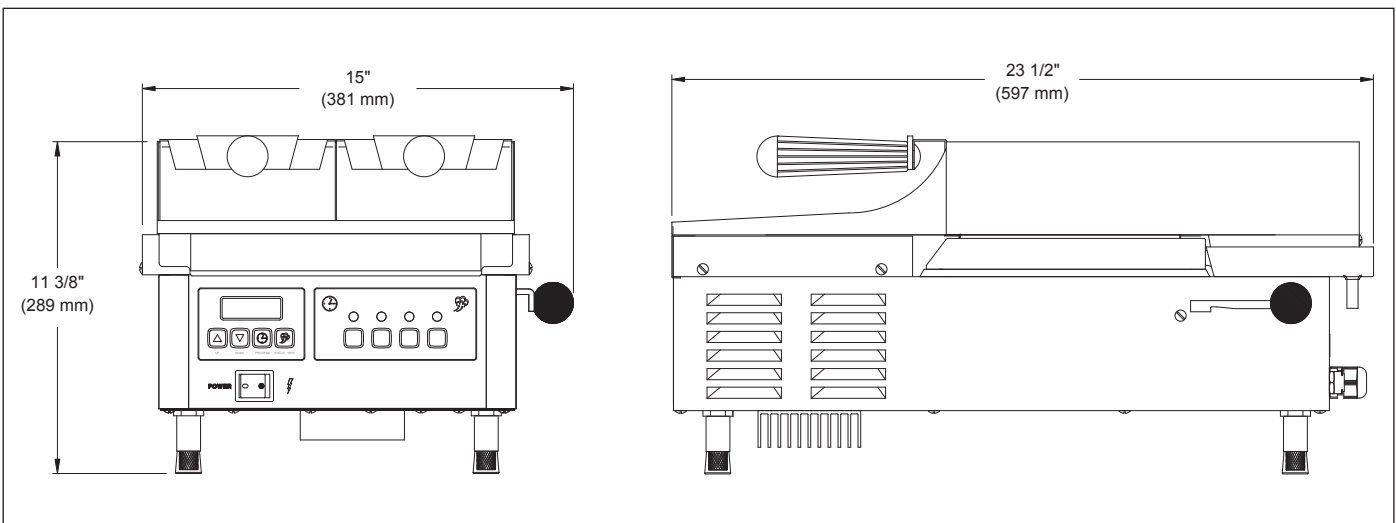

Shipping Weight

68 lbs. (31 kg)

INSTALLATION

Unpacking

1. Remove unit and all packing materials from shipping carton.
2. The unit should contain the following:
 - Owner's Manual
 - Petro Gel Tube
 - Inlet Hose and Strainer Assembly
 - Black Drain Tubing

NOTE: If any parts are missing or damaged, contact Antunes Customer Service IMMEDIATELY at +1-877-392-7856 (toll free).

3. Remove all packing materials and protective coverings from the unit.
4. Remove and wash all removable parts in soap and water. Rinse with clean hot water and allow to air dry.

NOTE: The steam generator surface will have a thin white coating of artificial lime deposits. This coating is necessary for steaming characteristics and should not be removed. Refer to the Maintenance section of this manual for more information.

5. Wipe all surfaces of the unit with a hot damp cloth.

NOTE: Do NOT use a dripping wet cloth. Wring out before use.

6. Re-install all removed parts.

Equipment Setup

GENERAL

When placing the unit into service, pay attention to the safety guidelines listed in the Important Safety Information section of this manual.

PLUMBING

NOTE: Variety Steamer models are designed to use cold tap water at 20-25 psi (1.4-1.7 kg/cm² or 138-172 kPa).

Your VS-350 requires direct water hookup. An Inlet Hose and Strainer assembly (Figure 2 and 2A) is supplied with the unit. A Water Pressure Regulator to feed 2 steamers (P/N 7000235 - Figure 2A) or to feed 1 steamer P/N 7000314 (Figure 2) must first be installed.

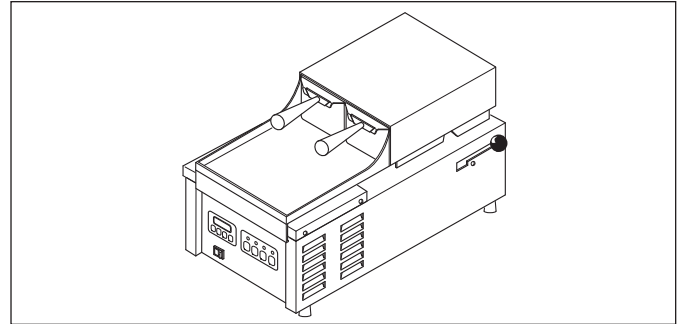

Figure 1. Variety Steamer

⚠ CAUTION ⚠

This equipment is to be installed to comply with the basic plumbing code of the Building Officials and Code Administrators, Inc. (BOCA) and the Food Service Sanitation Manual of the Food and Drug Administration (FDA).

Water Pressure Regulator Installation

1. Install the Water Pressure Regulator assembly to the steamer (Figures 2 and 2A).
2. Open the shut off valve to allow water flow to the Regulator. Ensure that the steamer pressure regulator is set at 20-25 psi. If not, confirm that incoming water pressure is above 25 psi and, if so, adjust the regulator by pulling softly on the knob and turning until the gauge reads desired pressure. Push in the knob to lock.

NOTE: If the pressure was adjusted, the existing pressure must be relieved in order to register the new set pressure

3. Push the white plastic tip on each 1/4" elbow Quick Disconnect (Figures 2 and 2A) and hold for a few seconds to purge out air in the line and allow water to flow freely into a bucket with a steady stream.
4. Push each 1/4" elbow Quick Disconnect into the rear of the steamer(s) until a "click" is heard. Turn on the steamers and allow 20 minutes to warm up. Cycle the unit three times and check the pressure regulator setting. If there is a change, adjust it again to read 20-25 psi and then push the knob in to lock. The unit is ready for use.

INSTALLATION (continued)

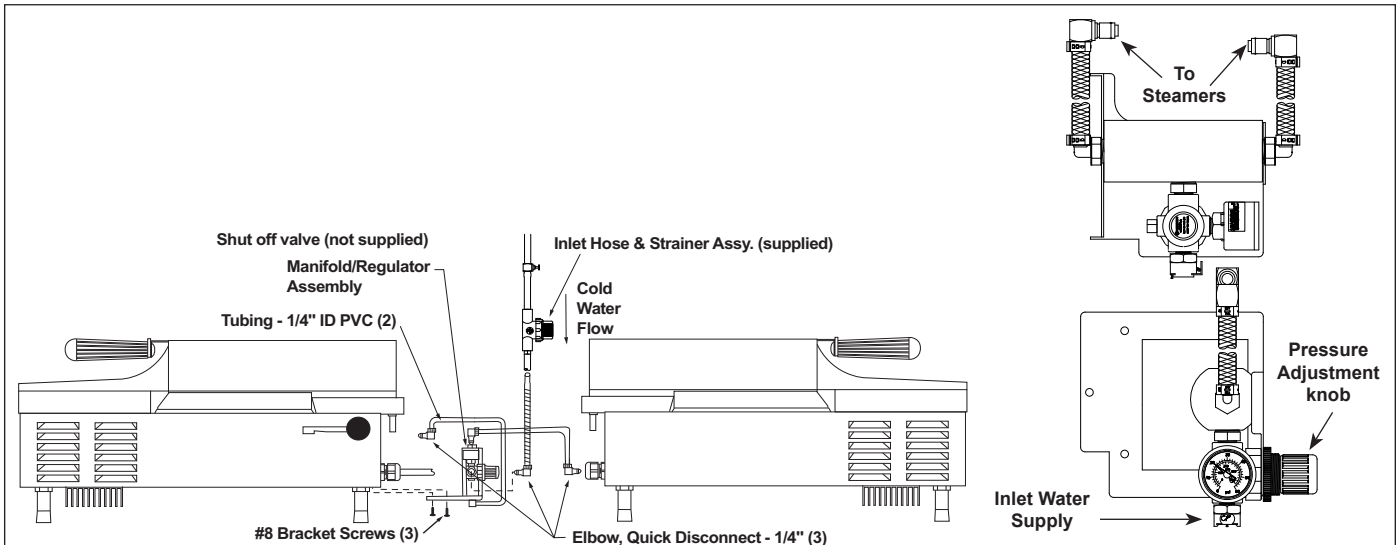

Figure 2A. Connecting Dual Manifold Water Pressure Regulator (P/N 7000235)

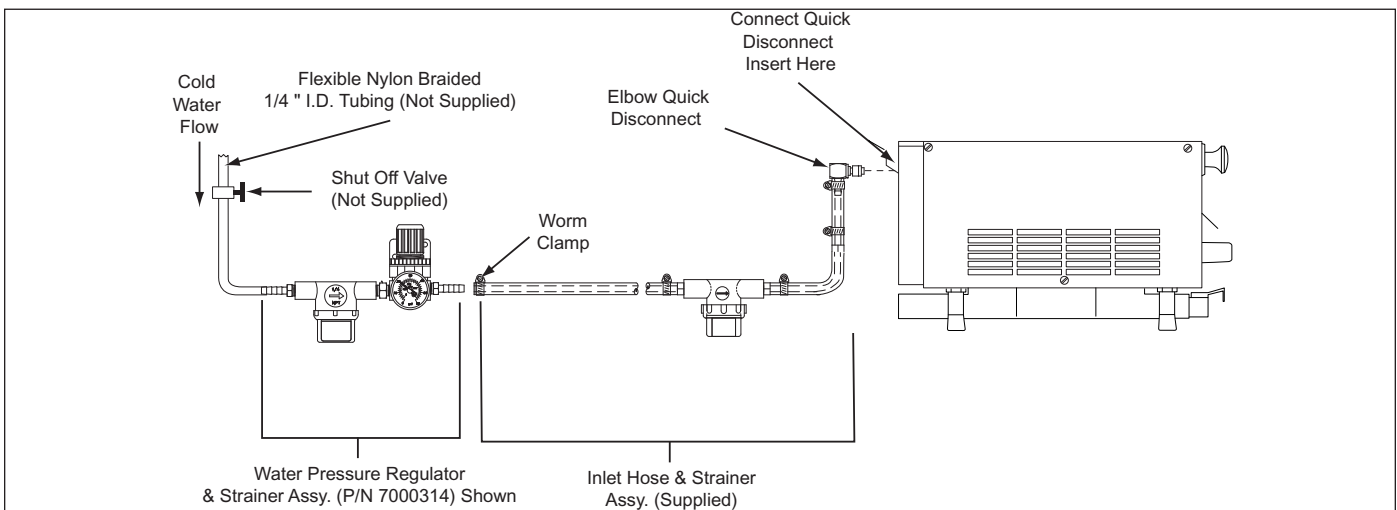

Figure 2. Connecting Single Water Pressure Regulator (P/N 7000314)

Drain

Connect the black drain tube to the drip tray by pressing the tube onto the drain pipe at the bottom of the drip tray. Place the other end of the tube in a drain or collection pan.

Electrical

1. Place the unit on a sturdy, level table or other work surface. Be sure the power is off proceeding.
2. Connect the unit to the power supply.

⚠ CAUTION ⚠

Water pressure must not exceed 30 psi (2.1 kg/cm² or 207 kPa). Higher water pressures may cause poor performance or flooding. To reduce water pressure, install a water pressure regulator, and set water pressure to 20-25 psi (1.4-1.7 kg/cm² or 138-172 kPa).

STEAMING GUIDE

The Variety Steamer makes it possible to expand a menu with just one piece of equipment. The Variety Steamer produces a super-heated dry steam. This steam penetrates the product until the product's temperature matches the steam temperature. The guide below is an approximation of the number of steam shots and the time required to cook the food item. Steam times may vary based on the state and quantity of the food product.

PRODUCT DESCRIPTION	TIME	PRODUCT DESCRIPTION	TIME
<i>Pre-Cooked Items</i>	<i>VS-350</i>	<i>Frozen Items</i>	<i>VS-350</i>
Spaghetti	25 seconds	Mixed Vegetables	55 seconds
Rice	25 seconds	Spaghetti	55 seconds
Egg Noodles	25 seconds	Ravioli	1 minute, 55 seconds
Macaroni	25 seconds	Tortellini	1 minute, 55 seconds
Ravioli	55 seconds	<i>Other</i>	
Tortellini	55 seconds	Poached Eggs	2 minutes, 45 seconds
Roast Beef, Sliced	15 seconds	Bread Products	5-15 seconds
Shrimp	35 seconds		
Tortilla Shell	5 seconds		
<i>Fresh Items</i>			
Shrimp	1 minute, 15 seconds		
Broccoli	1 minute, 35 seconds		

Products starting temperature is from a refrigerated state unless otherwise stated. This is also based on a full 20-ounce basket or two individual 10-ounce baskets.

VARIETY STEAMER

OPERATION

Operator Controls

POWER SWITCH

When the Power Switch is on, the Control Board is activated. If the generator temperature is below the factory preset setpoint, power is applied to the generator until the setpoint temperature is reached. The generator is constantly monitored and power is regulated to maintain the temperature setpoint.

MENU BUTTONS

When any menu button is pressed and released, power is supplied to the solenoid, the solenoid operates, and water sprays onto the heated steam generator surface. The water flashes immediately into live steam to heat the product.

One of two operational modes can be used: Single Shot or Timed Cycle

SINGLE SHOT

The **SINGLE SHOT** button (Figure 3) is pressed and released to initiate a single shot. The Control Board applies power to the solenoid and a single shot of steam occurs.

TIMED CYCLE

The desired timed steaming cycle (up to 99 minutes and 59 seconds) is selected by pressing and releasing any of the four menu buttons (Figure 3). The main Control Board applies power to the solenoid at regular intervals for the duration of the displayed cycle time. The display counts down to zero when the cycle is complete, then reverts back to the original programmed cycle time and the unit is ready for the next cycle.

IMPORTANT: Your steamer is factory programmed for the following (on each of the 4 menu channels):

- Total Cycle Time = 20 seconds [00:20]
(Range: 1 second to 99 minutes and 59 seconds)
- Shot Interval Rate (RATE) = 5 seconds [00:05]
(Range: 1 second to 5 minutes and 59 seconds)
- Steam Shot Time (SHOT) = 0.70 second [00:70]
(Range: 0.10 second to 2.50 seconds)

This converts approximately 3/4 oz. (25 milliliters) of water to steam every 5 seconds for a 10 second steaming cycle. To change any of these settings refer to the Programming section of this manual.

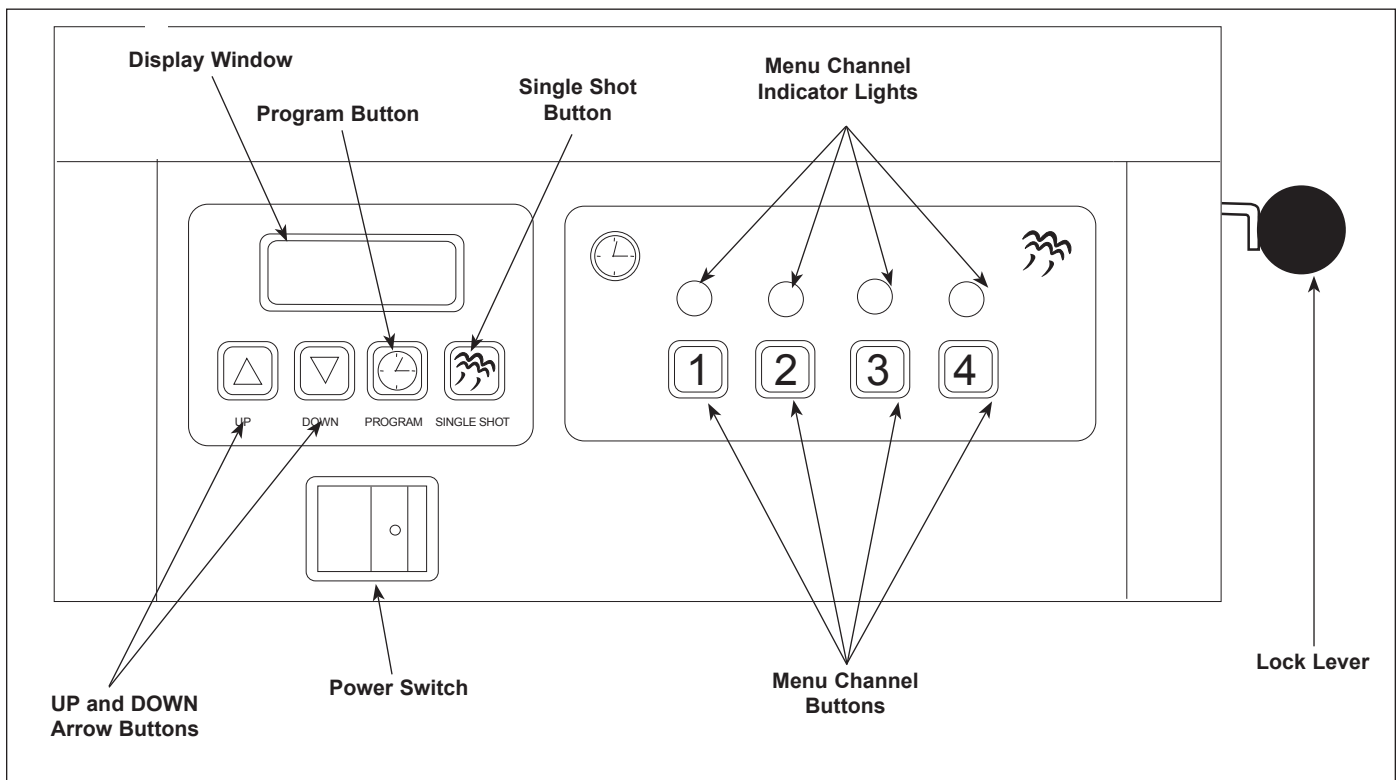

Figure 3. Operator Controls

PROGRAMMING (continued)

UP & DOWN ARROW BUTTONS

The actual generator temperature can be viewed by depressing the **UP ARROW** button (Figure 3) at any time. The arrow buttons are used with the other buttons to program the unit (see the Programming section of this manual for more information).

LOCK LEVER

When in the full forward (towards operator) position, the lock lever (Figure 8) secures the generator manifold in position on top of the unit. Moving the lock lever to the full rearward position unlocks the generator manifold, allowing it to be removed for cleaning or servicing.

NOTE: Do NOT force the lever into position.

HI-LIMIT RESET THERMOSTAT

If the generator overheats for any reason, the Hi-Limit Thermostat opens (trips) and cuts off power to the generator. This can be reset by turning the unit off, unplugging the power cord, and allowing the unit to cool for 45 minutes. Remove the Main Housing Cover and press the Hi-Limit Reset button (Figure 8). If the Hi-Limit Thermostat requires continuous resetting, contact Antunes Technical Service.

NOTE: Units manufactured on or before October 2002 have an externally resettable Hi-Limit. To reset it, remove the black protective cap located underneath the front of the unit and press the button fully. Reinstall the cap after resetting the unit.

Operating Instructions

1. Turn the unit on and allow it to preheat for approximately 30 minutes.

IMPORTANT: Do NOT push any of the menu buttons during warm-up. The word “LOW” flashes on the display to indicate the unit is not up to operating temperature. When the cycle time is displayed, the unit may be operated.

2. Remove baskets and place desired product into baskets. Insert baskets into the steamer.
3. **Single Shot:** Press and release the **SINGLE SHOT** button and wait 10 seconds for the steam to penetrate the product.

Timed Cycle: Momentarily pressing any one of the four channel buttons will begin a steaming cycle. During the cycle, the display will count down to zero ending with an audible tone to signal the completion of the cycle.

NOTE: Experiment by steaming product at different settings until correct cycle for that product is found.

4. When the cycle is complete, remove and empty the basket(s). At the end of the serving day or shift, turn off the unit and allow it to cool before performing the daily Cleaning procedures in the Maintenance section of this manual.

⚠ WARNING ⚠

To avoid injury, be careful when pulling basket assembly out from unit. Be sure to allow steam to escape before putting hands or face over the steamer.

Steaming Tips

Listed below are some samples of products that have been tested in the Variety Steamer. Recommended settings are listed following each product. Refer to the Programming section of this manual to setup the steamer for any of these items (results may vary).

Experiment with your products and different steaming times—a little more or less steam could change the appearance and/or flavor.

Pre-cooked pasta is easily reconstituted, and gives you a hot product without the wetness of the normal “dip” method. **CYC = 00.20, RATE = 00.05, SHOT = 00.55**

If you serve melted cheese on sandwiches, steam is the perfect way to melt cheese. **CYC = 00.10, RATE = 00.05, SHOT = 00.40**

A steamed bun (which takes about 10-15 seconds) says “Hot Sandwich” to your customer. **CYC = 00.10, RATE = 00.05, SHOT = 00.70**

Vegetables, rice, and bread products can be reconstituted by steaming before serving which reduces waste. **CYC = 00.20, RATE = 00.05, SHOT = 00.55**

Dinner rolls, muffins, even tortillas can be heated completely and held without drying out the product.

Use a low plate or pan when steaming to allow full steam penetration and shorter cooking times. Condensation inside the steamer is normal, but excess moisture indicates too much water is being used. See the Programming and Equipment Setup areas of this manual.

Heat meat and bread products apart from each other, then combine in a sandwich. This will keep the meat juices from soaking the bread. Finish off a special meal with a steamed hand towel—hot without excessive moisture.

VARIETY STEAMER

PROGRAMMING

Before starting initial programming, there are three items that should be verified.

- * Check/change the setpoint temperature of the generator. It is recommended that the generator be set at 375°F (191°C).
- * Change the display from Fahrenheit (F) to Celsius (C) or vice versa.
- * Verify the generator temperature after a 30-minute pre-heat time.

Listed below are the steps to follow for the recommendations listed above.

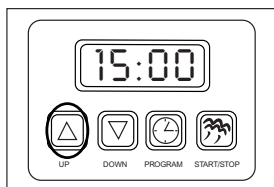

To verify the actual generator temperature, press and hold the **UP ARROW** button. The unit will display the actual generator temperature.

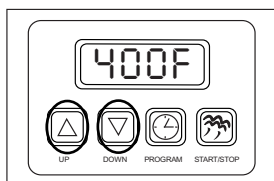

To verify or change the generator setpoint temperature, press and hold the **UP** and **DOWN ARROW** buttons simultaneously for three seconds. Then, raise or lower the temperature by depressing the **UP** or **DOWN ARROW** buttons. Release the buttons when the desired temperature is reached.

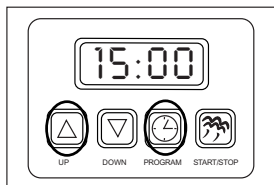

To Change the display from Fahrenheit (F) to Celsius (C), press and hold the **UP** arrow and the **PROGRAM** buttons simultaneously for three seconds. Repeat the process to reverse.

General Programming

CYC (Total Cycle Time) refers to the total amount of cooking time set for the product (Figure 4).

RATE (Shot Interval Time) is the time set between each shot of steam during a complete cycle (Figure 5).

SHOT (Steam Shot Time) is used to adjust the water volume used during each solenoid operation (shot of steam) (Figure 6).

The amount of steam produced by your unit depends on the amount of water sprayed onto the steam generator surface. Flooding of the generator may occur if the **SHOT** setting is too high or if the **RATE** setting is too low.

To prevent this from occurring, the **RATE** (Shot Interval Time) should be increased to allow more time for generator heat recovery, and the **SHOT** (Steam Shot Time) can be decreased to reduce the water volume.

Adjustments should be made to both values to determine the optimum settings for your cooking needs.

Factory Settings

The VS-350 is factory programmed for the following values for each of the 4 menu channels:

CYC = [00:10] 20 seconds
(Range: 1 second to 99 minutes 59 seconds)

RATE = [00:05] 5 seconds (**recommended**)
(Range: 1 second to 5 minutes 59 seconds)

SHOT = [00:70] 0.70 seconds (**recommended**)
(Range: 0.10 second to 2.50 seconds)

These settings deliver approximately 3/4 oz. (25 milliliters) of water every 5 seconds for a 10 second cooking time. Changes may be made to any of these settings. However, for optimum performance, settings should remain as shown above.

To restore the factory settings:

1. Turn the unit off. Press and hold the **PROGRAM** and **SINGLE SHOT** buttons.
2. Turn the unit on while still holding these buttons.
3. Release the buttons as soon as the unit stops beeping.

Programming the Unit

NOTE: CYC, RATE, and SHOT are sequential operations per channel for all programming (you must perform all steps for CYC and RATE to change SHOT).

NOTE: CYC, RATE, and SHOT are only displayed momentarily during the programming sequence when the PROGRAM button is pressed.

PROGRAMMING (continued)

CYC (Total Cycle Time)

1. Turn the power on (Figure 3). Allow 30 minutes to preheat the unit.

NOTE: During preheating, the display will flash "LOW". When unit reaches operating temperature, the display shows the factory pre programmed (default) time in minutes/seconds (Figure 7) and the active channel indicator light will be on.

2. Press the Program button to change the control from OPERATION to PROGRAM mode. CYC will appear in the display for a moment. Select a Menu Channel (1 thru 4), making the selected channel the active channel.

NOTE: If no change is made within 10 seconds at any time during the programming process, all changes made up to that point are stored in memory and the control reverts to OPERATION mode.

3. Press the **UP** or **DOWN ARROW** buttons to change the total cycle time in minutes (Figure 7).
4. Press the **PROGRAM** button again, then use the **UP** or **DOWN ARROW** buttons to change the total cycle time in seconds.
5. When finished, either:
 - a.) Press the selected menu channel button to store the changes; pressing this again will start the steam cycle.

OR

 - b.) Select another menu channel for change and repeat steps 3 & 4. Changes made to previous channels will automatically be stored.

RATE (Shot Interval Time)

6. While in Program mode (press the **PROGRAM** button if not in this mode), press both the **UP** and **DOWN ARROW** buttons simultaneously. RATE will appear in the display for a moment (Figure 5).
7. Use the **UP** or **DOWN ARROW** buttons to change the RATE setting in seconds.
8. Press the **PROGRAM** button again, then use the **UP** or **DOWN ARROW** buttons to change the rate time in minutes.

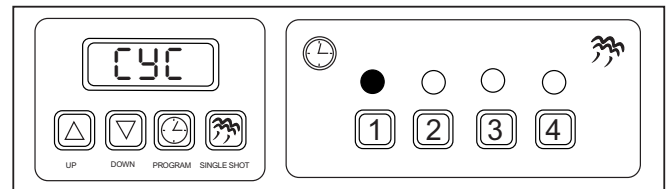

Figure 4. CYC Mode on Menu 1

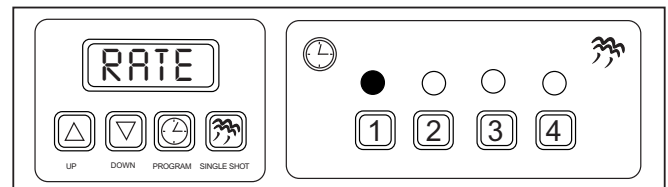

Figure 5. RATE Mode on Menu 1

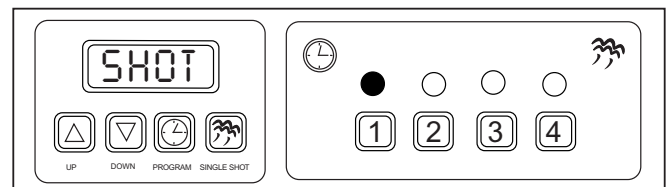

Figure 6. SHOT Mode on Menu 1

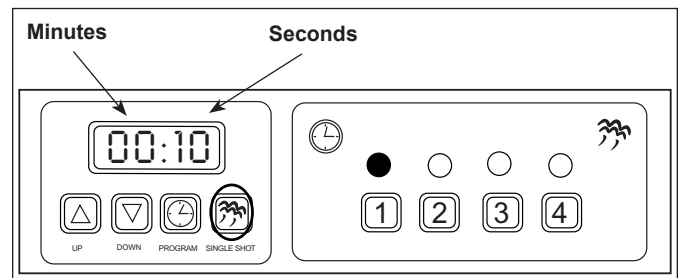

Figure 7. Programming Mode SINGLE SHOT Button Used for Saving All Changed Settings.

SHOT (Steam Shot Time)

9. Press the **PROGRAM** button again and SHOT will appear in the display for a moment (Figure 6).
10. Use the **UP** or **DOWN ARROW** buttons to increase or decrease the time.
11. Press the selected channel button to store the changes (Figure 6) or press another channel button to store the changes and select a new channel.
12. Repeat steps 1 - 11 for any of the other Menu Channels.

NOTE: The SINGLE SHOT button may be pressed at anytime during programming to store any changes made and execute a fixed single shot of 0.70 second.

VARIETY STEAMER

MAINTENANCE

⚠ WARNING ⚠

Turn the unit off, unplug the power cord, and allow the unit to cool down before performing any service or maintenance.

⚠ WARNING ⚠

Refer to the instructions for cleaning and handling the unit within the Important Safety Information section of this manual.

⚠ CAUTION ⚠

Do NOT use a sanitizing solution or abrasive materials. The use of these may cause damage to the stainless steel finish.

⚠ CAUTION ⚠

If a chemical cleaner is used, be sure it is safe to use on cast aluminum. Observe all precautions and warnings on product label.

⚠ CAUTION ⚠

Unplug power cord before moving and servicing this appliance.

⚠ CAUTION ⚠

Failure to regularly and/or properly clean this equipment may damage it or cause the user bodily injury.

Daily Cleaning

NOTE: Frequency of cleaning is determined by water conditions, usage and water filter systems.

1. Turn the unit off and unplug the power cord. Allow the unit to cool for approximately 30 minutes.
2. Check the rear water quick disconnect fitting and all hose clamp connections for leakage. If leakage is apparent, tighten all clamps or replace part(s) if required.
3. Remove baskets, top cover housing assembly, drip tray, and wash in hot, soapy water. Then, rinse these parts and allow them to air dry.
4. Remove the Black Manifold plate by slightly lifting and sliding the Locking lever (on the right side of the unit) towards the rear, carefully remove the plate and remove the large black O-ring from the plate.
5. Remove the diffuser plate and then remove the spray tube by carefully lifting the loose end and gently twisting and pulling it out of the steam generator hole.

6. Take a suitable 1/16" punching tool (such as a paperclip) and fully insert it through all 18 orifices in the black manifold as well as through the 10 orifices in the spray tube. This assures the orifices are not obstructed with debris.
7. Wash all items in hot, soapy water. Rinse these items and allow them to air dry.
8. Reinstall the spray tube into the steam generator hole and reinstall diffuser plate.
9. Lightly apply some Petrol Gel (included) onto the large black O-ring and reinstall the O-ring onto the manifold plate (this allows the manifold plate to seat easily onto the steam generator). Hold the manifold plate up to a light source and verify that light is visible through all the orifices. If so, seat the manifold fully onto the generator and pull the locking lever forward to lock the plate.
10. Check that the water pressure regulator is correctly set to 20 PSI (1.4 kg/cm² or 138 kPa).
11. Reinstall all parts and accessories.

Monthly: Cleaning the Steam Generator

Your steamer utilizes an open steam generator. Water sprayed onto the generator surface flashes into steam immediately, but the minerals in the water do not steam, they stay on the generator surface. **A small amount of calcium/mineral deposits are needed for proper operation**, but a build-up of excessive calcium/mineral deposits causes poor steaming efficiency, excessive moisture (wet steam) and will eventually affect the steaming action completely.

1. Turn the power off, unplug the power cord and allow the unit to cool down before proceeding.
2. Perform the Daily Cleaning procedures, but do NOT reassemble the unit.
3. With the unit cool, use a non-abrasive brass brush and/or scraper to loosen and remove the excessive calcium/mineral deposits from the generator surface (Figure 8). Wipe the generator with a clean damp cloth. Reassemble the unit.

NOTE: If deposits are still excessive and/or difficult to remove, see Step 4.

4. Wearing protective eye wear and gloves, pour delimer solution (not supplied) onto the generator surface (Figure 8). Be sure to follow the delimer manufacturer's directions for proper mixture and use.

MAINTENANCE (continued)

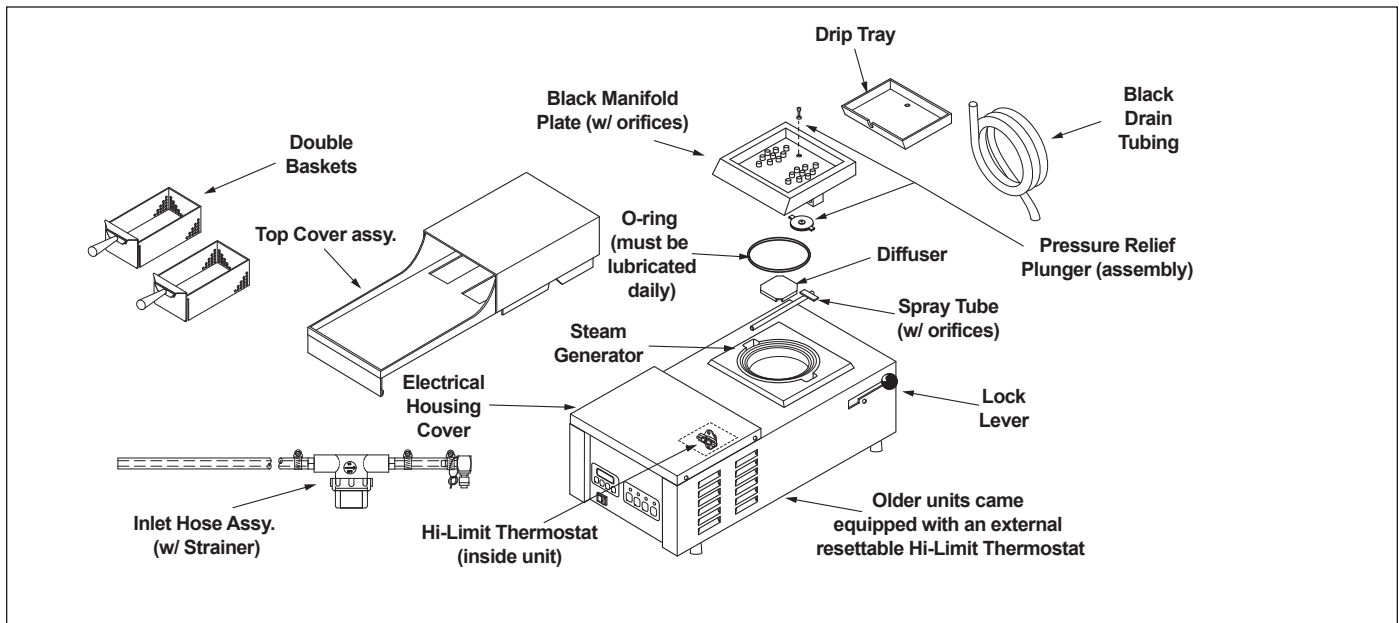

Figure 8. Variety Steamer Components & Accessories

⚠ CAUTION ⚠

If a chemical cleaner/delimer is used, be sure it is safe to use on cast aluminum. Observe all precautions and warnings on the product label.

- Using a sponge or dry towel, remove the delimer solution from the generator. Then, rinse the generator with clear water.

NOTE: To ensure proper steaming characteristics, some calcium/mineral deposits must be present on the generator surface. If, during cleaning, the surface does become free of calcium/mineral deposits, add plain tap water to the surface and allow it to boil off. This may have to be repeated several times in order to formulate a thin coating of deposits. If unsuccessful, see below.

NOTE: In soft water areas, it may be necessary to add a small amount of lime to the generator surface to “season” it. This will ensure proper steaming characteristics by producing a thin coating of calcium/mineral deposits on the generator surface. Seasoning mixture consists of 3/4 ounces (25ml/25cc) of baking soda, 3/4 ounces (25ml/25cc) of lime and 1 quart (950ml/950cc) of water. Stir mixture and pour 1/4” deep into hot generator. After mixture is converted to steam, the remaining loose powder can be wiped off.

- Plug power cord into electrical outlet
- Turn power on and allow the unit 30 minutes to warm up.
- Use the **SINGLE SHOT** button to cycle unit three separate times to purge remaining delimer from generator.

PRESSURE RELIEF PLUNGER

The Pressure Relief Plunger (Figure 8) protects the equipment and user from any harm that can result if the orifices of the Black Manifold Plate (Figure 8) has not been cleaned according to the Daily Cleaning Procedures in this manual. When the orifices become restricted or clogged, steam pressure builds up within the black manifold plate. This pressure build-up eventually forces the Pressure Relief Plunger to elevate and relieve the pressure, generating a loud “whistling” sound. If at any time this condition should occur, the unit must be cleaned according to the Daily Cleaning Procedures in this manual. Maintenance procedures are not covered by warranty.

NOTE: Be sure that the Plunger Relief Valve is securely mounted to the Plunger Weldment.

VARIETY STEAMER

MAINTENANCE (continued)

Checking and Cleaning the Water Strainer

GENERAL

The Water Strainer protects the unit from any foreign debris in the water line that could get into the food, damage the unit's solenoid (causing the unit to leak or flood), or interfere with the equipment's proper and consistent operation (Figure 10).

To ensure proper and consistent steaming results, visually check the water pressure regulator gauge and strainer cup regularly. If the pressure on the gauge has dropped, visually check the clear plastic strainer "cup" and clean out the accumulated debris as follows.

1. Shut off the water supply valve to the unit, unscrew the clear plastic strainer "cup" and carefully remove the mesh strainer screen.

2. Take the strainer cup and mesh strainer to the sink and gently flush all the accumulated debris out of them, be especially careful not to damage the mesh strainer screen.
3. Carefully place the mesh strainer screen into its seat at the bottom of the clear plastic cup and confirm that the orange O-ring is properly seated in its place before screwing the Strainer cup and top back together.
4. Purge the air out of the strainer and tubing by disconnecting the male quick disconnect fitting from the equipment and, over a bucket, pushing its "white" plastic tip in until there is a good water flow.
5. Replace damaged or worn parts as needed.

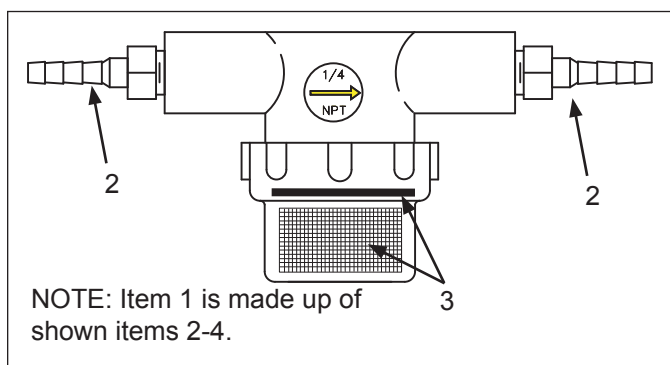

Figure 10. Water Line Strainer Kit

Item	Part No.	Description	Qty.
1	7000333	Water Line Strainer Kit	1
2	2040130	Male Adapter, barbed - 1/4"	2
3	7000334	Replacement Screen and O-ring Kit	1
4	2110104	Clamp, Worm (Not shown)	2

Diagnostics

The four-channel controller is also equipped with diagnostic features. Listed under each drawing is a brief description of the particular feature. Also contained in the control housing mounted on the control board are diagnostic LED's. They are in three colors and represent the following:

- * **Green (Program):** When lit, indicates factory settings are being set.
- * **Yellow (Audio):** When lit, indicates 10-15 VDC is being supplied to the audio signal. The Audio Signal will sound for 3 seconds.
- * **Red (Heat):** When lit, indicates the unit is calling for heat by supplying 3-5 VDC to the solid state relay. When off, it indicates the heating circuit is satisfied.

- * **Green (Water):** When lit, indicates that 24 VAC is being supplied to open the solenoid.

NOTE: This LED is only lit for approximately one second.

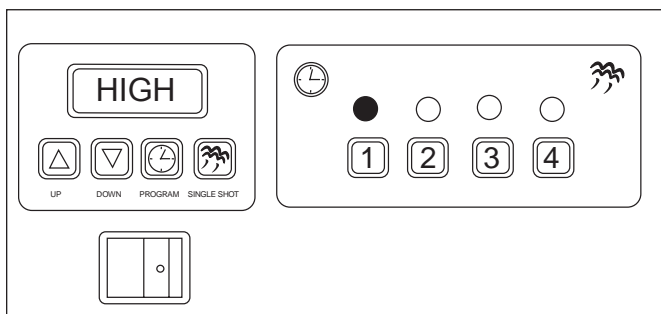

HIGH will be displayed when the generator temperature exceeds the setpoint temperature by 50°F (10°C).

MAINTENANCE (continued)

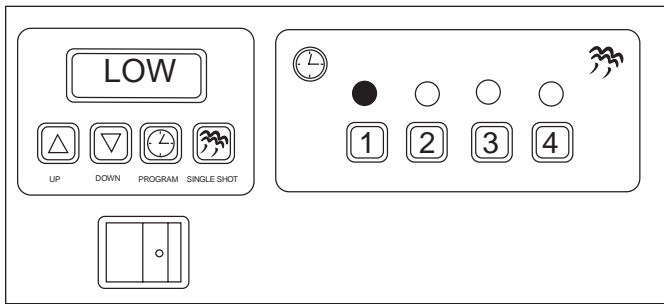

LOW will be displayed until the generator temperature exceeds 250°F (121°C).

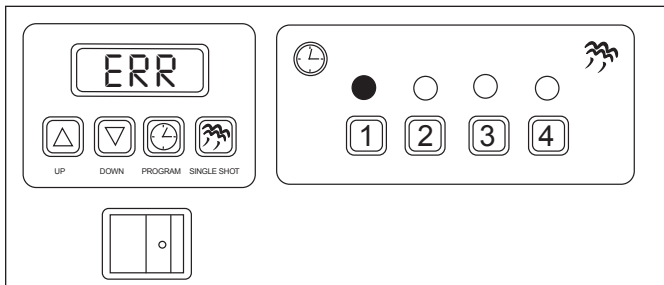

ERR will be displayed if there is a programming parameters error. If this message appears you will have to clear the current parameters. To clear the unit's current programming and reset the unit to its factory settings:

1. Turn the unit off.
2. Push the **SINGLE SHOT** and **PROGRAM** buttons simultaneously and, while turning the unit back on, continue to hold them until you hear the beep stop.
3. Check the display:
 - If the Display shows "ERR" again, repeat steps 1 through 2. If "ERR" still appears on the display, contact your maintenance person or Antunes Technical Service.
 - If the Display appears normal, try a single shot before attempting to reprogram the unit.

Review the Programming section of this manual and then program the Menu Channel Buttons according to your cooking requirements.

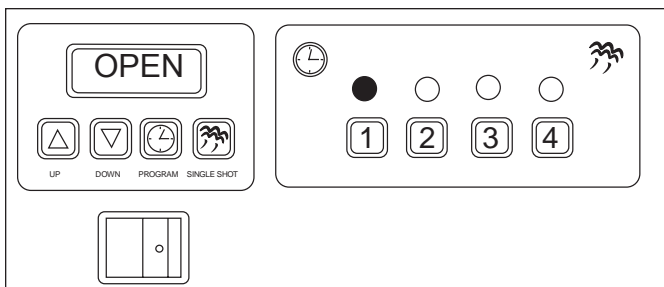

OPEN will be displayed when the thermocouple is "open" or not installed correctly. The unit will not call for heat.

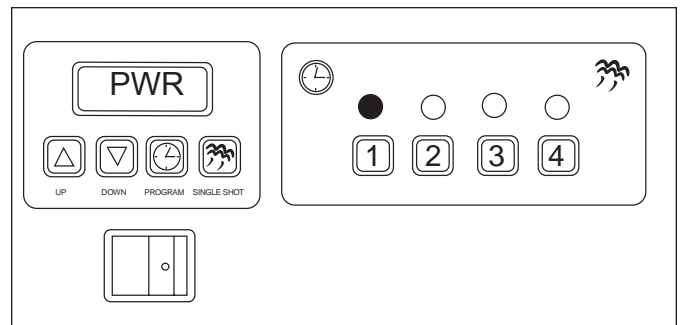

PWR will be displayed when the supply voltage is lower than 160 Volts AC or above 265 Volts AC.

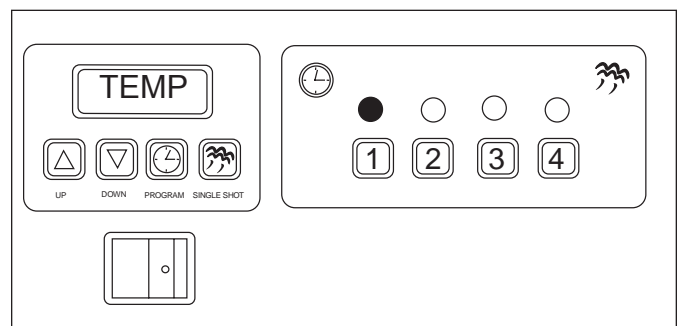

TEMP indicates the control cabinet temperature has exceeded 155°F (68°C) causing the unit to shut down.

The TEMP Display indicates that the control cabinet temperature has exceeded 155°F (68°C). If this occurs, the unit must be turned off for at least 20 minutes so that it can cool off and reset. If this condition occurs again, contact your maintenance person or service Agency.

The Control Board monitors the control cabinet ambient temperature and records the highest temperature. Your service technician could find such information very useful when troubleshooting the unit.

To determine the control cabinet's highest temperature since the last reset:

1. Turn the unit off and then back on while pressing both the **UP** and **DOWN ARROW** buttons at the same time.
2. Read the highest control cabinet temperature recorded on the display and release the arrow buttons.
3. Turn the unit off again to preserve this record.

To clear/reset this record, press both the **UP** and **DOWN ARROW** buttons simultaneously (before turning the unit off) and the display will show 33°F—indicating that record has been cleared—and then turn the unit off.

MAINTENANCE (continued)

Technical Theory of Operation

When the Rocker Switch (power On/Off) is ON, line voltage flows to the primary side of the step down transformer. The transformer's secondary side supplies 12 and 24 VAC to the Control Board.

Once powered, and provided that the generator's temperature is below the setpoint temperature, the Control Board calls for heat by supplying 3 to 5 VDC to the Solid State Relay terminals 3 (+) 4 (-). Once powered, the Solid State Relay then closes terminals 1 and 2, which allows line voltage to flow to the generator.

As the generator begins to heat up, a type "K" thermocouple monitors the internal generator temperature. As the heat continues to increase, so does the thermocouple's DC millivolts.

Once the generator's temperature approaches the setpoint temperature, the Control Board begins to pulse the VDC to the Solid State Relay. The generator's VAC and AMPS will also pulse during this point. When the generator's temperature is between the recommended set points of 375 - 400° F (190 - 204° C), the thermocouple generates approximately 7.5 - 8.5 DC millivolts. The Control Board receives these millivolts and proceeds to remove the 3-5 VDC to the Solid State Relay since the heating circuit has now become satisfied.

Then, the Solid State Relay terminals 1 and 2 open up, and the generator stops heating. The heating circuit cycles on and off as needed, even at idle.

When the Single Shot button is pushed, it signals the Control Board to initiate a single shot of steam. The Control Board then supplies 24 VAC to the Solenoid Valve for a split second. The Solenoid Valve opens and allows approximately 3/4 - 1 ounce (4 to 5 tablespoons) of water to be disbursed onto the generator surface for steaming. The water is immediately converted into steam, which is forced up through the black Manifold Orifices to steam the product within the baskets.

Each of the four channel buttons can be custom programmed for cycle time, time between when each steam shot occurs, and water volume used per each shot (See the Programming section of this manual). An audio signal will sound for three seconds at the end of the cycle.

Two safety devices are incorporated into the VS-350:

- Hi-Limit Thermostat
- Pressure Relief Plunger

If the heating circuit continues to call for heat and the generator overheats, a manual resettable Hi-Limit Thermostat will trip and open the generator circuit.

If water and or steam pressure builds up beneath the black Manifold Plate (due to restricted Manifold Plate orifices), a Pressure Relief Plunger will elevate and vent the steam pressure above the manifold plate.

NOTE: If any of these conditions should arise, the root cause must be determined and corrected. See the Maintenance section of this manual for further details.

NOTE: All direct water fed units require a Water Pressure Regulator. It should be set to 20-25 psi (1.4-1.7 kg/cm² or 138-172 kPa). Failure to install a Water Pressure Regulator will result in poor steaming and flooding of the steam generator.

TROUBLESHOOTING

⚠ WARNING ⚠

To avoid possible personal injury and/or damage to the unit, inspection, test and repair of electrical equipment should be performed by qualified service personnel. The unit should be unplugged when servicing, except when electrical tests are required.

Problem	Possible Cause	Corrective Action
Power Switch is turned on but the Switch Indicator Light is still off and the Control Panel is blank.	Power cord not correctly plugged in.	Plug in the power cord correctly.
	The power cord and/or electrical plug is damaged.	Inspect electrical wire, plug, and receptacle.
	The main electrical panel circuit breaker is off or has been tripped.	Reset circuit breaker. Contact your maintenance person or Antunes Technical Service if it trips again.
	Power Switch is inoperable.	Contact your maintenance person Antunes Technical Service for service.
The unit's main electrical panel circuit breaker trips.	Damaged receptacle, plug, or cord; a loose connection or an internal component failure.	Turn the power off, allow it to cool to room temperature, and then restart the unit.
Power Switch and Indicator Light are on but the display is blank.	Control Board is inoperable.	Contact your maintenance person or Antunes Technical Service for service.
	Transformer is inoperable.	
	Loose or burnt wiring in heating circuit.	
Power Switch is turned on, the Switch Indicator Light is on, the Control Panel Display is on, but the unit is not heating up.	Heat Relay is inoperable.	Reset the Hi-Limit Thermostat according to the Operations section of this manual. If the Hi-Limit Thermostat requires continuous resetting, contact your maintenance person or Antunes Technical Service for service.
	Hi-Limit Thermostat is tripped.	
	Thermocouple is inoperable.	
	Control Board is inoperable.	
	Steam Generator is inoperable.	
	Loose or burnt wiring in heating circuit.	
Unit heats but there is little or no steam produced and/or The product requires more steaming than usual.	Water Line Valve is closed.	Check that the Water Line Valve is open.
	Filter Strainer is restricted.	Check and clean the Filter Strainer as described in the Maintenance section of this manual.
	Quick Disconnect is not fully engaged at rear of the unit or is damaged.	Remove and reengage the Quick Disconnect firmly until a "click" is heard. Replace if damaged.
	Low or no water pressure in water line.	Remove the Quick Disconnect Insert from the rear of the unit. While holding into an empty cup, press the white plastic tip. Strong steady water flow should be noted. If so, re-engage firmly into unit. If not present, or pressure is low, contact your maintenance person or plumber.
	Spray Tube is restricted.	Remove and clean Spray Tube as described in the Maintenance section of this manual.
	Black Manifold orifices are restricted.	Remove and clean the Black Manifold as described in the Maintenance section of this manual.
	Unit is not being cleaned daily or properly.	Clean unit daily as described in the Maintenance section of this manual.

VARIETY STEAMER

TROUBLESHOOTING (continued)

Problem	Possible Cause	Corrective Action
Unit heats but there is little or no steam produced and/or The product requires more steaming than usual (continued).	Improper water pressure to unit.	Verify that a water pressure regulator is installed and set to 20-25 psi.
	Insufficient or excessive calcium/mineral buildup on Generator surface.	Verify that a thin layer of deposits is present on the Generator surface. Refer to the Maintenance section of this manual.
	Channels, or Rate and Shot values were programmed improperly.	Restore programming to original values as described in the Programming section of this manual and then reprogram as needed.
	Black Manifold O-ring is damaged or missing.	Install Manifold O-ring if missing. Replace if it is damaged.
	Low Generator setpoint temperature.	Verify the set point temperature is 375°F (190°C) to 400°F (204°C).
Steam leaks out of the sides of the Black Manifold Plate.	Black Manifold O-ring is damaged or missing.	Install Manifold O-ring if missing. Replace if it is damaged.
Black Manifold is difficult to lock and unlock onto the generator with the sliding lever.	Black Manifold not being removed and cleaned daily as required.	Remove and clean the Black Manifold daily as described in the Maintenance section of this manual.
	Black Manifold O-Ring is damaged or worn.	Replace Black Manifold O-Ring if damaged or worn.
	Black Manifold O-ring is not being lubricated daily with Petro gel.	Lubricate the Black Manifold O-ring daily as described in the Maintenance section of this manual.
	Generator is dirty.	Clean or de-lime the Generator. See the Maintenance section of this manual for more information.
Unit floods overnight and/or continues to steam even when in idle mode.	Solenoid valve is being held open by debris from the building's water line piping due to no pre-strainer/filter on the water line just before the unit.	Attempt to flush the debris out of the valve by rapidly operating the unit on a number of "Single Shot" cycles and then letting the unit rest. If the unit still leaks, contact your maintenance person or Antunes Technical Service.
Unit is whistling during use.	Unit is not being cleaned daily and/or properly.	See the Maintenance section of this manual.

WIRING DIAGRAM

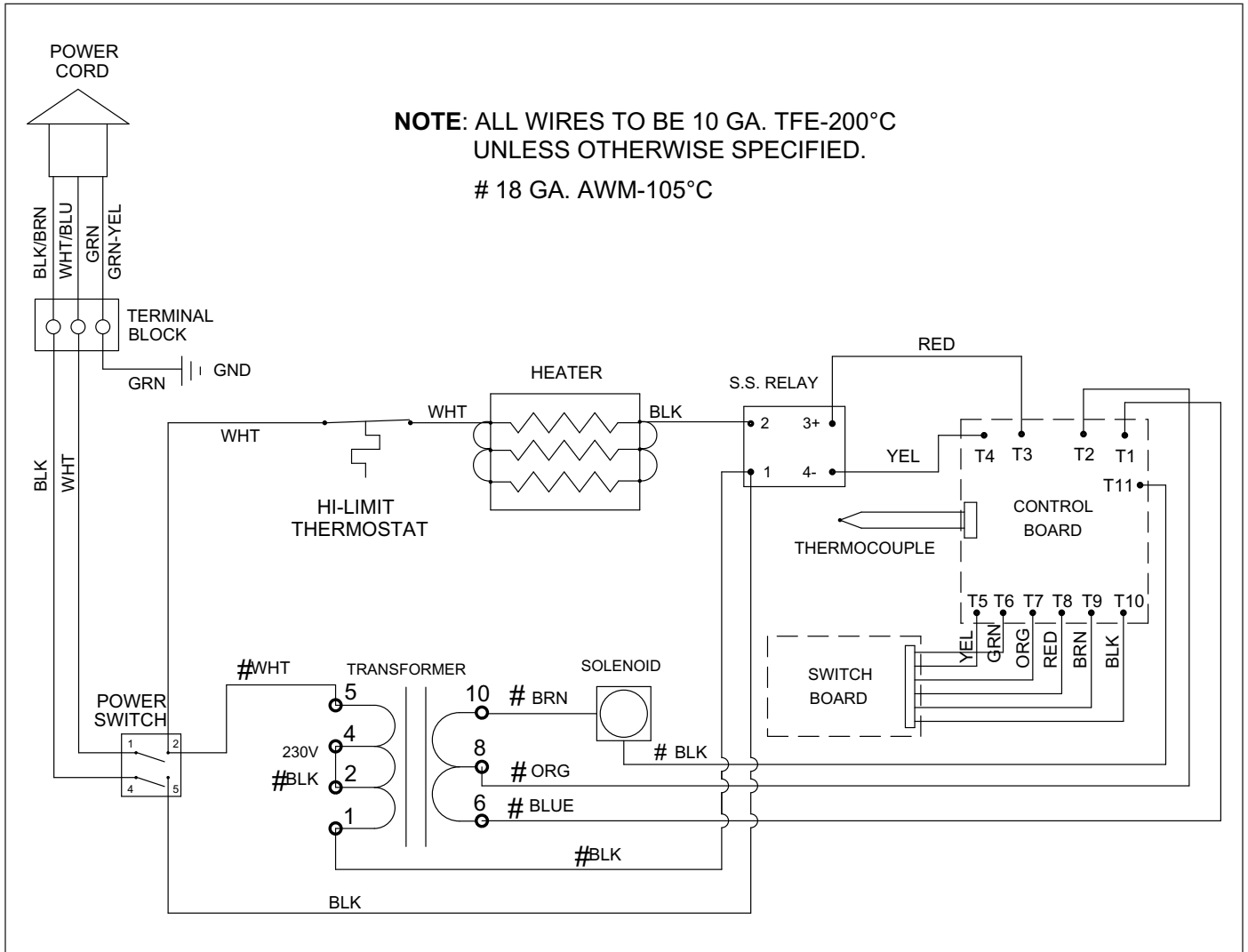

VARIETY STEAMER

REPLACEMENT PARTS

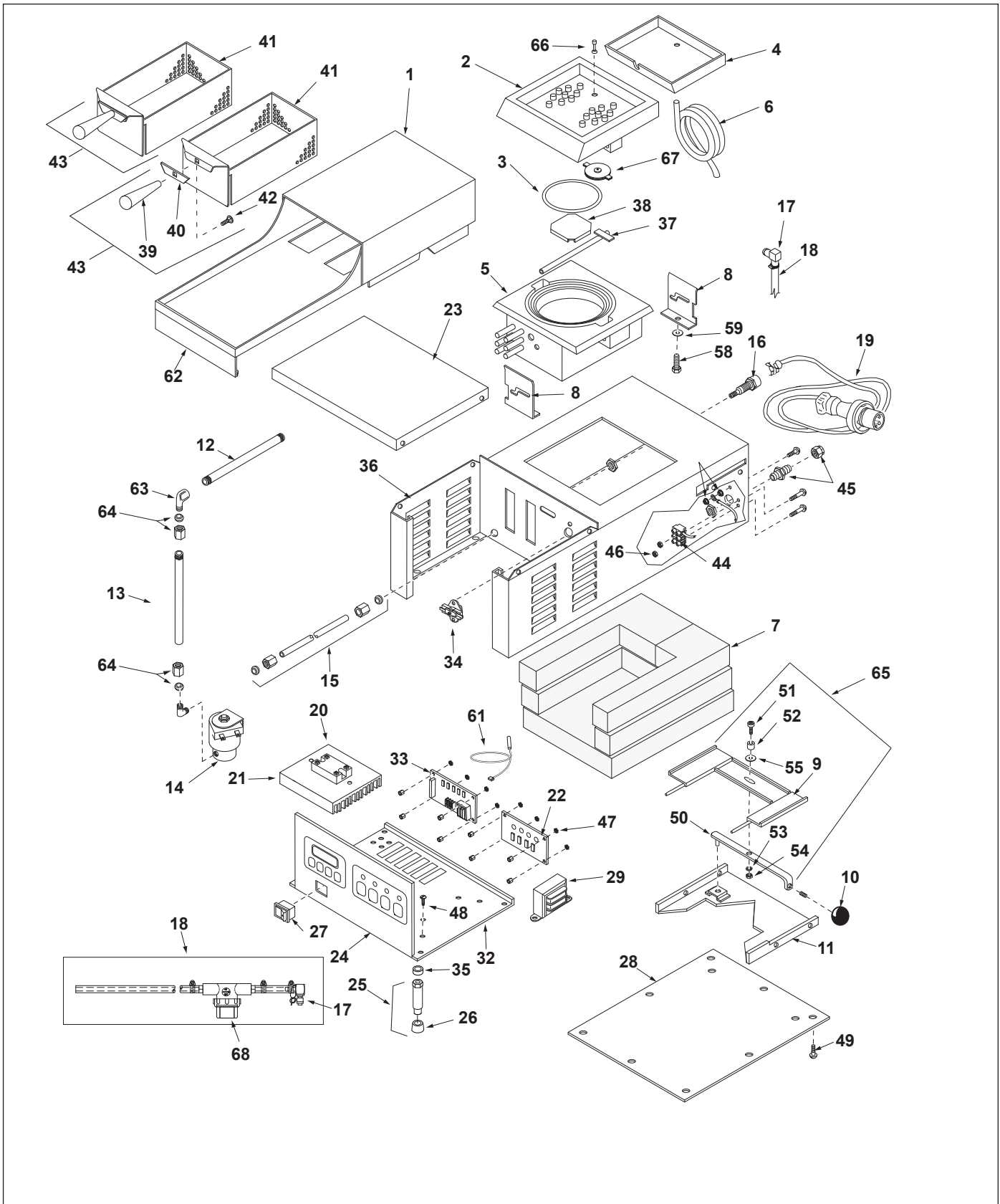

REPLACEMENT PARTS (continued)

Item	Part No.	Description	Qty.
1	0011539	Top Housing Assy. (Jumbo)	1
2	7000404	Generator Manifold (incl. #66 & 67)	1
3	0200187	O-Ring	1
4	0020947	Drip Tray Assy.	1
5	7000293	Generator, (208V) 5000w	1
6	2020104	Drain Tube	1
7	7000297	Insulation	1
8	0501139	Retainer, Generator	2
9	0021040	Channel, Lock Lever Support	1
10	2100138	Ball Knob	1
11	0021038	Lever Support	1
12	2190102	Tube	1
13	2000214	Tube SS 1/4"	1
14	4040145	Solenoid	1
15	7000890	VS-350 Inlet Tube Kit	1
16	208K106	Quick Disconnect Body	1
17	7000139	Quick Disconnect Insert	1
18	0010584	Inlet Hose Assy. (incl. #17 & 68)	1
19	0700479	Power Cord, L6-30P	1
20	7000403	Solid State Relay Kit (Incl. #21)	1
21	4050232	Heat Sink	1
22	4010192	Board, Switch PC	1
23	0503776	Cover, Main Housing	1
24	1001058	Label, Control Panel	1
25	0011370	2" Leg	4
		(Incl. No. 26)	1
26	2100109	Rubber Foot, Leg	4
27	4010137	Rocker Switch, Power On/Off	1
28	0020946	Panel, Bottom	1
29	7000319	Transformer, 115/230V-24V	1
30	0700591	Wire Set (not shown)	1
31	2140116	Petrol Gel (not shown)	1
32	0021244	Control Panel	1
33	4070229	Control Board	1
34	7000344	Hi-limit Thermostat Kit ** (See NOTE below)	1
35	2120171	Front Leg Spacer	2
36	0021041	Main Housing	1
37	0020958	Spray Tube	1

Item	Part No.	Description	Qty.
38	0502669	Diffuser	1
39	2100119	Handle	2
40	2100201	Handle Guard, Black	2
41	0022258	Basket	2
42	338P102	Bolt, Square Neck, 3/8-16 x 3/4" SS	2
43	0013506	Basket Assy (Incl. 39, 40, 41 & 42)	2
44	406K006	Terminal Block, 3-Pole	1
45	0400315	Strain Relief	1
46	308P143*	Nut, Hex, KEPS, #8-32	1
47	304P105*	Nut, Hex, KEPS, #4-20, Zinc	1
48	310P120*	Screw, Machine, #10-32 x 5/8"	1
49	308P103*	Screw, Machine, #8-32 x 1/4"	1
50	0021039	Lock Lever Weldment	
51	325P169	Bolt, Shoulder, 5/16 x 1/2"	1
52	212P120	Spacer, .437" O.D. x .340 I.D.	1
53	325P154	Washer, Helical Spring Lock, 1/4"	1
54	325P102	Nut, Hex, 1/4-20	1
55	212P118	Washer, Flat, SS	1
58	325P109*	Bolt, Hex Hd., 1/4-20 x 1/2"	1
59	325P104*	Washer, Flat, 1/4"	1
61	4050214	Type "K" Thermocouple	1
62	1001053	Cleaning Label	1
63	204P114*	Female Elbow 1/4" Tube	1
64	2040126	Nut & Sleeve Assy. 1/4"	2
65	0011071	Lock Lever Assy. (Incl. 9, 50, 51, 52, 53, 54, & 55)	1
66	2170115	Plunger Valve	1
67	0021474	Plunger Weldment	1
68		See page 16 for Strainer Parts identification.	1

* Only available in packages of 10.

**** NOTE: VS-350 units manufactured with serial numbers 0210XXXX and prior were manufactured with an external manual resettable capillary bulb Hi-Limit Thermostat. If this type of Hi-Limit Thermostat should require replacement, it must be replaced with a bi-metal type (P/N 7000344) and retrofitted into unit.**

LIMITED WARRANTY

Equipment manufactured by A.J. Antunes & Co. (Antunes) has been constructed of the finest materials available and manufactured to high quality standards. These units are warranted to be free from electrical and mechanical defects for a period of one (1) year from date of purchase under normal use and service, and when installed in accordance with manufacturer's recommendations. To insure continued operation of the units, follow the maintenance procedures outlined in the Owner's Manual. During the first 12 months, electromechanical parts, non-overtime labor, and travel expenses up to 2 hours (100 miles/160 km), round trip from the nearest Authorized Service Center are covered.

1. This warranty does not cover cost of installation, defects caused by improper storage or handling prior to placing of the Equipment. This warranty does not cover overtime charges or work done by unauthorized service agencies or personnel. This warranty does not cover normal maintenance, calibration, or regular adjustments as specified in operating and maintenance instructions of this manual, and/or labor involved in moving adjacent objects to gain access to the equipment. This warranty does not cover consumable/wear items. This warranty does not cover damage to the Load Cell or Load Cell Assembly due to abuse, misuse, dropping of unit/shock loads or exceeding maximum weight capacity (4 lbs). This warranty does not cover water contamination problems such as foreign material in water lines or inside solenoid valves. It does not cover water pressure problems or failures resulting from improper/incorrect voltage supply. This warranty does not cover Travel Time & Mileage in excess of 2 hours (100 miles/160 km) round trip from the nearest authorized service agency.
2. Antunes reserves the right to make changes in design or add any improvements on any product. The right is always reserved to modify equipment because of factors beyond our control and government regulations. Changes to update equipment do not constitute a warranty charge.
3. If shipment is damaged in transit, the purchaser should make a claim directly upon the carrier. Careful inspection should be made of the shipment as soon as it arrives and visible damage should be noted upon the carrier's receipt. Damage should be reported to the carrier. This damage is not covered under this warranty.
4. Warranty charges do not include freight or foreign, excise, municipal or other sales or use taxes. All such freight and taxes are the responsibility of the purchaser.
5. THIS WARRANTY IS EXCLUSIVE AND IS IN LIEU OF ALL OTHER WARRANTIES, EXPRESSED OR IMPLIED, INCLUDING ANY IMPLIED WARRANTY OR MERCHANTABILITY OR FITNESS FOR A PARTICULAR PURPOSE, EACH OF WHICH IS HEREBY EXPRESSLY DISCLAIMED. THE REMEDIES DESCRIBED ABOVE ARE EXCLUSIVE AND IN NO EVENT SHALL ANTUNES BE LIABLE FOR SPECIAL CONSEQUENTIAL OR INCIDENTAL DAMAGES FOR THE BREACH OR DELAY IN PERFORMANCE OF THIS WARRANTY.



Corporate Headquarters

Carol Stream, Illinois

Phone: +1 (630) 784-1000

Toll Free: +1 (800) 253-2991

Fax: +1 (630) 784-1650

China Facility

Suzhou, China

Phone: +86-512-6841-3637

Fax: +86-512-6841-3907