

The robust, stainless steel Polar80 vacuum packaging machine is standard equipped with a Busch vacuum pump. This floor model is perfect for those looking to vacuum seal large quantities.

STANDARD FEATURES

- Standard with 2 seal bars: 760mm (front), 510mm (right)
- Liquid Control
- Other seal bar configurations available for free (front-back, left-right)
- Standard double seal (two wires).
- Silicone holders easily removable for cleaning and maintenance purposes
- Pump capacity: 100m³/h Busch vacuum pump
- Pump maintenance and cleaning program
- Machine cycle: 15-40 sec
- Standard Digital control with 10 program memory and Time control
- Flat work plate
- Comes with insert plates for a faster cycle and product adjustment
- Stainless steel exterior
- IP-65 Rating
- Service kit for standard maintenance

OPTIONAL

- Sensor control, Advanced Control System (ACS)
- Gas flush (incl. pressed air connection)
- Preparation for external pump

ACCESSORIES

- Zebra ZD410 thermal label printer (only in combination with ACS)
- Inclined insert plate (for vacuum packing liquids and powders)

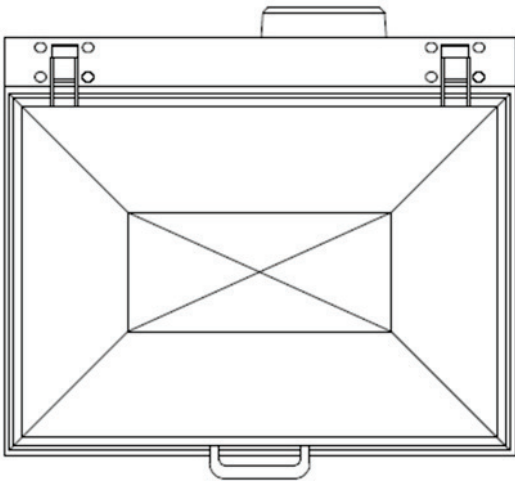

DIMENSIONS

External dimensions: 900W x 790D x 1100H mm

Chamber (usable space): 510W x 760D x 200H mm

TECHNICAL DATA

Voltage (Hz): 3NAC 400V 50Hz

Pump Capacity (m³/h): 100

Power (kW): 2.3

Weight: 248kg

RCM Approved:

SPECIFICATIONS ARE SUBJECT TO CHANGE WITHOUT NOTICE.

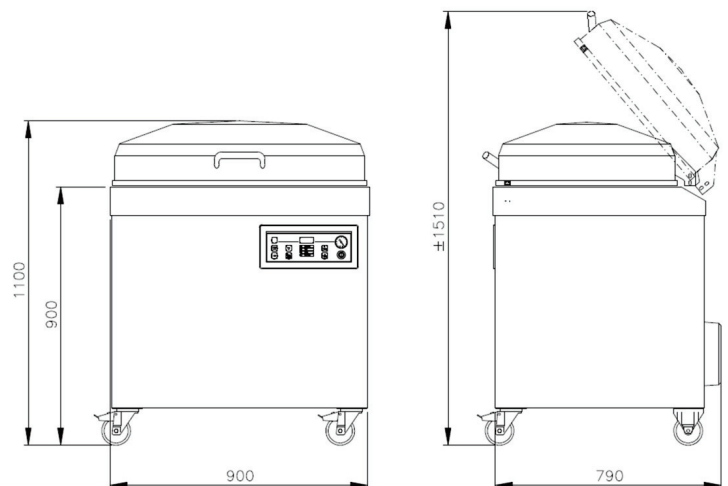

Busch vacuum pumps, world leaders in vacuum pump technology.



Two years parts & labour warranty