

Operating Instructions

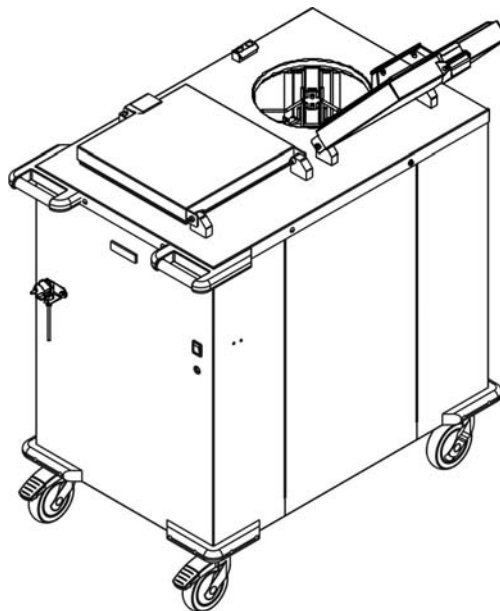

Distributed by
Comcater Pty Ltd
156 Swann Drive
Derrimut VIC 3030
Phone: (03) 8369 4600
Fax: (03) 8369 4696
www.comcater.com.au



Powerstapler PSUH

1 Introduction

1.1 Appliance Information

Appliance name	Powerstapler
Appliance type/s	PSUH
Year of manufacture	2015
Manufacturer	HUPFER® Metallwerke GmbH & Co. KG Dieselstraße 20 48653 Coesfeld Germany Postfach 1463 48634 Coesfeld Germany ☎ +49 2541 80 50 📠 +49 2541 805 111 www.hupfer.de info@hupfer.de

Read these operating instructions carefully before using the appliance for the first time.

Ensure that operating staff have been briefed regarding sources of danger and possible incorrect handling.

Subject to modifications

The products covered by these operating instructions have been developed while taking into account market requirements and the latest technology. HUPFER® reserves the right to modify the products and related technical documentation in the interests of technical progress. The data and weights as well as the description of performance and functions assured in the order confirmation as binding are always decisive.

Manual edition
91346811_A1

1.2 Table of Contents

1	Introduction	2
1.1	Appliance Information	2
1.2	Table of Contents	3
1.3	List of Abbreviations	5
1.4	Definitions of Terms	6
1.5	Orientation of the Appliance	7
1.6	Notes on Using the Manual	8
1.6.1	Notes on the Manual Structure	8
1.6.2	Notes and their Representation used in all Sections	8
2	Safety Instructions	9
2.1	Introduction	9
2.2	Warning Symbols Used	9
2.3	Safety Instructions for Appliance Safety	9
2.4	Safety Instructions for Cleaning and Care	11
2.5	Safety Instructions Regarding Fault Repair	11
2.6	Notes on Specific Hazards	11
3	Description and Technical Data	12
3.1	Performance Description	12
3.2	Proper Use	12
3.3	Improper Use	12
3.4	Appliance Description	13
3.4.1	View of the Appliance	13
3.4.2	Appliance Description	13
3.5	Technical Data	14
3.6	Rating Plate	15
4	Transport, Installation, Initial Operation and Taking out of Service	16
4.1	Transport	16
4.2	Commissioning	16
4.3	Storage and Recycling	16
5	Operation	17
5.1	Arrangement and Function of the Controls	17
5.2	Adjustment of the Powerstapler	18
5.2.1	Springs Adjustment	18
5.2.2	Calculating the capacity for Powerstapler	20
5.3	Operation	21
5.4	Measures at the End of Use	23



6	Troubleshooting and Repair	24
6.1	Safety Measures	24
6.2	Instructions regarding Fault Repair	24
6.3	Fault and Action Table	24
7	Cleaning and care	26
7.1	Safety Measures	26
7.2	Hygiene Measures	26
7.3	Cleaning and care	26
7.4	Special Care Instructions	27
8	Spare Parts and Accessories	28
8.1	Introduction	28
8.2	Spare Parts and Accessories List	28
9	Annex	29
9.1	EC Declaration of Conformity	29

1.3 List of Abbreviations

Abbreviation	Definition																																				
DGUV	German Statutory Accident Insurance (<i>Deutsche Gesetzliche Unfallversicherung e.V.</i>)																																				
DIN	German Institute for Standardisation, technical regulations and technical specifications																																				
EN	European Standard (<i>Europäische Norm</i>) Harmonised standard for the EU market																																				
E/V	Spare or wearing part (<i>Ersatz- bzw. Verschleißteil</i>)																																				
HACCP	Hazard Analysis and Critical Control Points Hazard analysis of critical control points																																				
IEC	International Electrotechnical Commission																																				
IP	International Protection. The abbreviation IP and a further two-digit index specify the protection class of a housing. The first digit: Protection against ingress of solid foreign objects The second digit: Protection against ingress of water <table border="1" data-bbox="577 772 1412 1527"> <tbody> <tr> <td>0</td> <td>No protection against contact, no protection against ingress of solid foreign bodies</td> <td>0</td> <td>No protection against ingress of water</td> </tr> <tr> <td>1</td> <td>Protection against contact with any large surface of the body such as the hand, protection against ingress of foreign objects $\varnothing > 1.97''$ (50 mm)</td> <td>1</td> <td>Protection against dripping water (vertically falling drops)</td> </tr> <tr> <td>2</td> <td>Protection against contact with the fingers, protection against ingress of foreign objects $\varnothing > 0.5''$ (12 mm)</td> <td>2</td> <td>Protection against dripping water (at any angle up to 15° from the vertical)</td> </tr> <tr> <td>3</td> <td>Protection against contact with tools, wires or similar objects of $\varnothing > 0.1''$ (2.5 mm), protection against foreign objects $\varnothing > 0.1''$ (2.5 mm)</td> <td>3</td> <td>Protection against water drips at any angle up to 60° from the vertical</td> </tr> <tr> <td>4</td> <td>Protection against contact with tools, wires or similar objects of $\varnothing > 0.04''$ (1 mm), protection against foreign objects $\varnothing 0.04''$ (>1 mm)</td> <td>4</td> <td>Protection against water splashing from any direction</td> </tr> <tr> <td>5</td> <td>Protection against contact, protection against dust deposits inside</td> <td>5</td> <td>Protection against water jets (projected by a nozzle) at any angle</td> </tr> <tr> <td>6</td> <td>Complete protection against contact, protection against ingress of dust</td> <td>6</td> <td>Protection against rough sea or strong water jets (flood protection)</td> </tr> <tr> <td></td> <td></td> <td>7</td> <td>Protection against ingress of water during temporary immersion</td> </tr> <tr> <td></td> <td></td> <td>8</td> <td>Protection against pressurised water during continuous immersion</td> </tr> </tbody> </table>	0	No protection against contact, no protection against ingress of solid foreign bodies	0	No protection against ingress of water	1	Protection against contact with any large surface of the body such as the hand, protection against ingress of foreign objects $\varnothing > 1.97''$ (50 mm)	1	Protection against dripping water (vertically falling drops)	2	Protection against contact with the fingers, protection against ingress of foreign objects $\varnothing > 0.5''$ (12 mm)	2	Protection against dripping water (at any angle up to 15° from the vertical)	3	Protection against contact with tools, wires or similar objects of $\varnothing > 0.1''$ (2.5 mm), protection against foreign objects $\varnothing > 0.1''$ (2.5 mm)	3	Protection against water drips at any angle up to 60° from the vertical	4	Protection against contact with tools, wires or similar objects of $\varnothing > 0.04''$ (1 mm), protection against foreign objects $\varnothing 0.04''$ (>1 mm)	4	Protection against water splashing from any direction	5	Protection against contact, protection against dust deposits inside	5	Protection against water jets (projected by a nozzle) at any angle	6	Complete protection against contact, protection against ingress of dust	6	Protection against rough sea or strong water jets (flood protection)			7	Protection against ingress of water during temporary immersion			8	Protection against pressurised water during continuous immersion
0	No protection against contact, no protection against ingress of solid foreign bodies	0	No protection against ingress of water																																		
1	Protection against contact with any large surface of the body such as the hand, protection against ingress of foreign objects $\varnothing > 1.97''$ (50 mm)	1	Protection against dripping water (vertically falling drops)																																		
2	Protection against contact with the fingers, protection against ingress of foreign objects $\varnothing > 0.5''$ (12 mm)	2	Protection against dripping water (at any angle up to 15° from the vertical)																																		
3	Protection against contact with tools, wires or similar objects of $\varnothing > 0.1''$ (2.5 mm), protection against foreign objects $\varnothing > 0.1''$ (2.5 mm)	3	Protection against water drips at any angle up to 60° from the vertical																																		
4	Protection against contact with tools, wires or similar objects of $\varnothing > 0.04''$ (1 mm), protection against foreign objects $\varnothing 0.04''$ (>1 mm)	4	Protection against water splashing from any direction																																		
5	Protection against contact, protection against dust deposits inside	5	Protection against water jets (projected by a nozzle) at any angle																																		
6	Complete protection against contact, protection against ingress of dust	6	Protection against rough sea or strong water jets (flood protection)																																		
		7	Protection against ingress of water during temporary immersion																																		
		8	Protection against pressurised water during continuous immersion																																		
LED	Light Emitting Diode Light diode																																				
LMHV	Regulation on the hygiene of foodstuffs																																				
RCD	Residual Current Device Residual current device (RCD)																																				
STB	Safety temperature limiter																																				
VDE	Association of Electrical Engineering, Electronics and Information Technology (<i>Verband der Elektrotechnik, Elektronik und Informationstechnik e.V.</i>)																																				

1.4 Definitions of Terms

Term	Definition
Authorised specialist	An authorised specialist is a specialist that has been trained by the manufacturer, an authorised service dealer or a company assigned by the manufacturer.
Check, inspect	Compare with certain conditions and/or characteristics such as damage, leaks, filling levels and heat.
Cleaning system-resistant	<p>The suitability of the appliance for cleaning in an automated cleaning system is limited. It is possible to achieve a flawless, reproducible cleaning and drying result, but it cannot be guaranteed.</p> <p>The exterior and interior housing are produced to standard specifications. Water ingressing hollow spaces resulting from the design of the appliance can run off without hindrance. Water collection in hollow spaces is avoided. Installed electrical components and electrical wiring are protected by appropriate sealing (for example, labyrinth edges, sealing profiles, cable channels) against any form of penetration by water. Protection class IPX6 (powerful pressurised water) to DIN EN 60529 (VDE 0470) is guaranteed. It is possible that water remains and is carried over following the drying process.</p>
Convection	Physical properties or mass transfer (e.g. heat or cold) through currents in gases and liquids.
Cook&Chill Kitchens	"Cook and Chill": Kitchens where warm food is chilled as quickly as possible after being cooked.
Cook&Serve Kitchens	"Cook and Serve": Kitchens where warm food is served immediately after being cooked or kept warm until it is consumed.
Corrosion	The chemical reaction of a metallic material with its surroundings, e.g. rust.
Cover	A bell-shaped cover for keeping food warm on plates and dishes.
Element formation	Also: contact corrosion. Occurs when different noble metals are in close contact with each other. This happens when a corrosive medium is between both metals, such as water or even normal air moisture.
EM field	Electrical, magnetic or electromagnetic field that is defined by its field intensity and phase formation.
EN tray	A European standard tray is a tray in a standard size. EN 1/1 corresponds to 20.9x14.6" (530x370 mm), EN 1/2 corresponds to 14.6x10.4" (370x265 mm).
Gastronorm	Gastronorm is a measurement system used worldwide in places such as food processing plants or large-scale kitchens. The use of standardised sizes makes it possible to exchange food pans. The basic size of the Gastronorm (GN) 1/1 is 20.9 x 12.8" (530x325 mm). Items are available in different depths.
GN tray	A Gastronorm standard tray is a standard-size tray. GN 1/1 corresponds to 20.9x12.8" (530x325 mm), GN 1/2 corresponds to 12.8x10.4" (325x265 mm).
H1	Hygienic standard (NSF/USDA) for lubricants that are suitable for incidental and technically unavoidable contact with foodstuffs.
HACCP	The HACCP concept is a preventive system that should ensure the safety of foods and consumers.
Instructed person	An instructed person is a person who has been instructed on the possible risks resulting from improper behaviour when carrying out an assigned task and regarding the necessary protective equipment and protective measures, and who has been trained for this task, if necessary.
Lift	A movement, for example a vertical movement of the guide basket from bottom to top.
Machine safety	The term machine safety refers to all the measures used to avert injury to persons. The basis for machine safety is directives and laws for protecting users of technical devices and systems valid nationally and across the EC.
Passive layer	A non-metallic protective layer on a metallic material that prevents or slows down material corrosion.

Term	Definition
Porcelain Standard	Porcelain Standard is a measurement system for porcelain plates devised by HUPFER®. The basic size of Porcelain Standard (PN) 1/1 is 8.7 x 6.3" (220x160 mm) (1/2 PN conforms to 4.3x6.3" (110x160 mm), 1/4 PN conforms to 6.3x3.1" (160x80 mm)). The fitting lids have the following dimensions: 1/1 PN 9x6.6" (228x168mm), 1/2 PN 4.4x6.3" (111x161mm), 1/4 PN 4.4x3.2" (111x81mm).
Protection class	<p>0 -</p> <p>I  Protective measure with protective earth conductor</p> <p>II  Protective measure with protective insulation</p> <p>III  Protective measure with protective low voltage</p>
Qualified person, qualified personnel	Qualified personnel are persons who due to their professional training, experience, instruction and their knowledge of relevant standards, guidelines, accident prevention regulations and operating conditions have been authorised by a person responsible for system safety to carry out required activities and can recognise and prevent any potential hazards (definition of specialists according to IEC 364).
Regulation on the hygiene of foodstuffs	Regulations regarding hygiene requirements for producing, handling and placing food on the market
Schuko®	The abbreviation of the German term "Protective contact" indicates a system of domestic plugs and sockets equipped with protective earthed contacts used in most of Europe.
Specialist	A specialist is a person who can assess work assigned and can recognise possible hazards themselves based on their professional training, skills, experience and knowledge of the respective guidelines.
Suitable for washing devices	The appliance is suitable for cleaning in an automated cleaning system without restrictions. Following agreement with the manufacturer the cleaning system must achieve a hygienic, constant cleaning and drying result, which is to be approved by a third party (client). The exterior and interior housing are manufactured to a standard guaranteeing hermetic sealing. It is not possible for water jets to ingress into hollow spaces in the appliance. Installed electrical components and electrical wiring are protected by appropriate sealing against any form of penetration by water. Protection class IPX6 (powerful pressurised water) to DIN EN 60529 (VDE 0470) is guaranteed. No water remains or is carried over following the drying process.
Verify, test	Compare with certain values such as weight, torque, content or temperature.
VESKA standard	Trays as per the VESKA standard are items used for distributing food in hospitals, principally in Switzerland; they measure 20.87 x 14.76" (530x375 mm).

1.5 Orientation of the Appliance

The front

The "front" refers to the side of the Powerstapler where the push handles are arranged. The operating staff stays at this side to move the appliance. The controls are also located at the front side.

The rear

The "rear" refers to the opposite side to the front.

The right

The "right" refers to the right hand side when viewed from the front side (front).

The left



The "left" refers to the left hand side when viewed from the front side (front).

1.6 Notes on Using the Manual

1.6.1 Notes on the Manual Structure

This manual is divided into function- and task-focused sections.

1.6.2 Notes and their Representation used in all Sections

DANGER	Brief description of hazard
	<p>There is an imminent threat to life and physical well-being for the user and / or third parties if instructions are not followed precisely or the circumstances described are not taken into account.</p> <p>The type of hazard is indicated by a symbol and explained in the accompanying text in more detail. The general symbol for danger is used in this example.</p>
WARNING	Brief description of hazard
	<p>There is an indirect threat to life and physical well-being for the user and / or third parties if the instructions are not followed precisely or the circumstances described are not taken into account.</p> <p>The type of hazard is indicated by a symbol and explained in the accompanying text in more detail. The general symbol for danger is used in this example.</p>
CAUTION	Brief description of hazard
	<p>There is a potential risk of injury or property damage if the instructions are not followed precisely or the circumstances described are not taken into account.</p> <p>The type of hazard is indicated by a general symbol and explained in the accompanying text in more detail. The general symbol for danger is used in this example.</p>
NOTE	Brief description of additional information
	<p>Attention is pointed to special conditions or additional important information on the topic concerned.</p>
INFO	Short title
	<p>It contains additional information on work ease or recommendations on the topic concerned.</p>

2 Safety Instructions







2.1 Introduction

The section on safety instructions describes the risks associated with the appliance in terms of product liability (according to the EU Directive).

2.2 Warning Symbols Used

Symbols are used in these operating instructions to indicate the dangers that may occur while operating or cleaning the appliance. In both cases, the symbol provides information on the type and circumstances of hazards.

The following symbols may be used:

	General hazard area
	Hazardous electrical voltage
	Risk of hand injuries
	Hazard caused by hot surfaces
	Wear hand protection
	Read and observe the operating instructions

2.3 Safety Instructions for Appliance Safety

The appliance is operated safely if it is used correctly and carefully. Negligent handling of the appliance can lead to a threat to life and physical well-being for the user and / or third parties as well as hazards for the appliance itself and the operator's other property.

The following points are to be observed to ensure the appliance safety:

- The appliance may only be operated when it is in perfect condition with regards to technical standards.
- All operating and actuating elements must be in a perfect and fail-safe condition with regards to technical standards.
- Modifications or retrofits to the equipment are only permitted after consultation with the manufacturer and upon receipt of their consent in writing.
- People must not sit or stand on the appliance under any circumstances. Transport of persons is not permitted.
- Before loading, the crockery dispensing height must be adjusted to the items to be used.
- Never push the stacking platform down manually into the stacking compartment (e.g. for cleaning). There is a risk of injury when released.
- The appliance is designed for transport by hand only. It is not permitted to use a machine of any type to move the appliance. Risk of injury and damage.
- Do not forcibly press down excessively high stacks with the covers. There is a risk of injury if the locking is released. Furthermore, the locking function of the covers can be damaged.

- Release both total locks before moving the appliance. Moving the appliance when the total locks are engaged can damage the chassis.
- The appliance may only be transported over level floors. Moving the appliance over very uneven floors can damage the chassis.
- It is not permitted to transport the appliance over steep inclines or steps.
- When approaching walls and moving round obstacles, always be aware for persons in your path. Risk of injury.
- To transport the appliance, always hold both push handles with your hands. Never let go of the appliance while moving it.
- Move no faster than at walking pace when transporting the appliance. Heavily laden Powerstapler are difficult to brake and steer. If necessary, ask for assistance when transporting the appliance.
- Never try to catch the Powerstapler with your hands if it tips over due to carelessness or external circumstances. Risk of injury.
- Do not park the appliance on sloping floors.
- Secure the appliance against rolling away by applying both total locks when stopping it.
- In the case of off-site transport in a vehicle such as a lorry, secure the appliances properly. The total locks are not suitable for securing the appliances when they are transported in a vehicle.
- Heated appliances may only be operated by instructed specialists and kitchen staff and under continuous supervision.
- Powerstapler are intended for heating suitable heat-retaining base parts. They must not be used to cook food and keep it warm or to heat rooms.
- The temperatures can exceed the permitted maximum temperatures of 149°F (65°C) for touchable appliance surfaces. Always wear protective gloves when dispensing hot heat-retaining base parts. Risk of burning.
- Never reach into it and touch the heating element with the fingers when the appliance is in operation. Risk of burning.
- Plastic crockery items, top and bottom parts of plastic insulated sets and plastic-coated items for keeping food warm may not be stored nor warmed up in Powerstapler. The plastics can melt and catch fire due to the high temperature in the heating element.
- Before transporting, switch off the appliance using the on/off switch, pull out the mains plug and insert it into the holder provided.
- If you apply too much force on the connecting lead, this can cause damage to the lines inside the appliance. Risk of fire.
- Never pull the mains plug out of the socket by the lead. HUPFER® appliances in a standard design are equipped with a Schuko angle plug. Unlike a straight Schuko plug, this plug only projects slightly from the socket and so cannot be damaged by impact from the side. If the appliance is moved without pulling out the mains plug beforehand, the socket can be severely damaged or even pulled out from the wall as a result of leverage arising from overstretching of the connecting lead. The mains plug and the lead may also get damaged.
- Never move the appliance by pulling on the connecting lead.
- If the mains plug has come into contact with water, it must be dried before it is inserted into the socket. Danger to life.
- Damaged mains plugs or connecting leads are to be replaced by authorised specialist staff before the appliance is reused.
- Do not use any extension cables in wet and damp areas.
- Only insert mains plugs into suitable sockets. If the mains plug does not fit, the connecting lead of the appliance is to be retrofitted with a suitable plug by authorised specialist staff.
- The use of socket adapters is not permitted. Risk of fire.

2.4 Safety Instructions for Cleaning and Care

The following aspects must be taken into account when performing any cleaning and care tasks:

- Cleaning instructions must be strictly observed for reasons of hygiene.
- Take the appliance out of operation before starting the cleaning process. Pull out the mains plug and place it into the holder located on the appliance.
- For cleaning, the appliance must be out of operation and cooled down sufficiently.
- Do not clean the appliance with steam-jet or high-pressure cleaners. The appliance must be taken out of operation and switched off at the mains beforehand in any area where high-pressure steam or pressure washers are to be used.
- Even appliances without an electrical connection should not be cleaned with running water or pressurised water.

2.5 Safety Instructions Regarding Fault Repair

The following points shall be observed when carrying out any maintenance or fault repairs:

- Any fault repairs may be carried out by authorised specialists only.
- Ensure that the appliance is switched off when carrying out repairs. The appliance must be switched off at the mains and secured against reactivation when working on the electrical system.
- For troubleshooting, the appliance must be out of operation and cooled down sufficiently.
- The local Accident Prevention Regulations in force must be observed.
- Only use original spare parts to replace defective components.

2.6 Notes on Specific Hazards

Electric power

- All work on the electrical installations may only be carried out by a qualified electrician or by authorised specialists under the supervision and monitoring of a qualified electrician according to the applicable electro-technical regulations.
- The appliances on which inspection, maintenance and fault repairs are performed must be disconnected from the power supply and secured against reactivation when power is not required for such work. This may only be carried out by a qualified electrician.

3 Description and Technical Data

3.1 Performance Description

Powerstapler are mobile appliances intended for heating and dispensing wax-filled heat-retaining base parts in large-scale catering establishments.

Powerstapler accommodate heat-retaining base parts for plates with a diameter of 10.24" (260 mm) on a spring-loaded stacking platform. Owing to the use of special springs, the constant transport over the entire lift is guaranteed. Thus, inserted items can always be taken out at a constant dispensing height.

Powerstapler can also be used as plate dispensers for storage of heated or non-heated crockery with a nominal diameter of 10.24" (260 mm).

All appliances can be cleaned quickly and thoroughly from the top of the stacking compartment. The power module as well as electrical parts are easy to be accessed in case of service.

3.2 Proper Use

Powerstapler are intended for heating and dispensing wax-filled heat-retaining base parts.

The appliances can also be used as plate dispensers for transport and storage of round crockery items made of porcelain or toughened glass.

Transport of other types of loads is not permitted.

Proper use includes observing specified procedures, compliance with the technical specifications and use of supplied or optional original accessories.

Any other use of the appliances is considered as unintended use.

3.3 Improper Use

Plastic crockery items, top and bottom parts of plastic insulated sets and plastic-coated items for keeping food warm may not be stored nor warmed up in Powerstapler. The plastics can melt and catch fire due to the high temperature in the heating element.

Use for cooking food or keeping it warm or for room heating is not permitted.

In no case may people sit or stand on the appliance or be transported on it.

No flammable or outgassing objects, objects with plastic items or foodstuff may be stored under the Powerstapler.

It is not permitted to load the Powerstapler with other loads than specified.

No liability is assumed and no warranty claims can be submitted for damages caused by improper use.

3.4 Appliance Description

3.4.1 View of the Appliance

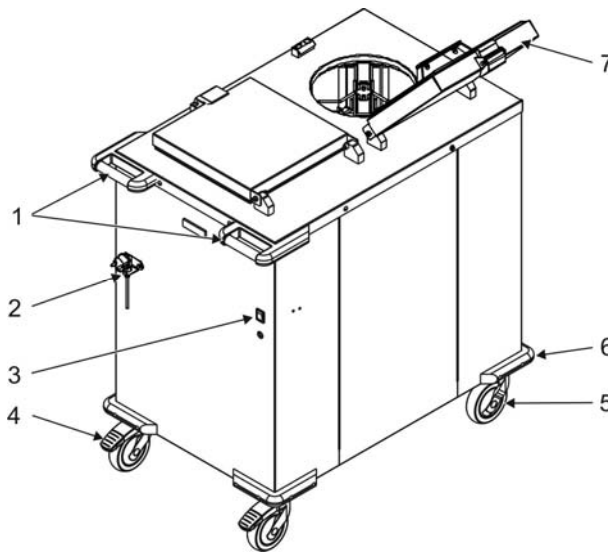

Figure 1 View of the appliance

- | | | | |
|---|----------------------------------|---|-----------------------------------|
| 1 | Push handles | 5 | Swivel casters without total lock |
| 2 | Connecting cable with mains plug | 6 | Corner bumpers |
| 3 | On/off switch | 7 | Cover |
| 4 | Swivel casters with total lock | | |

3.4.2 Appliance Description

The Powerstapler is made of stainless steel and is executed in self-supporting construction.

Two adjustable and spring-loaded stacking platforms accommodate heat-retaining base parts or clean porcelain plates or toughened glass. Special springs transport the inserted items towards the top at a constant speed across the entire lift, ensuring that the dispensing height always remains the same.

Ergonomically shaped push handles with an integrated bumper protect against injuries to the hands and damage to the appliance. Together with the corner bumpers fixed to the lower section they offer optimal collision protection in the direction of travel and guarantee an all-side protection against damage. Push handles and corner bumpers are made of high-quality, impact-resistant plastic.

An on/off switch with an integrated display function is fitted to the front of the housing. The operating mode can be easily seen from a distance because of the integrated light. The thermostat is set ex factory.

The appliance is insulated all-around by high-quality special insulation. The insulating plates are non-flammable, chemically neutral, damp-proof and harmless to health.

Two insulated covers made of stainless steel reliably protect inserted items from drying out, even during extended temporary storage periods. Covers reduce heat loss upwards and heating time. They are flat and double-walled and have a holding-down device made of plastic.

3.5 Technical Data

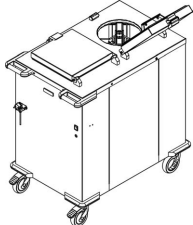
		Dim.
View of the appliance		
		
Powerstapler, heated with circulating air		
Tare weight	lbs (kg)	183 (83)
Payload	lbs (kg)	309 (140)
Gross vehicle weight rating	lbs (kg)	492 (223)
Overall dimensions w x d x h	in (mm)	24.8 x 39.1 x 40.9 (630 x 993 x 1037)
Chassis	in (mm)	4 swivel casters, 2 of them with total locks, Ø 5" (125 mm)
Crockery guide		4 stainless steel guides per stacking compartment, not adjustable, electropolished
Stacking platform	in (mm)	Stainless steel rod construction, electropolished
Stack height	in (mm)	23.2 (590)
Number of stacking compartments		2
Crockery	in (mm)	Wax-filled heat-retaining base parts for plates with a diameter of 10.24" (260 mm)
Capacity		approx. 84 heat-retaining base parts
Heating		Power module
Connected load	kW	1.84
Electrical connection		230 V 1N AC 50 Hz
Maximum pellet temperature	°F (°C)	266 (130)
Protection class		IPX 5
Heat insulation		Special insulation, 1.57" (40 mm) thick

You can find the corresponding certification marks on our homepage at www.hupfer.de.

3.6 Rating Plate

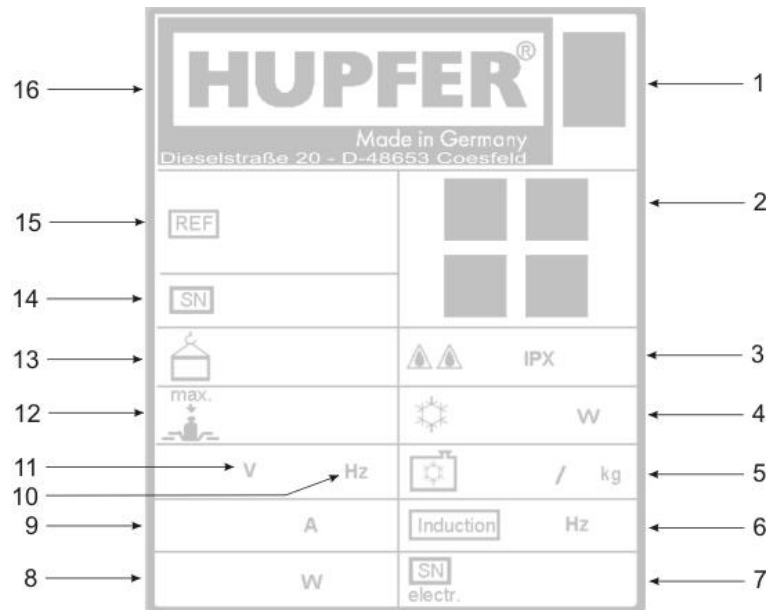

Figure 2 Rating plate

1	Disposal of old appliances	9	Nominal current
2	Certificates/label	10	Frequency
3	Protection class	11	Nominal voltage
4	Refrigeration capacity	12	Payload
5	Refrigerant	13	Tare weight
6	Induction frequency	14	Serial number/Order number
7	Electrical serial number	15	Item and brief description
8	Electric power	16	Manufacturer

4 Transport, Installation, Initial Operation and Taking out of Service

4.1 Transport

CAUTION



Damage to appliances caused by improper transport

Appliances should be safely secured when transported off site inside a vehicle such as a truck. The total locks are not suitable for securing the appliances when they are transported in a vehicle.

If the appliances are not secured properly, there is a risk of property damage and personal damage caused by squashing.

Secure each individual separate appliance using suitable transport securing devices.

4.2 Commissioning

Ensure that the appliance is clean and dry before putting it into operation. Before the first use of the appliance, remove the protective plastic film from the metal sheeting.

The following appliance functions must be checked before putting it into operation:

- In the mobile appliances: the functioning of the total locks.
- In the heated appliances: the functioning of the controls and heating.

INFO

Disposal of packing material

The packing consists of recyclable materials and can be disposed of accordingly. The different materials should be separated and disposed of in an environmentally friendly manner. The local agencies responsible for disposal must be contacted regarding removal

4.3 Storage and Recycling

Appliances must be kept in a dry, frost-free environment when placed in temporary storage. The Powerstapler must be kept covered with a suitable covering material to be protected against dust ingress.

The appliance kept in the storage location must be checked for damage and corrosion every 6 months.

NOTE

Condensation

Ensure that there is sufficient ventilation and no major variations in temperature in the storage location to prevent condensation from forming.

Before the appliance is taken back into operation, it must be clean and dry.

If the Powerstapler is recycled, all operating and auxiliary materials must be disposed in an environmentally compatible manner. Recyclable materials must be properly separated and disposed of in an environmentally compatible manner in accordance with local Waste Disposal Regulations. The local agencies responsible for disposal must be contacted regarding removal. Separate the reusable materials from the appliance (casters, plastic items, etc.) before disposing or send the appliance to a recycling centre. Dispose of the electronics at corresponding collection centres.

We offer our customers to dispose of their waste appliances. Please contact us or one of our distribution partners.

Packaging and packing material can be sent to the recycling centre by indicating the waste disposal contract number. If you do not have the valid waste disposal contract number, you can request it from [HUPFER® - Service](#).

5 Operation

CAUTION

Exposed springs



If the stacking platform is pressed down by hand, the springs are exposed. Reaching into the gaps of the exposed springs may cause hand injuries.

Never press the stacking platform down by hand.

Be careful when attaching and detaching the springs. Pay particular attention to the ends of the tension springs when adjusting springs on sharp edges.

5.1 Arrangement and Function of the Controls

CAUTION

Damage to property



The temperature settings set ex factory can be changed using the thermostat behind the panel on the right-hand side of the appliance.

Improper settings may cause damage to the appliance.

Making changes to the basic settings set ex factory requires sufficient knowledge of the design and functions, and changes may only be made by authorised personnel.

The controls of the Powerstapler are fitted on the front of the housing on the operating side.

An indicator light integrated into the on/off switch on the front side shows, whether the appliance is ready to for use.

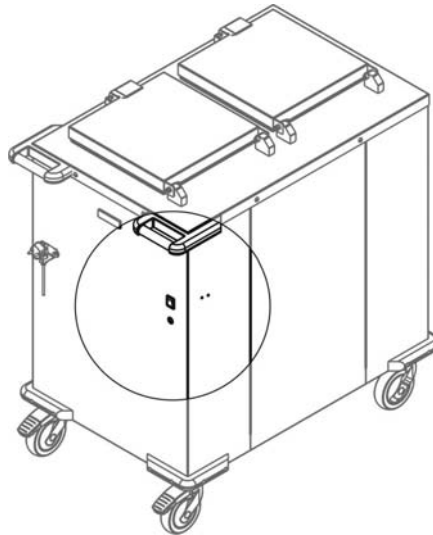

Figure 3

Controls

5.2 Adjustment of the Powerstapler

WARNING

Hazard caused by hot surfaces



The internal surfaces of the heated appliances and the base plates can become hot during use and cool down slowly in the air.

To adjust the stacking platform, allow the appliance to cool down sufficiently with open covers.

The adjustments may only be carried out on appliances which are switched off, disconnected from the power supply and cooled down (room temperature).

Before work starts, it is always necessary to check whether the Powerstapler is adjusted correctly for the items to be used.

Control the dispensing height to prevent the staff from suffering injury or become trapped and to prevent breakage of crockery can occur.

Basically, the appliance must be adjusted if at least one of the following parameters changes:

- Diameter
- Height
- Stack height
- Weight

5.2.1 Springs Adjustment

CAUTION

Personal and property damage due to improper adjustment



When the dispensing height is exceeded, there is a risk of accident or injury due to tipping of the inserted stacks. If the level of the stack falls below the dispensing height, fingers may be injured if caught when removing dishes.

Adjust appropriately the dispensing height by attaching or detaching the springs. When adjusting springs on sharp edges, pay particular attention to the ends of the tension springs. Proceed with care.

CAUTION

Risk of injury



Be careful when attaching and detaching the springs.

Pay particular attention to the ends of the tension springs when adjusting springs on sharp edges.

Before loading the appliance, the dispensing height must be adjusted to the type of crockery used. The dispensing height is adjusted by attaching or detaching tension springs. As long as the same kind of items is always used, the dispensing height only needs to be set once.

Step 1 – Check the adjustment of the springs

- Place a stack of heat-retaining base parts on the stacking platform to test the dispensing height.
- Wait for the system to self-adjust.

If the stack drops down only a little or not at all, the dispensing height must be altered by adjusting the springs.

Step 2 – Change the adjustment of the springs

The dispensing height is adjusted by attaching or detaching tension springs on four attachment bars. The springs are arranged in groups of five, where one is a base spring with higher tension (1) and four are adjustable springs (2) with lower tension.

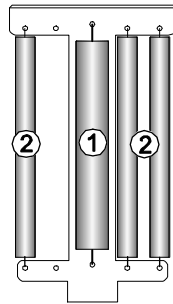

Figure 4 Attachment bar with tension springs (example)

If the dispensing height is too high, adjustable springs must be detached. If the dispensing height is too low, adjustable springs must be added.

Procedure for adjusting the springs:

- Remove inserted stacks from the stacking platform (if available).
- Attach or detach adjustable springs evenly in all groups of springs.
- It is best to detach the adjustable springs. Always leave the base springs inserted, if possible. Always detach the springs on the lower attachment bar.

As long as the same kind of items is always used, the dispensing height only needs to be set once.

NOTE

Arrangement of the springs

The springs need to be in a symmetrical arrangement between the attachment bars to ensure that the stacking platform is guided smoothly and steadily.

A slightly asymmetrical arrangement of springs within an attachment bar does not pose a problem.

NOTE

Spring system

Since Powerstapler are designed for a maximum load, the available spring system of the appliances is entirely sufficient for all usual stack items.

5.2.2 Calculating the capacity for Powerstapler

The total capacity of a Powerstapler depends on the items loaded.

All leading manufacturers provide the necessary data for calculating the intermediate stack height in the following way:

$$H_z = \frac{(H_n - H_1)}{n-1}$$

H_z : Intermediate stack height

H_1 : Height of the first item

H_n : Height of n items

n: Number of items

The capacity per crockery stack can be calculated together with the stack height H_s of the Powerstapler:

$$K = \frac{(H_s - H_1)}{H_z} + 1$$

K: Items per stack

H_s : Stack height of the Powerstapler

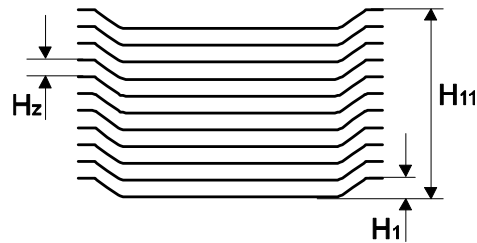

Figure 5 Intermediate stack height H_z for 11 items

Example:

$$H_z = \frac{(140 - 28)}{10} = 11,2 \text{ mm}$$

$H_1 = 1.1''$ (28 mm): Height of the first item

$H_{11} = 5.5''$ (140 mm): Height of 11 items

$t = 11$: Number of items

$H_s = 24.6''$ (625 mm): Stack height

$$K = \frac{(625 - 28)}{11,2} + 1 = 54 \text{ Teile}$$

The capacity of one stacking platform in this example is 54 stacked items.

5.3 Operation

Before the appliance is put into operation it must be clean and dry.

Before work starts, it is always necessary to check whether the Powerstapler is adjusted correctly for the items to be used.

The correct dispensing height must be ensured to avoid that the staff suffers injury or becomes trapped and no breakage of crockery occurs.

Use of the cover

CAUTION

Risk of injury



If a stack is too high, do not use the covers to push the stack down forcibly. There is a risk of injury if the locking is released.

NOTE

Use of the cover

The cover ensures effective protection against ingress of dust and condensation even during relatively long periods of temporary storage. Closing the cover of the heated appliances lowers the heat loss upwards and reduces the heating time of the inserted items or delays the cooling of pre-heated items.

Switching on the appliance

DANGER

Hazardous electrical voltage



Electrical current can pose a considerable threat to life and physical well-being and may lead to injuries.

Only use the plug connection provided for this purpose. The appliance may not be operated if the connecting lead is damaged or any other damage is visible.

All work on the electrical installations may only be carried out by a qualified electrician or by authorised specialists under the supervision and monitoring of a qualified electrician according to the applicable electro-technical regulations.

- Close the covers to avoid heat loss.
- Switch off the appliance with the on/off switch if necessary.
- Insert the mains plug into a suitable socket.
- Switch on the appliance using the on/off switch. The indicator integrated into the switch will light up to show when the appliance is ready for use.

Loading the appliance

CAUTION

Risk of fire



Plastic crockery items, top and bottom parts of plastic insulated sets and plastic-coated items for keeping food warm may not be stored nor warmed up in Powerstapler. The plastics can melt and catch fire due to the high temperature in the heating element.

Only use appropriate heat-retaining base parts released by **HUPFER®**.

NOTE	Loading
<p>Before the stacks are inserted, the crockery guide and the stack height must be set correctly.</p> <p>Insert the items individually or in small safely manageable stacks.</p> <p>The marking for the maximum stack height must not be exceeded.</p>	

- Place the first heat-retaining base parts on the centre of the stacking platform and lower them slowly.
- Put further items precisely onto the heat-retaining base parts already placed in the appliance.
- Briefly press down the entire stack once the marking for the maximum stack height has been reached.

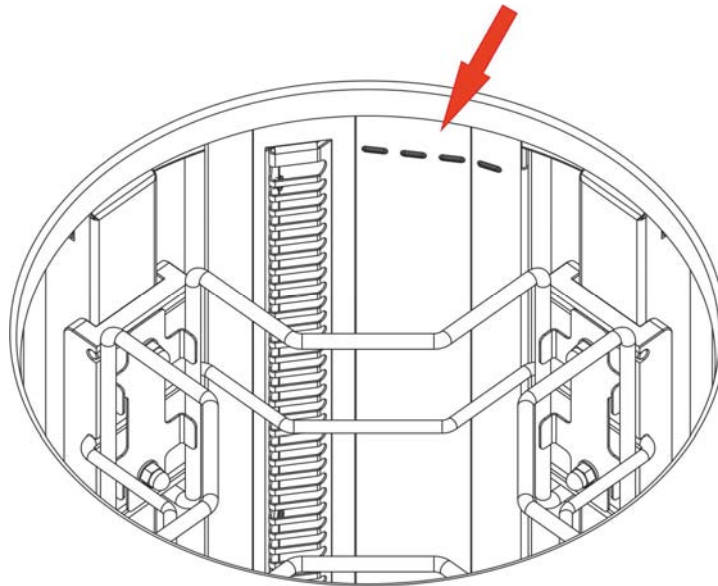



Figure 6 Fill level marking

- Then close the covers.

NOTE	Heating time
<p>Completely filled Powerstapler need approx. 3 h to heat up the heat-retaining base parts to 130 °C.</p>	

Unloading crockery

WARNING	Risk of burning
	<p>In the heated appliances the temperatures can exceed the permitted maximum temperatures of 65°C for touchable appliance surfaces.</p> <p>Never reach into the appliance or touch the heating element with fingers during use. Always wear protective gloves.</p>

- Open the cover.
- Remove the heat-retaining base parts.
- Close the cover again.

Moving the appliance

- Switch off the appliance with the on/off switch.
- Pull out the mains plug and insert it into the plug park provided.
- Release both total locks.
- Take hold of the push handles on the appliance and move the appliance to its destination.
- Once at its destination, apply both total locks, so the appliance isn't moved by accident.
- Insert the mains plug into a suitable earthed socket.
- Switch on the appliance using the on/off switch.

5.4 Measures at the End of Use

WARNING

Hazard caused by hot surfaces





The internal surfaces of the appliance and the base plates may become hot during use and will only cool down slowly in the air.

Allow the appliance to cool down sufficiently with open covers and wear suitable protective gloves.

-
- Once at its destination, apply both total locks, so the appliance isn't moved by accident.
 - Switch off the appliance with the on/off switch.
 - Pull out the mains plug and insert it into the plug park provided.

6 Troubleshooting and Repair

6.1 Safety Measures

DANGER	Hazardous electrical voltage
	<p>Electrical current can pose a considerable threat to life and physical well-being and may lead to injuries.</p> <p>Switch off the appliance at the mains before performing troubleshooting. Pull out the mains plug and insert it into the plug park provided.</p>
WARNING	Hazard caused by hot surfaces
	<p>The internal surfaces of a heated appliance and the base plates can become hot during operation and only cool down slowly in the air.</p> <p>In the event of a malfunction, allow the appliance to cool down with the cover removed; wear suitable protective gloves.</p>
CAUTION	Exposed springs
	<p>If the stacking platform is pressed down by hand, the springs are exposed. Reaching into the gaps of the exposed springs may cause hand injuries.</p> <p>Never press the stacking platform down by hand.</p> <p>Be careful when attaching and detaching the springs. Pay particular attention to the ends of the tension springs when adjusting springs on sharp edges.</p>

6.2 Instructions regarding Fault Repair

Please check first whether there is an operating fault. You can repair some faults yourself.

Servicing may be carried out by authorised specialists only. Indicate the information given on the rating plate if you contact the after-sales service or order spare parts.

Only use original spare parts to replace defective components.

Regular inspection and maintenance of the appliance prevent disruptions to operations and ensure safety. Inspection and maintenance intervals depend on the use of the appliance. Consult your dealer's after-sales service department.

6.3 Fault and Action Table

Fault	Possible cause	Remedy
Appliance does not become warm; indicator light does not come on.	Defective building fuses.	Check fuse and repair if necessary.
Appliance does not become warm; indicator light does not come on.	Defective on/off switch.	Disconnect the appliances from the mains and have it checked and repaired by authorised technical staff if necessary.
Appliance does not become warm; indicator light does not come on.	Defective connecting lead or mains plug	Disconnect the appliances from the mains and have it checked and repaired by authorised technical staff if necessary.
Appliance does not become warm; indicator light is on.	Defective circuit, thermostat or heating.	Take the appliance out of operation and have it checked and repaired by authorised technical staff if necessary.

Fault	Possible cause	Remedy
Appliance does not become warm; indicator light is on.	Safety temperature limiter triggered.	Take the appliance out of operation and have it checked and repaired by authorised technical staff if necessary.
Appliance becomes warm; indicator light does not come on.	Defective indicator light.	Take the appliance out of operation and have it checked and repaired by authorised technical staff if necessary.
Stacking platform does not move plates upwards to the dispensing height even with a low load.	Spring broken.	Replace defective springs with new ones.
Total locks no longer brake.	Total locks have worn down.	Either replace the total locks or replace the defective casters.
Heat-retaining base parts are not becoming hot.	Cover not closed and locked correctly.	Close and lock cover.
Heat-retaining base parts are not becoming hot.	Damaged seal on the cover.	Replace seal.

7 Cleaning and care

7.1 Safety Measures

DANGER

Hazardous electrical voltage



Electrical current can pose a considerable threat to life and physical well-being and may lead to injuries.

Before cleaning, switch off the appliance at the mains. Pull out the mains plug and insert it into the plug park provided.

WARNING

Hazard caused by hot surfaces



The internal surfaces of the appliance and the base plates may become hot during use and will only cool down slowly in the air.

For cleaning, allow the appliance to cool down with the cover removed and wear suitable protective gloves.

CAUTION

Exposed springs



If the stacking platform is pressed down by hand, the springs are exposed. Reaching into the gaps of the exposed springs may cause hand injuries.

Never press the stacking platform down by hand.

Be careful when attaching and detaching the springs. Pay particular attention to the ends of the tension springs when adjusting springs on sharp edges.

CAUTION

Do not clean with running water



The appliance should not be cleaned with running water, or steam-jet or high-pressure cleaners. The appliance must be taken out of operation and switched off at the mains beforehand in any area where high-pressure steam or pressure washers are to be used.

7.2 Hygiene Measures

It is essential for operating staff to act in the correct manner to ensure optimal hygiene.

Everyone must be informed about local applicable hygiene regulations, observe them and comply with them.

Use a waterproof plaster to cover wounds on hands and arms.

Never sneeze or cough on clean crockery.

7.3 Cleaning and care

The appliance must be cleaned dry daily or wiped with a damp cloth. Dry the appliance thoroughly after cleaning with damp materials to prevent mould forming, germs and bacteria spreading unchecked and, consequently, crockery from being contaminated.

The objects that have fallen down into the appliance can be removed by means of gripping tongs.

7.4 Special Care Instructions

Resistance to corrosion in stainless steel is provided by a passive layer which is formed on the surface when oxygen is absorbed. The oxygen in air is sufficient to form the passive layer, so that damage caused by physical action is eliminated automatically.

The passive layer develops or is renewed more quickly when the steel comes into contact with water containing oxygen. The passive layer can be chemically damaged or breached by agents which have a reducing (oxygen-consuming) effect when they come into contact with steel at concentrated levels or at high temperatures.

Such aggressive substances include:

- substances containing salt and sulphur
- chlorides (salts)
- seasoning concentrates (e.g. mustard, vinegar essence, seasoning cubes, saline solutions)

Further damages can occur due to:

- extraneous rust (e.g. from other components, tools or rust film)
- iron particles (e.g. grinding dust)
- contact with non-ferrous metals (element formation)
- lack of oxygen (e.g. no admission of air, low-oxygen water).

General working principles for handling appliances made of "refined stainless steel":

- Always keep the surface of appliances made from stainless steel clean and open to air.
- Use cleaning agents suitable for stainless steel. Never use bleaching cleaning agents or any containing chlorides.
- Remove layers of lime scale, grease, starch and egg-white by cleaning daily. Corrosion may occur underneath these layers due to lack of air absorption.
- Once the appliance has been cleaned, remove all cleaning agent residues by wiping thoroughly with plenty of water. The surface should be thoroughly dried after wiping.
- Do not bring items made of stainless steel into contact with substances such as concentrated acids, seasonings and salts for longer than is absolutely necessary. Acid fumes emitted when tiles are cleaned also cause corrosion in "refined stainless steel".
- Avoid damaging the surface of the stainless steel, especially by bringing into contact with metals other than stainless steel.
- Residues from other metals produce extremely small amounts of chemical elements which can cause corrosion. Contact with iron and steel must be avoided at all costs, because it will cause extraneous rust. If stainless steel comes into contact with iron (steel wool, steel particles from pipes, water containing iron), this can trigger corrosion. Therefore, only use refined steel wool or brushes with natural, plastics or refined steel bristles only for physical cleaning. Steel wool or brushes with unalloyed steel cause extraneous rust due to abrasion.

8 Spare Parts and Accessories

8.1 Introduction

Servicing may be carried out by authorised specialists only.

Only use original spare parts to replace defective components.

Always specify the information and corresponding part number indicated on the rating plate when contacting the after-sales service or ordering spare parts.

8.2 Spare Parts and Accessories List

Spare part, item code	Item designation	Type	Qty.
014000402	Swivel caster with total locks	Ø125 mm (4.92"), screw plate	
014000401	Swivel caster	Ø125 mm (4.92"), screw plate	

Following plug types can be used with Powerstapler:

- 2-pole Schuko angle plug (standard)
- CEE plug 230 V - 16 A / 6 h / 3-pole in Germany on request, in Switzerland standard
- 3-pole British mains plug in accordance with BS 1363 A for Great Britain and Hong Kong

9 Annex

9.1 EC Declaration of Conformity

EG-Konformitätserklärung

Declaration of CE-Conformity | Déclaration de conformité CE

Gegenstand | Object | Objet

Tellerstapler, Tassenstapler, Powerstapler elektr. | plate dispenser, cup dispenser, Powerstapler, electr.
| chariot niveau constant assiettes, chariot niveau constant à tasses, Powerstapler, élect.

Typ | Type | Type

TEH / TEUH / EBRH / SPTW/TEHCO / PSUH

Es wird bescheinigt, dass das/die zuvor näher beschriebene/n Produkt/e der/den im Folgenden aufgelisteten EU-Richtlinie/n entspricht/entsprechen:

2006/42/EG, 2006/95/EG, 2004/108/EG

Darüber hinaus wurden folgende harmonisierte Normen angewandt:

EN ISO 12100:2010, EN 60204-1:2006, EN 61000-6-2, EN 61000-6-4, EN ISO 13857

Im Übrigen wird bescheinigt, dass das/die Produkt/e weder Störungsquellen noch störungsanfällige Bauteile im Sinne der EMV-Richtlinie enthält/enthalten.

It is certified that the product/s described in detail before, conform/s to the requirements of the European Union directive/s listed in the following:

2006/42/EC, 2006/95/EC, 2004/108/EC

Furthermore, the following harmonised standards have been applied:

EN ISO 12100:2010, EN 60204-1:2006, EN 61000-6-2, EN 61000-6-4, EN ISO 13857

Incidentally, it is certified that the product/s contain/s neither sources of disturbance nor components liable to disturbances according to the EMC directive.

Il est certifié que le/s produit/s décrit/s en détail ci-dessus, correspond/ent aux directive/s de l'UE énuméré/es dans ce qui suit:

2006/42/CE, 2006/95/CE, 2004/108/CE

En outre, les normes harmonisées suivantes ont été appliquées:

EN ISO 12100:2010, EN 60204-1:2006, EN 61000-6-2, EN 61000-6-4, EN ISO 13857

Il est certifié aussi, que le/s produit/s ne contient/contiennent ni des sources de perturbation ni des éléments de construction exposés à des perturbations correspondant aux directives de l'AECM.

Coesfeld, 12.08.2015

Helmut Schumacher Vorname Nachname	Geschäftsführung Position	Unterschrift
----------------------------------------------	-------------------------------------	--------------

Egbert Flück Vorname Nachname	Betriebsleiter / Konstruktionsleiter Position	Unterschrift
-----------------------------------------	---------------------------------------------------------	--------------

Dokumentationsbevollmächtigter Holger Michels	HUPFER® Metallwerke GmbH & Co. KG	info@hupfer.de
---------------------------------------------------------	--------------------------------------	----------------

Diese Konformitätserklärung ist eine original Konformitätserklärung in deutscher Sprache und kann gleichlautende Übersetzungen in weiteren EU-Sprachen enthalten. This declaration of conformity is an original declaration of conformity in the German language and can contain identical translations in the other EU languages. Cette déclaration de conformité est une déclaration de conformité originale en langue allemande et peut contenir des traductions conformes en d'autres langues de l'UE.

HUPFER® Metallwerke GmbH & Co KG
Dieselstraße 20 | 48653 Coesfeld | Deutschland | +49 2541 805-0 | info@hupfer.de

