

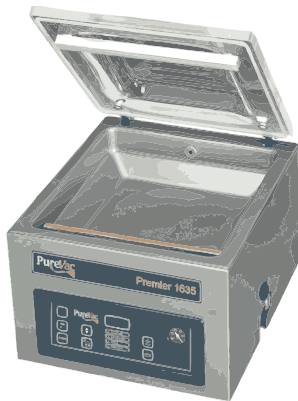

USER MANUAL

PREMIER & ULTRA SERIES



1800 035 327
www.comcater.com.au
from the world of Comcater



This manual is for the PREMIER AND ULTRA series. The general instructions apply to the models in this category. PureVac cannot be held responsible for any damage caused by deviating machine specifications.

This manual has been compiled with the utmost of care. PureVac accepts no responsibility for any errors in this manual and/or the results of misinterpretation of this manual.

PureVac is not liable for damages and/or problems that arise from using spare parts that are not supplied by PureVac

PureVac reserves the right to change specifications and/or spare parts without prior notification.

All rights reserved. No part of this publication may be reproduced by photocopy, printing or in any other way without prior consent from PureVac

LIABILITY

1. We exclude all liability in so far as it is not provided for by law.
2. Our liability shall never exceed the total amount of the order in question.
3. Barring the generally applicable legal rules of public order and good faith we are not liable to pay for any damage of any sort whatsoever, directly or indirectly, including business losses, to movable or immovable property, or to persons, either at the opposing party as at third parties.
4. We are in any case not liable for damages arising from or cause by the use of the product supplied or by the unsuitability of it for the goal for which the other party purchased it.

GUARANTEE

1. Subject to the following limitations we give 24 months guarantee on the products supplied by us. This guarantee is limited to manufacturing faults that occur and does therefore not cover breakdowns involving any parts of the supplied product that are exposed to any form of wear or usage.
2. The guarantee on parts or additions provided from third party suppliers is limited to the guarantee provided us by the third party supplier.
3. The guarantee expires if the other party and/or third parties engaged by him use the supplied product incompetently.
4. The guarantee also expires if the other party and/or third parties engaged by him carry out activities on i.e. make modifications to the supplied product.
5. If we replace parts in compliance with the obligations of this guarantee then the replaced parts become our property.
6. If the other party does not, not sufficiently, or not in a timely fashion fulfil any of the obligations arising from the agreement reached between the parties then we are not obliged to provide this guarantee as long as the situation is occurring.

The stipulations of the guarantee and liability are part of the general terms and conditions of sale which will be sent to you if requested.

CONTENT USER MANUAL

INTRODUCTION / LIABILITY / GUARANTEE	2
CONTENTS INSTRUCTION MANUAL	3
MACHINE REGISTRATION	4
IMPORTANT FOR INSTALLATION – READ THIS FIRST!!!!	5
IMPORTANT FOR USE – READ THIS FIRST!! !!	7
WARNING LABELS	8
IMPORTANT MACHINE PARTS	7
STARTING UP AND OPERATING	8
	ON/OFF switch / Master switch	8
	Sleeper function	8
	Start machine	8
	Standard operating steps	9
MACHINE CONTROL PANEL	10
	Control panel versions	10
	Control panel layout	11
	Operation mode	12-14
	Program mode	14
	Other modes	14
	Operation Hours Counter	14
PROGRAMMING	15
	Manual programming	15
	Automatic programming	16
	Special remarks on programming	17
MACHINE MAINTENANCE	18
	General	18
	Important before and during maintenance ...	18
	Standard maintenance schedule	19
	Vacuum pump maintenance	19
	Conditioning Program	19
	Changing Oil / Filing up	20
	Changing the oil filter	21
	Inspect and change oil exhaust filter	21-22
	Seal system maintenance	22-23
	Silicone holder and lid gasket maintenance ...	24
	List of maintenance parts	25
TECHNICAL SPECIFICATIONS	26
ELECTRICAL DIAGRAMS	27-28
ERRORS CODES	29
PNEUMATIC DIAGRAMS	29
PROBLEM SOLVING	30
FACTORY SETTINGS CONTROL	31
REMARKS ON SPECIAL APPLICATIONS	32
	Machine with gas flush system	32
	Packaging liquid products	32
	External vacuuming of food containers	33
MAINTENANCE SCHEDULE / NOTES	34
REMOVAL FRONT PANEL	35



PRIOR TO STARTING TO USE THE MACHINE, MACHINE REGISTRATION TO BE COMPLETED BY THE USER

Register the machine using the following data. This information is necessary if the supplier or PureVac is contacted concerning questions or references about the specific machine.

DATA ON MACHINE TAG

Relevant data for answering questions can be found on the machine tag. The machine tag is located at the rear of the machine. Note down the following data:

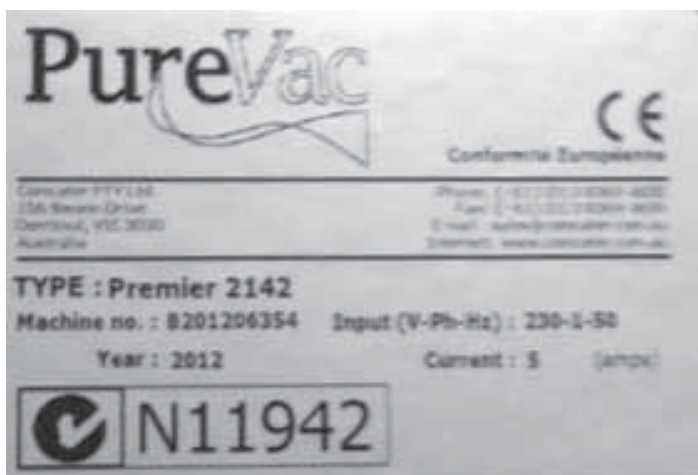

1. MACHINE TYPE

2. MACHINE NUMBER (MACHINE NO.)

3. VOLTAGE (TENSION)

CONTROL PANEL DATA

When starting the machine, two codes first appear on the large display in succession before control panel switches to operation mode. The first code indicates the model of the machine and the second code indicates the control software version.

Write both codes in the space below:



4. CODE 1

5. CODE 2



IMPORTANT FOR INSTALLATION !!! READ THIS FIRST !!!

GENERAL

- First read this manual carefully before the machine is put into operation.
- This manual contains relevant information and instructions for starting up, maintenance and applications.
- If problems arise with the machine that could have been avoided by referring to this manual then the guarantee expires.
- PureVac wishes the customer lots of pleasure for an extended period from the purchase of the machine. If there are any problems or questions then the customer can always approach the supplier or PureVac.

ENVIRONMENT

- The machine must be moved or transported in an upright position. The machine may NOT be tilted as this can cause damage to the pump.
- Place the machine on a flat, level floor. This is essential for problem free operation of the machine.
- Enough space must be left around the machine for good ventilation. The space must be at least 5 centimetres.
- The ambient temperature in which the machine is operated must be between 5 0C and 30 0C. When operating the machine in other ambient temperatures the user must contact the supplier or PureVac for advice.
- NEVER place the machine directly next to a heat source or a steaming device (for example a combo-steamer, dishwasher or stove)

POWER / EARTH

- Check that the voltage stated on the machine tag is the same as the mains voltage.
- Check the direction which the pump is turning when the machine is connected to a three phase power source.
- Always connect the machine correctly to an earthed socket to avoid danger for fire or electrical shocks (earth connection is green/yellow).
- The power cable must always be free and nothing may be placed on it.
- Replace the power cable immediately if damaged.
- Always disconnect the power if there are problems with the machine or during maintenance, prior to starting work on the machine.
- If the machine is stationary for long periods then the power should always be disconnected..

VACUUM PUMP

- Check before starting the machine if there is oil in the pump (see page 20). NEVER start the machine without oil in the pump.
- Use the right type of oil for the pump (see page 21).
- After moving and/or transporting the machine, always first check the oil level before re-starting operation.
- When starting the machine for the first time or after a lengthy idle period first run the conditioning programme before operating the machine (see page 19).

CONNECTING THE GAS FLUSH SYSTEM (if applicable)

- NEVER use flammable gasses or gas mixtures containing too much oxygen. There is a danger of explosion when using the aforementioned gasses. Accidents and/or damage caused by using abovementioned gasses void all liability on the part of PureVac as well as the guarantee.
- The gas bottles must always be correctly secured. If the gas flush function and/or the machine is not in use then the main cock of the gas bottle must always be closed.
- The pressure of the pressure reducing valve on the gas bottle may NEVER be set to more than 1 atmosphere/ATO. A higher pressure may damage the machine.
- The diameter of the hose nipple connector for the gas bottle is 6 mm (Premier Series), and 8 mm for other machines. The connector is at the rear of the machine.

For more information about the use of gas bottles, consult an authorised gas supplier

CONNECTING COMPRESSED AIR FOR EXTERNAL SEALING PRESSURE (if applicable)

- The pressure from the compressor may NEVER be set to more than 1 atmosphere/ATO. A higher pressure may damage the machine.
- Only dry compressed air may be used for the external seal pressure.
- The diameter of the hose nipple connector the compressor is 6 mm (rear machine)

For more information about the use of compressed air, consult an authorised gas supplier



IMPORTANT FOR OPERATION !!! READ THIS FIRST !!!

GENERAL

- Never pack products that can be damaged during or after vacuum packaging. Live oats may never be vacuumed.
- Refer to this manual if in doubt as to the operation and/or functioning of the machine. If the manual does not offer a solution consult the supplier or PureVac.
- The guarantee and/or liability expires if damage is caused by repairs and/or changes made by you. In the case of malfunctions contact the supplier or PureVac.
- In the case of malfunctions always stop the machine and remove the power cable from the wall socket.

GENERAL MAINTENANCE

- It is essential that the machine is serviced regularly to guarantee operation and to keep the machine in optimal condition. The maintenance schedule is clearly defined on page 12. The guarantee automatically expires due to overdue or sloppy maintenance.
- Always remove the power cable from the wall socket for maintenance work, the machine must be completely disconnected.
- If there are doubts about the maintenance activities or if the machine fails to work correctly always contact the supplier or PureVac.

TRANSPARENT LID

- Never locate the machine near a heat source. This can cause damage to the lid (cracks).
- Never place hot, sharp, or heavy objects on the lid. These can cause damage to the cover (cracks) in the long run.
- Always clean the cover with solvent-free cleaning agents. Solvents can damage the lid.
- Check at least once a week if there are cracks in the lid. If cracks are visible in the lid then the machine must IMMEDIATELY be turned off and not used again until the lid has been replaced. Continuing to work with a cracked lid can cause the lid to implode. All guarantees and/or liability expire in the case of accidents and/or damage caused by working with a cracked lid.
- Replace the transparent cover every 4 years as a precautionary measure as a standard maintenance interval.

VACUUM PUMP

- Regularly check the level and quality of the oil in the pump. If too little oil or the quality of the oil is bad (turbid), replace or top up the oil before operating the machine (see page 20). Let the pump conditioning program run at least one full cycle before replacing the oil (see page 20).
- Use the right type of oil for the pump when replacing or topping up (see page 20).
- Use the conditioning program at least once a week to enhance correct and long-lasting pump operation (see page 19).

USE OF GAS FLUSH SYSTEM (if applicable)

- NEVER use flammable gasses or gas mixtures containing too much oxygen. Use thereof can cause risk of explosions. Accidents and/or damage caused by using abovementioned gasses voids all liability on the part of PureVac as well as the guarantee.
- The gas bottles must always be correctly secured. If the gassing function and/or the machine is not in use then the main cock of the gas bottle must always be closed.
- The pressure of the pressure reducing valve on the gas bottle may NEVER be set to more than 1 atmosphere/ATO. A higher pressure may damage the machine.

For more information about the use of gas bottles, consult an authorised gas supplier



WARNING SIGNS ON THE MACHINE !!!



- ONLY use the prescribed power supply voltage.
- Insert the plug firmly into the mains wall socket.
- Always connect the machine to an earthed wall socket.
- Always remove the plug during maintenance or when the machine is not in use for extended periods.



- NEVER use flammable gasses or gas mixtures containing too much oxygen. Use thereof can cause risk of explosions
- Accidents and/or damage caused by using abovementioned gasses void(s) all liability on the part of PureVac as well as the guarantee.

IMPORTANT MACHINE PARTS



Vacuum chamber



Side view Premier Series

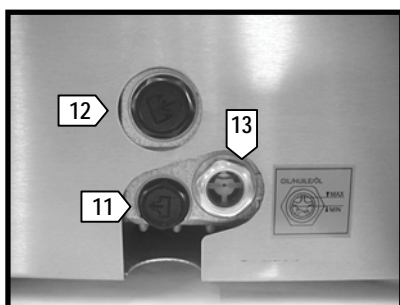

Rear view Premier Series

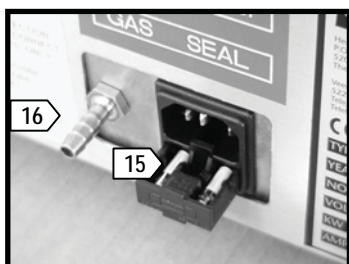
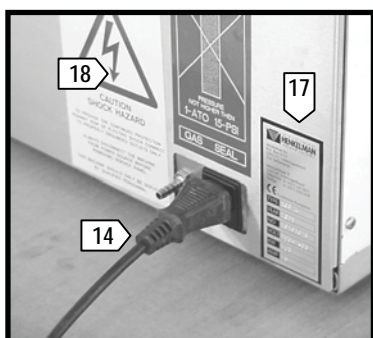

Rear view Ultra Series

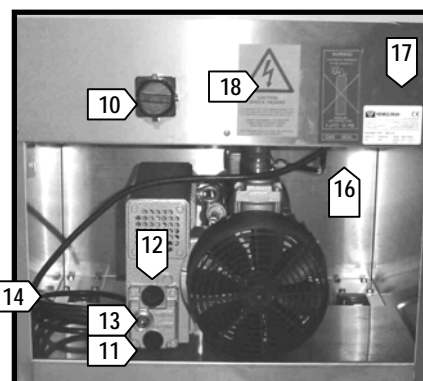

1. Sealing bar(s) in vacuum chamber mounted seal pots with a click system
2. Silicone holder(s) mounted on transparent lid
3. Gas flush nozzles (if applicable)
4. Lid rubber in lid for hermetic seal
5. Gas springs for opening lid after machine cycle
6. Vacuum / Ventilation opening
7. Control panel
8. Vacuum pressure meter
9. ON/OFF Switch
10. Master switch (only Ultra series)
11. Oil drain plug
12. Oil fill plug
13. Oil inspection window
14. Power cable
15. Fuse holder with fuse (only Premier series)
16. Gas bottle connector (if applicable) caution max 1 Bar
17. Machine tag
18. Warning stickers

Appearance of parts and machines can deviate from illustrations

STARTING AND OPERATING THE MACHINE

ON/OFF SWITCH / MASTER SWITCH



The ON/OFF switch is used to turn the machine on and off before and after operation.

CAUTION – The ON/OFF switch does not completely turn off all power to the machine. With the Premier series, and other models which run on 1 phase power, it is necessary to unplug the power cable from the wall socket before the machine is completely without power. With the other Ultra models which run on 3 phase power, it is necessary to turn off the master switch before the machine is completely without power. Ensure that the machine is completely without power during maintenance and repair activities.



Premier series

When the machine is turned on (with the ON/OFF switch), the pump only runs during the vacuum cycle.

Ultra series

When the machine is turned on (with the ON/OFF switch), the pump runs continuously. The 3 phase pumps need more time to warm up and turning them on and off has a detrimental effect on their lifespan. If the machine is turned on, but it is not used, the pump will automatically turned off after 10 minutes. This to prevent overheating from the oil, and reduce unnecessary pollution from exhaust filters. We call this function Sleeper function.

SLEEPER FUNCTION

On the models: Ultra the sleeper function id default switched on. This means if the machine is switched on but not ued, the pump automatically switches of after 10 minutes. By closing the lid the cycle and the pump will start simultaneously. Contact the supplier or PureVac for more information on the sleeper function.

START MACHINE

When the machine is connected and the master switch is switched to 1 (if applicable) then the machine can be turned on using the ON/OFF switch. When starting the machine two codes first appear in succession on the large display before control panel switches to operation mode.

The first code indicates the model of the machine. The second code indicates the control software version. Note both codes on page 4 as they are important for the supplier or PureVac when making enquiries and/or if any problems arise.



After switching to operation mode the machine is ready for use. If the machine is new or has been unused for a longer period of time then it is advisable to run the pump conditioning program (15 minutes) to heat up and clean the pump. For instructions on the conditioning program, see page 19.



After switching to the operation mode the display could read [OIL]. This means that the operating hours counter is turned on and the set number of operating hours has elapsed. The hour counter is turned off by default but the client or supplier can activate it as a reminder for regular maintenance activities.

When [OIL] is displayed the machine can be still be used as usual but it is advisable to either turn off the hour counter or to reset it. More information on how to set or turn off the operating hours counter can be found on page 14.



STANDARD USER OPERATIONS FOR THE MACHINE

1. Turn the machine on with the ON/OFF switch. Heat up the pump with the condition program when machine has stood idle for some time (instructions page 22).
2. Fill the vacuum bag with product. Select the correct format bag that easily fits around the product but is not too large for the product. Ensure hygienic conditions during this operation. Packaging materials, product and hands must be clean and if possible dry.
3. Lay the vacuum bag in the chamber or on the working plate. The open side must be laid over the sealing bar or silicone holder. The bag may however not extrude from the chamber. If the product is a lot lower than the height of the sealing bar or silicone holder then insertplates which are supplied standard with the machine can be used. This makes the operation easier and reduces the cycle time.
 
4. The vacuum bag must be laid without folds over the sealing bar (Premier and Ultra)
5. For a gas flush system the opening of the vacuum bag must be pulled over the gas nozzles (see illustration).
6. Multiple vacuum bags can be placed over the sealing bar/silicone holder if the sealing bar/silicone holder is longer than the vacuum bag. Vacuum bags may not however be laid on top of each other on the bar/holder. If there are multiple bars/holders then all bars/holders can of course be used during the same cycle.
7. Use the [PROG] key to choose the desired program. See page 15 for instructions about programming.
8. Close the lid and the machine automatically runs through the full cycle of all activated functions. The lid opens automatically when the last function "ventilation" has been completed.
9. If necessary the cycle can be partially or fully interrupted by pressing the [VACUUM STOP] key or the [STOP] key. The [VACUUM STOP] key interrupts the active function (vacuum, gas flushing, sealing, or soft-air ventilation) and automatically continues with the next function. The [STOP] key interrupts the entire cycle and goes immediately to the ventilation function.
10. After cycle completion, the packed product (or products) can be removed from the machine.
11. If the machine is equipped with a cut-off sealing system then the remaining flap on the vacuum bag can be torn off.



SAFETY and PRODUCT PROTECTION

The packing process can be partially or fully interrupted at all times:

- Stop active function, press on [VACUUM STOP] key
- Stop full machine cycle, press [STOP] key

OPTIMAL AND EFFICIENT PACKAGING RESULT

- Use the correct size and good quality vacuum bags
- Maximum 75% product filling in vacuum bag
- Place vacuum bag fold free over sealing bar/silicone holder (use correct number in insertplates in chamber)
- Pull vacuum bag far enough over gas nozzles (for gas flush) so that no gas is lost and the bag does not move during gas flushing

MACHINE CONTROL PANEL

CONTROL PANEL VERSIONS

- General** The digital control panels are implemented with 9 pre-select programs that can be individually set with different function values (to be able to pack different products) Program 0 can not be set and is used for servicing and testing. A program cycle is the complete program of set functions that the machine runs through to package a product. The control panels are designed with a operation mode and a program mode. The operation mode is used during operational activities for selecting the program number with the required program cycle. The set values of the function program can also be seen in the operation mode but not changed. The program mode is used to change the function values within the programs.
- The control panels are implemented standard with an automatic conditioning program for the regular maintenance of the pump and two STOP keys for complete cycle interruption or for only active function interruption. There are also a number of built-in service programs. Contact the supplier or PureVac for more information about these programs.
- Digital Time Control** The value of all active functions can be set for a certain time period. The vacuum function, gas flush function (if installed), and soft air function can be set in whole seconds up to a maximum of 99 seconds. The seal function can be set with an interval of 0.1 seconds and a maximum of 6.0 seconds.
- Digital Sensor Control** The value of the vacuum function and the gas flush function (if installed) can be set as a percentage of the vacuum. This is the percentage of the under pressure in the vacuum chamber related to the outside pressure 1 atmosphere/ATO (0%). The maximum vacuum percentage setting of the vacuum function is 99%. The minimum vacuum percentage setting of the gas flush function is 30%. This means that the chamber is flushed with gas to 30% under pressure in relation to 1 atmosphere. It is often expressed as 70% is flushed with gas ($99\% - 30\% = 70\%$). The time for the soft air function can be set on whole seconds (max. 99 seconds). The time for the seal function can be set on 0.1 seconds (max. 6.0 seconds).
- The digital sensor control comes standard with the VACUUM PLUS function. The VACUUM PLUS function is a time operated additional vacuum function for setting extra time after reaching the 99% value of the vacuum function (only applicable if 99% is set for the vacuum function). This function provides additional vacuum time for vacuuming any trapped air out of the package.

Contact the supplier or PureVac for information about special operating panels not shown above.

CONTROL PANEL LAYOUT

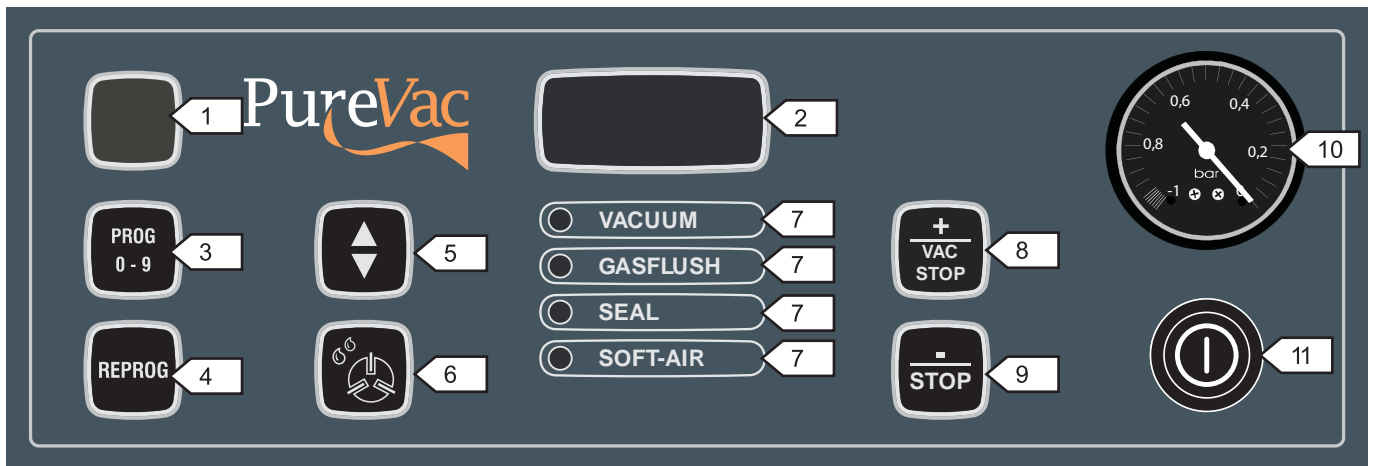

1. Small Display

Displays active program in operating and program modes.

2. Large Display

Displays the current value of the active function during the program cycle or the set value of the selected function in operation or program mode.

3. PROG 0-9 Keys

Selects program number in operation or program mode.

4. REPROG Key

Switch from operation mode to program mode (for setting function values) and vice versa. After setting new function value(s) within a selected program in program mode, this key must always be used to store the new values for the program in memory.

5. FUNCTION SELECT Key

Selects function within selected program in operation and program mode. The function is selected if the function light is on in front of the function description under the large display.

6. CONDITIONING PROGRAM Key

Start the conditioning program for pump (duration 15 minutes). For instructions on the program, see page 19.

7. FUNCTION Lights

A light in front of the function indicates that the function is active during the program cycle or that the function is selected during the operation or program modes.

Special Remark:

There is an additional time operated vacuum function available at digital sensor control, the VACUUM PLUS function. This function is not displayed on the panel. The VACUUM PLUS function can only be activated if the standard vacuum function is set to 99% VACUUM PLUS function display during the cycle (if activated) : The vacuum indicator light remains on after 99% is reached and during the time set for VACUUM PLUS. During the VACUUM PLUS vacuum cycle a dot appears in the right lower corner of the large display. Display during operation and program mode : If the VACUUM PLUS time is activated during the selected program then a dot appears in the lower right-hand corner of the large display during the operation and program mode. If the functions are selected using the function selection keys then the indicator light in front of VACUUM comes on twice, and the vacuum percentage and VACUUM PLUS time are shown consecutively.

Special Remark

If the machine has the gas flush function implemented and the function is activated within the selected program then a dot appears in the lower right hand corner of the small display when selecting the program no..

8. + / STOP VACUUM Key

Function during cycle

Interruption of the active function during the program cycle. The cycle immediately continues with the next function.

Function in program mode

Raise the value of the selected function within the program selected in the program mode.

CONTROL PANEL LAYOUT CONT.

9. - / STOP Key

Function during cycle Terminates the program cycle completely. The cycle immediately switches to the ventilation function.

Function in program mode Lower the value of the selected function within the program selected in the program mode.

10. Vacuum meter

Displays the pressure in the vacuum chamber. See the following table for the relationship between the vacuum meter and the percentage vacuum.

Position vacuum meter	Vacuum percentage
0	0
0.2	20
0.3	30
0.4	40
0.5	50
0.6	60
0.7	70
0.8	80
0.9	90
- 1.0	99+

11. ON/OFF Switch

The ON/OFF switch is used to turn the machine on and off before and after operation. The switch turns on all units in the machine. Caution, the switch does not completely remove all power from the machine.

OPERATION MODE

When the machine is turned on, the machine switches to operation mode after displaying the two codes (see page 4). The operation mode is the standard setting of the control panel for packaging products. Set values cannot be modified in operation mode.

With the PROG key and function selection keys the set values within the various programs can be viewed. If the machine is ready to package a product (the product is already in the chamber), then all that needs to be done is to choose the program (PROG key) and close the lid. The program cycle starts automatically running through the set functions in the program.

Description of the program cycle for digital time control

- Select the program number with the PROG key and the small display.
If the selected programme is programmed with the active gas flush function then a dot appears in the lower right hand corner of the small display.
- Close the lid.
- Vacuum function
The machine starts to vacuum the chamber.
The light in front of [VACUUM] goes on.
Large Display: decrementing time per second starting at the time set (max. 99 sec.).
Vacuum meter starts increasing to the left.
- Gas flush function
(if installed)
Once the vacuum function has completed then the gas flush function starts to flush gas into the vacuum chamber.
The light in front of [GAS] goes on.
Large Display: decrementing time per second starting at the time set (max. 99 sec.).
Vacuum meter starts decreasing to the right.

CONTROL PANEL LAYOUT CONT.

- 5. Seal function
 When the vacuum function or gas flush function (if installed) ends, the seal function starts to seal the vacuum bag(s).
 The light in front of [SEAL] goes on.
 Large Display: decrementing time per 0.1 second starting at the time set (max. 6.0 sec.).
 The reading on the vacuum meter stays the same.
- 6. Soft-air ventilation function (if installed)
 After ending the seal function the soft air function starts to slowly ventilate the vacuum chamber.
 The light in front of [SOFT AIR] goes on.
 Large Display: decrementing time per second starting at the time set (max. 99 sec.).
 Vacuum meter starts slowly decreasing to the right.
- 7. Ventilation function
 After ending the seal function or the soft air function (if installed) the ventilation function starts ventilating the chamber to 1 atmosphere/ATO and the lid opens.
 There are no longer any lights on in front of the functions.
 Large Display: lines going up and down until the lid is opened.
 The vacuum meter runs back to the right to zero and the lid opens automatically.
- 8. The product is packed and ready to remove.

Description of the program cycle for digital sensor control

- 1. Select the program number with the PROG key and the small display.
 If the selected program is programmed with the active gas flush function then a dot appears in the lower right hand corner of the small display.
 If the selected program is programmed with the active VACUUM PLUS function then a dot appears in the lower right hand corner of the large display.
- 2. Close the lid.
- 3. Vacuum function
 The machine starts to vacuum the chamber.
 The light in front of [VACUUM] goes on.
 Large Display: incrementing percentage vacuum until the percentage set (max.. 99%) and a dot in the lower right hand corner if the VACUUM PLUS function is activated.
 Vacuum meter starts increasing to the left.
- 4. VACUUM PLUS function (if installed)
 The machine continues vacuuming the chamber after 99% value is reached.
 The light in front of [VACUUM] goes on.
 Large Display: decrementing time per second starting at the time set (max. 99 sec.). and a dot in the lower right hand corner.
 The vacuum meter will very slowly increment to the left (hardly noticeable).
 Remark: can only be installed with a vacuum function whereby the value is set to the maximum of 99%.
- 5. Gas flush Function (if installed)
 Once the vacuum function has completed then the gas flush function starts to flush gas into the vacuum chamber.
 The light in front of [GAS] goes on.
 Large Display: decrementing percentage vacuum until the set percentage (min. 30%).
 Vacuum meter starts decreasing to the right.
- 6. Seal function
 When the vacuum function or gas flush function (if installed) ends, the seal function starts to seal the vacuum bag(s).
 The light in front of [SEAL] goes on.
 Large Display: decrementing time per second starting at the time set (max. 6.0 sec.).
 The reading on the vacuum meter stays the same.
- 7. Soft-air ventilation function (if installed)
 After ending the seal function the soft air function starts to slowly ventilate the vacuum chamber.
 The light in front of [SOFT AIR] goes on.
 Large Display: decrementing time per second starting at the time set (max. 99 sec.).
 Vacuum meter starts slowly decreasing to the right.

CONTROL PANEL LAYOUT CONT.

8. Ventilation function After ending the seal function or the soft air function (if installed) the ventilation function starts ventilating the chamber to 1 atmosphere/ATO and the lid opens.
 There are no longer any lights on in front of the functions.
 Large Display: lines going up and down until the lid is opened.
 The vacuum meter runs back to the right to zero and the lid opens automatically.
9. The product is packed and ready to remove.

PROGRAM MODE

The program mode is used to change the function values within the programs. See page 15-17 for instructions on programming.

OTHER MODES

The control panel also includes a service mode. The conditioning program (see page 19) for the pump and the operation hours counter are the functions most used in this mode.

Operation Hours Counter

One of the service functions is the operation hours counter in order to be able to automatically indicate regular service requirements. This functions sets the number of hours that the pump runs (per 10 hours). Note that for Premier series the pump does not run continuously. Once the number of hours set has been exceeded, the message [OIL] appears on the display (see page 8). The machine can still be used as usual but the message will keep reappearing on the display.

The factory setting for the program operation hours counter is OFF (turned off). The following steps can be followed to activate the operation hours counter or to reset it:



Press the FUNCTION SELECT Key for at least 3 seconds. After 3 seconds the number of operating hours (per 10 hours) will be displayed for about 2 seconds. After 2 seconds the originally set number of hours will be displayed (per 10 hours). When the operation hours counter is turned off, the number of operating hours will not be displayed, instead the message [OFF] will immediately appear after pressing the key for 3 seconds.

The original setting can be modified using the + and – keys (between 0 and 990 hours). If set to 0 then the next time [OFF] will automatically be displayed. The new settings are stored by using the REPROG Key. The actual operation hours are then also reset to zero.

After pressing the REPROG key, the control panel automatically switches over to operation mode.





PROGRAMMING

The function values in a selected program number can be changed using either manual or automatic programming. For units, range and limits of the function values refer to the previous chapter, MACHINE CONTROL PANEL.

10 programs can be selected and set, number 0 to 9. Note: program 0 cannot be programmed. The values in this program are set for service and reference use.

MANUAL PROGRAMMING

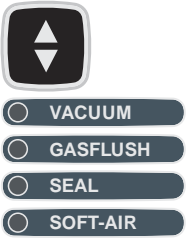





Starting situation: machine is in normal operation mode and the lid is open.

A.		Select the correct program with PROG 0-9 key for setting function values. Program number is displayed on the small display.
B.		Press REPROG key to switch into program mode. The program number now starts to blink on the small display.
C.		Select the required function for programming with the FUNCTION SELECT Key . The indicator lights will turn on for the active functions when selected. Remark on Seal function for option 1-2 cut-offseal At option 1-2 cut-offseal, the indicator SEAL lights up twice when selected. The first time is for setting the seal time and the second time for setting the cutting time. Remark on option Digital Sensor Control At option sensor control, the indicator VACUUM lights up twice when selected. The first time for the vacuum function (vacuum percentage) and the second time for the vacuum plus function (time duration), see pages 11,13
D.		Digital Time Control Set the amount of time required for the selected function by using the + and – keys. Digital Sensor Control Set the percentage of vacuum required or the amount of time required for the selected function by using the + and – keys. Remarks Set values are displayed on the large display. The functions vacuum plus (sensor control), gas flush and soft air can be turned off in the programme if required. For turning off a function press the – key until OFF appears on the large display.
E.		Repeat steps C and D for setting other function values.
F.		Press the REPROG key after setting all relevant functions to store the changes in the program. The control then automatically switches back to operation mode and the machine is ready for use. The newly set values are now the new default values

PROGRAMMING

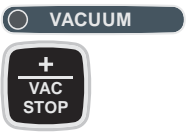
AUTOMATIC PROGRAMMING

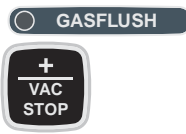
Starting situation: machine is in normal operation mode and the lid is open.

A.		Select the correct program with PROG 0-9 key for setting function values. Program number is displayed on the small display.
B.		Press REPROG key to switch into program mode. The program number now starts to blink on the small display.
Close the lid. The machine cycle starts automatically.		
C.		<p>VACUUM FUNCTION</p> <p><u>Digital Time Control</u> Time is increasing. As soon as the vacuum meter gets to -1 press the STOP VACUUM Key. The machine cycle automatically switches to the following function.</p> <p><u>Remark Digital Time Control</u> Let the vacuum function run 2 to 4 seconds longer after reaching -1 on the vacuum meter so that "trapped air" in the packaging is also extracted.</p> <p><u>Digital Sensor Control</u> The percentage vacuum increases. As soon as the value 99% is reached press the STOP VACUUM Key. The machine cycle automatically switches to the following function.</p> <p><u>Remark</u> If full vacuum is not required press the STOP VACUUM Key when the required value has been reached.</p>
D.		<p>VACUUM PLUS FUNCTION (only with digital sensor control)</p> <p><u>Digital Sensor Control</u> Time is increasing. Press the STOP VACUUM Key at the required time. The machine cycle automatically switches to the following function.</p> <p><u>Remarks</u> The VACUUM PLUS function can only be de-activated (OFF) by manual programming. The VACUUM PLUS function will only run when VACUUM function has been set at 99%.</p>
E.		<p>GAS FLUSH FUNCTION (optional)</p> <p><u>Digital Time Operation</u> Time is increasing. As soon as the vacuum meter gets to the required underpressure, press the STOP VACUUM Key. The machine cycle automatically switches to the following function.</p> <p><u>Digital Sensor Control</u> The percentage vacuum decreases. As soon as the required value is reached press the STOP VACUUM Key. The machine cycle automatically switches to the following function.</p> <p><u>Remarks</u> The minimal under-pressure advised is 0.5 bar or 50% vacuum. The minimum under pressure that can be set is 0.3 bar or 30%. GAS FLUSH function can only be de-activated (OFF) by manual programming.</p>
F.		<p>SEAL FUNCTION</p> <p>Can only be programmed manually. For automatic programming, the set time length will be run and the machine cycle will automatically carry on with the next function.</p>
G.		<p>SOFT AIR FUNCTION / STORE FUNCTION VALUES IN PROGRAM</p> <p><u>Digital Time and Sensor Control</u> Time is increasing. As soon as the desired setting is reached press the STOP VACUUM Key. After this operation the machine cycle ventilation starts and the lid opens. The values are automatically stored and control panel reverts automatically to the operation mode. The machine is ready for use.</p> <p><u>Remarks</u> The soft air function can only be de-activated (OFF) with manual programming.</p>

SPECIAL REMARKS ON PROGRAMMING

For Digital Sensor Control

The value which is set for the gas flush function is the final vacuum percentage in the vacuum chamber after flushing gas. For example, the vacuum function is set to 99% and gas flush function is set to 60%. This means that after the vacuum function the chamber will be flushed with gas until there is 60% vacuum and 40% (actually 39%) gas in de vacuum chamber.

For automatic programming.

Ensure that all functions are activated in the selected program. Activation means that the function in the program is assigned a value. If the value is OFF then that means that the function is not activated and will not be included in the automatic programming cycle.

For machines with optional gas flush function.

If a program is setup with the active gas flush function then this is indicated by a dot in the lower right hand corner of the small display when selecting the program in the operation mode.

For machines with optional sensor control.

If a program is setup with the active VACUUM PLUS function then this is indicated by a dot in the lower right hand corner of the large display when selecting the program in the operation mode.

If the function's value is OFF then it can only be activated using manual programming.

Contact the supplier or PureVac for more information about programming.

MACHINE MAINTENANCE

GENERAL

Regular, thorough maintenance is essential for extending the machine's life, for preventing malfunctions and for achieving an optimal packaging result. If the machine is used intensively (more than 5 hours per day) then it is a professional service is recommended every 6 months. In other cases one complete service per year is sufficient (depending on location, environment and products).

There are however also small maintenance activities that must be carried out more regularly and that the user can do himself. The following page contains an overview of these activities.



IMPORTANT BEFORE AND DURING MAINTENANCE

- The machine must always be completely voltage free before any maintenance is carried out on it. Remove the plug from the wall socket or put the master switch in the O position.
- If the machine is not functioning properly or if it produces strange noises, turn it off immediately with the ON/OFF switch and contact the supplier or PureVac.
- If the machine is equipped with a gas flush system then always close the main cock during standard maintenance activities. Always take care that the pressure on the pressure reducing valve on the gas bottle is never higher than 1 atmosphere/ ATO before, during and after the maintenance activities. A higher pressure may cause irreparable damage to the machine. NEVER use flammable gasses or gas mixtures containing oxygen.
- When cleaning transparent lids (if applicable), NEVER use cleaning agents containing solvents. Check at least once a week if there are cracks in the lid. In case of cracks, turn off the machine immediately and contact the supplier or PureVac.
- High pressure cleaning is not permitted for cleaning the machine. High pressure cleaning can cause considerable damage to electronic and other parts of the machine.
- Water may never be permitted to enter either the extraction nozzle of the chamber or the blow-off opening of the pump. This would cause irreparable damage to the pump.
- Larger services must always be carried out by an authorised supplier.
- The Premier machines are designed for a maximum of 5 hours operation per day. Other machines are designed for a maximum of 8 hours per day. The supplier or PureVac cannot be held responsible for any malfunctions or defects if these operation time limits are clearly exceeded without consultation.
- The machine must be moved or transported in an upright position. The machine may NOT be tilted as it can cause damage to the pump.
- The supplier or PureVac cannot be held responsible for any malfunctions or defects if the maintenance instructions in this manual are not followed.
- Contact the supplier or PureVac if there are any doubts or questions about maintenance or malfunctions.

MACHINE MAINTENANCE

STANDARD MAINTENANCE SCHEDULE FOR THE MACHINE

Daily	<ul style="list-style-type: none"> • Clean the vacuum chamber, lid, and housing after use with a damp cloth. • Make sure that no cleaning agents containing solvents are used. • Make sure that no high pressure cleaner is used.
Weekly	<ul style="list-style-type: none"> • Check the oil level and replace or fill up oil when the oil is turbid or the oil level is too low. For instructions, see page 20. • Activate the conditioning program for the pump at least once a week. • Inspect the sealing bar for damage. Replace teflon tape/sealing wire if the seal quality is no longer sufficient or if the teflon tape/sealing wire is no longer tight and straight on the sealing bar. For instructions, see page 23. • Inspect the lid gasket and replace it when the gasket is damaged or stretched. For instructions, see page 24. • Inspect the transparent lid (if applicable). When cracks are visible, turn off the machine immediately and contact the supplier or PureVac.
Every Six Months	<ul style="list-style-type: none"> • Replace oil at least once every 6 months.
Yearly	<ul style="list-style-type: none"> • Inspect the oil exhaust filter for saturation. If saturated, replace the filter. For instructions, see page 21. • Contact the supplier for a professional service
Four-yearly	<ul style="list-style-type: none"> • Replace transparent lid and the lid's gas springs (if applicable) • Replace membranes seal cylinder (if applicable)

VACUUM PUMP MAINTENANCE

It is very important to regularly service the pump to ensure extended and correct operation. The following activities are essential for correct maintenance. If the machine is used regularly then it is advisable to have the pump fully inspected at least once a year by the supplier to ensure extended and problem free operation. Contact the supplier or PureVac for more advice and information.



Conditioning Program

The conditioning program ensures that the pump is thoroughly rinsed. During the program the pump and oil reaches operation temperature so that the oil can better absorb any moisture and contaminants and filter them. The high temperature enables any moisture in the pump to evaporate minimising the risk for rust spots.

The program lasts 15 minutes and it is advisable to run it at least once a week. Turn on the machine, press the key [conditioning program], and close the lid. The program runs automatically. During the program the large display will display moving lines.

The program can be interrupted at any time using the [STOP] key. It is however important for the sake of good maintenance that the program completes a full 15 minute cycle and therefore advisable only to interrupt the cycle for something urgent.

It is also advisable to run the program before using the machine for the first time, after the machine has been stationary for a lengthy period of time, and especially prior to changing oil.

MACHINE MAINTENANCE

Changing Oil / Filling Up

The oil level and oil quality must be checked at least once a week. The oil inspection window serves this purpose. Fill up the oil level if it is too low. Replace the oil if it is turbid. Oil must be replaced at least once every 6 months.

PREMIER SERIES

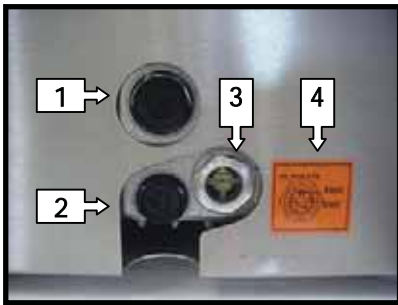

1. Oil fill plug
2. Oil drain plug
3. Oil inspection window
4. Oil level indicator sticker

Take care to use the correct type of oil for the pump

Beware of hot oil fumes during drainage

ULTRA SERIES

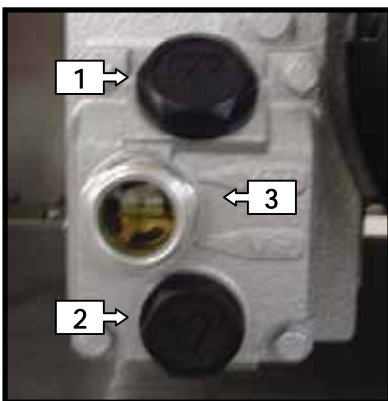

Draining oil

If the oil is white or turbid when checked then it must be replaced. Before draining off the oil let the conditioning program run a full cycle. The dirt and moisture is absorbed by the oil and the oil becomes thinner making draining easier.

After the program has ended the drainage plug can be removed.

CAUTION, when unscrewing hot oil fumes can escape. The oil now drains from the drain hole (an oil pan must be placed underneath). For the Premier series, when the oil has drained, tilt the machine slightly so that all residual oil can drain off. After draining the oil drain plug is replaced.

Filling up oil

After draining or if the oil level has dropped, oil needs to be filled up. The oil fill plug must be removed with the correct size spanner. The pump can now be filled with oil. Make sure that you add the correct amount (see table on page 24)

TAKE CARE to fill with small amounts at intervals. Fill the oil level to the top of the oil level indicator sticker.

TAKE CARE to replace the oil filter before adding the new oil (see page 24)

Oil types and amounts

It is important to use the correct type and quantity of oil for the pump. The wrong type or too much oil could damage the pump. The ambient temperature where the machine is operated is also important for the type of oil. See amounts and types with related ambient temperatures in the table on the next page.

Examples of supplier brands for the standard types of oil are Shell Vitrea, Aral Motanol GM, BP Energol CS, or Texaco Regal R+ O with related viscosity numbering. If the machine is used outside normal specifications regarding ambient temperature, contact the supplier or PureVac.

MACHINE MAINTENANCE

Machine Type	Pump Capacity	Filling (litres)	Standard Oil type 10 - 30 °C	“Cold” Oil type 5 - 10 °C	“Hot” Oil type 30 - 40 °C
Premier 1635	016 m ³ /h	0.4	Viscosity VG 32	VM 32	VS 32
Premier 2142 / 2141-2	021 m ³ /h	0.4	Viscosity VG 32	VM 32	VS 32
Ultra 6352-2	063 m ³ /h	1.0	Viscosity VG 100	VM 100	VS 100

Machines are supplied with standard type oil.

The capacity of models with a 063 m³/h pump and 60Hz voltage, is 2.0 litre instead of 1.0 litre.

Changing the oil filter

The pumps of all models except the Premier series have oil filters. When replacing the oil the filters must also be replaced. The oil filter is screwed to the rear of the oil exhaust filter housing.

When replacing the oil, it is first drained off. The old filter is then screwed off and replaced by a new one. The pump can now be filled with new oil.

For the correct type of oil filters refer to the list of maintenance parts on page 29.



Inspect and change oil exhaust filter

There are one or more oil exhaust filters in the pump which absorb and filter oil vapours. The filters will become saturated after a period of time and need to be replaced. This is on average between 12 and 18 months. When the filters are saturated it is no longer possible to achieve maximum vacuum.

Filter housing types



016-021 m³/h

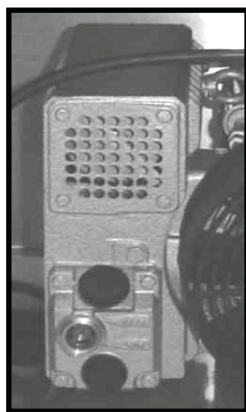

040-063-100 m³/h



160-300 m³/h

- Filter housings can be located at the side or behind the machine
- Appearance can vary depending on the model (multiple housings on pump or multiple filters in one housing)

Change oil exhaust filter(s)



Open rear or side of machine for pump



Screw the cover(s) from the filter housing)



The filter(s) is/are visible behind a tensioner



Release the tensioner(s) with a spanner



Remove tensioner(s) and filter(s) from the housing



Take care that the filter gasket does not remain behind when removing the filter

- Place and tension the new filter (take care that the gasket is correctly positioned) in the housing
- Screw the cover back onto the housing
- Screw the back or side plate on the machine

- Pumps and housing can have a different appearance but the principle of replacing remains the same.
- Take care that the correct type of filter is used for the pump type, see page 25 for the correct type of filter for the type of pump
- It is advisable to have the supplier do this service.

SEALING SYSTEM MAINTENANCE

All or some of the following sealing systems are possible in the Premier/Ultra series. It is essential to know which sealing system is applicable to the relevant machine.



DOUBLE SEAL
2 x 3,5 mm seal

Servicing the sealing bar is almost identical for all systems. The seal quality is partially dependent on the maintenance of the sealing bar and contra-bar (silicone holder). The main maintenance activities are the daily cleaning of the sealing bar and the silicone holder with a damp cloth and a weekly inspection of the bars with replacement of the sealing wire, teflon tape or silicone rubber if irregularities appear on top of the bar or the seal quality is insufficient.

The average maintenance cycle of the sealing bar (teflon tape / sealing wire) is at least once every 3 months. (This indication refers to regular use of the machine, on average 8 hours per day and packaging standard products with standard vacuum packaging materials. No rights can be derived from this indication)

Replace sealing wire and teflon tape

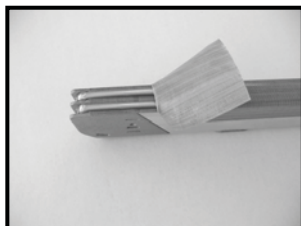

Remove teflon tape

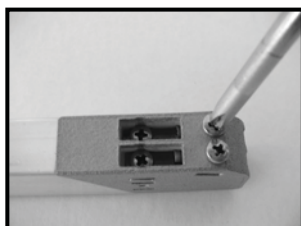

Unscrew and remove sealing wires



Replace the teflon tape

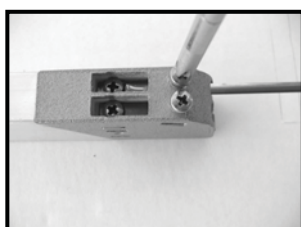

Screw down new wires onto clamping plate



Pull wires taut using a pair of pliers and a vice and screw the wires down on the clamping plate.



1. Remove the sealing bar(s) from the holders (in the chamber or lid) by releasing the click system or by unscrewing the screws.
2. Remove the teflon tape from the sealing bar.
3. The old sealing wires and cut-off wires (if applicable) can be removed by unscrewing the clamp (see illustration) and pulling the wires from the grooves.
4. Remove the teflon tape that is attached to the top of the sealing bar and stick a new piece of teflon tape to the bar of the same length after having degreased and cleaned the bar with a dust free cloth.
5. Cut a new piece of sealing wire or cut-off wire to the size of the sealing beam plus about 15 cm (± 6 inches). If 2 sealing wires or an extra cut-off wire is on the sealing beam then a second sealing wire or cut-off wire must of course be cut.
6. Place the end of the wire or wires through the groove(s) on the side of the sealing beam and screw the wires to the bottom.
7. Place the sealing bar top down in a vice and pull the sealing wire or wires through the other side of the groove(s) on the sealing beam.
8. Pull the wires tight with a pair of pliers and screw them down at the same time. Ensure that the wire (wires) is (are) pulled taut and straight with the help of a pair of pliers before the wires are screwed down.
9. It is handy to use a pair of adjustable pliers as a lever for optimal wire tension. Place one end of the sealing beam in the vice and stretch the wire (wires) by pressing down the bar.
10. Cut off the extruding wire end(s) on both ends after having screwed it tight.
11. Cut a piece of teflon tape as long as the sealing bar plus about 5 cm (± 2 inches).
12. Stick the new teflon tape straight over the new sealing wire (wires). Ensure that the teflon is straight on the sealing bar and that the sticky part is stuck on the side. Ensure that the teflon is stuck on the bar smoothly and without folds.
13. Cut the teflon tape off so that the sticky part does not get stuck on the sides of the clamps but that the teflon extends over the top of the clamps.
14. Place the sealing bar back in the machine. Ensure that the sealing beam is properly clicked onto the holders or that the screws are firmly screwed in.

Special remark bi-active sealing system The sealing wire must be accurately placed on the upper and lower beams so that the sealing wires line up with each other exactly during sealing

**See page 25
for correct parts and quantities**

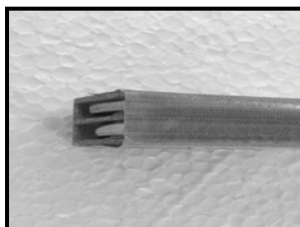

Cut off the ends of the sealing wire and stick Teflon tape over the sealing beam without folds

SILICONE HOLDER AND LID GASKET MAINTENANCE

Replace the rubber silicone holder

The silicone holder must be inspected weekly for irregularities on the silicone rubber (mainly caused by burning by the sealing wire). If irregularities appear then the silicone rubber must be replaced.

Average maintenance cycle for silicone rubber is at least once every 6 months (This indication refers to regular use of the machine with standard products. No rights can be derived from this indication)

1. Remove the old silicone rubber from the holder.
2. Cut a new piece of silicone rubber the same size as the old one.
The same size is very important, too short or too long will cause problems with sealing.
3. Place the new piece in the silicone holder. Ensure that the silicone rubber is completely and evenly placed in the groove. It is also important that the surface of the silicone rubber is smooth after it is in place and it shows no signs of tension.

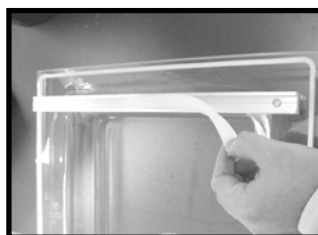

Replace lid gasket

The lid gasket ensures that the vacuum chamber is completely sealed during the machine cycle. This is essential for achieving a maximum vacuum. The lid gasket wears due to the extreme pressure differences and must be replaced regularly. Inspect the lid gasket weekly for tears or damage.

Average maintenance cycle for lid gasket is at least once every 6 months (This indication refers to regular use of the machine, on average 8 hours a day and with standard products. No rights can be derived from this indication)

The length of the new lid gasket is determined by using the old gasket. If the lid rubber is too short or too long it can cause problems closing the lid or leak.

The rubber must be placed evenly and without tension in the holder. The ends must be cut straight and must be laid tightly against each other to avoid leakage.

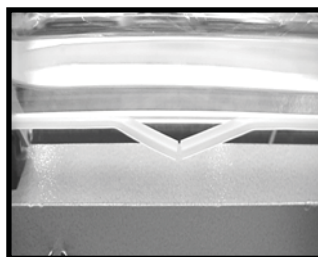

Ensure that the ends of the lid rubber connect up closely

LIST OF SERVICE PARTS

VACUUM PUMP PARTS

BUSCH VACUUM PUMPS	PureVac MODELS
016m ³ /h	Premier 1635
021m ³ /h	Premier 2142 / 2141-2
063m ³ /h – 50Hz	Ultra 6352-2

BUSCH	STANDARD OIL			OIL FILTER		OIL MIST FILTER		
	Type	PureVac Reference	Litres	Type	PureVac Reference	Type	PureVac Reference	Amount
016m ³ /h	VG 22	0439510	0.40	-	-	50-60Hz	0939003	1
021m ³ /h	VG 32	0439510	0.40	-	-	50-60Hz	0939005	1
063m ³ /h – 50Hz	VG 100	0439520	1.0	040-063-100	0939090	50Hz	0939011	1

SEAL SYSTEMS

PARTS	SPECIFICATIONS	PureVac Reference	QUANTITY
Teflon Tape	46 mm teflon tape	0305515	length sealing bar + 5 cm
Double Seal	2 x 3.5 mm round wire	0305000	2 wires length of sealing beam + 15 cm

LID GASKET

MODELS	PureVac REFERENCE	LENGTHS PER MODEL (in cm)
Premier SERIES	0320215	Premier 1635
		Premier 2142
		Premier 2141-2
Ultra SERIES	0320210	Ultra 6352-2

Lengths specified are always a little longer and must be cut to the correct length.

TECHNICAL SPECIFICATIONS

MODEL	VACUUM CHAMBER	LID	HOUSING	DIMENSIONS (mm)	PUMP (m3/h)	FINAL VACUUM (%)
Premier SERIES 1635 2142 2141-2	Stainless-steel	Transparent	Stainless-steel	450x525x385	016	99.80%
490x525x430				021		
490x610x445				021		
Ultra SERIES 6352-2	Stainless-steel	Transparent	Stainless-steel	700x690x1030	063	99.98%

Specifications may deviate with optional models

Standard ambient temperature	5°C – 30°C
For deviating ambient temperatures	see page 24 for special oil specifications
Maximum use per day	Premier series 5 hours per day Other machines: 8 hours per day
Electricity	Voltage: see machine tag
	Frequency: see machine tag
	Power: see machine tag
Electrical connection	Maximum fluctuation $\pm 10\%$ of the official registered voltage
Gas bottle connector diameter (if applicable)	Premier series diameter 6 mm OTHER MODELS diameter 8 mm
Maximum pressure gas bottle connector (if applicable)	1 ATO
External seal pressure connection (if applicable)	diameter 6 mm
Sound level	< 70 DB

ELECTRICAL DIAGRAMS

CONTROL CURRENT DIAGRAM PREMIER SERIES

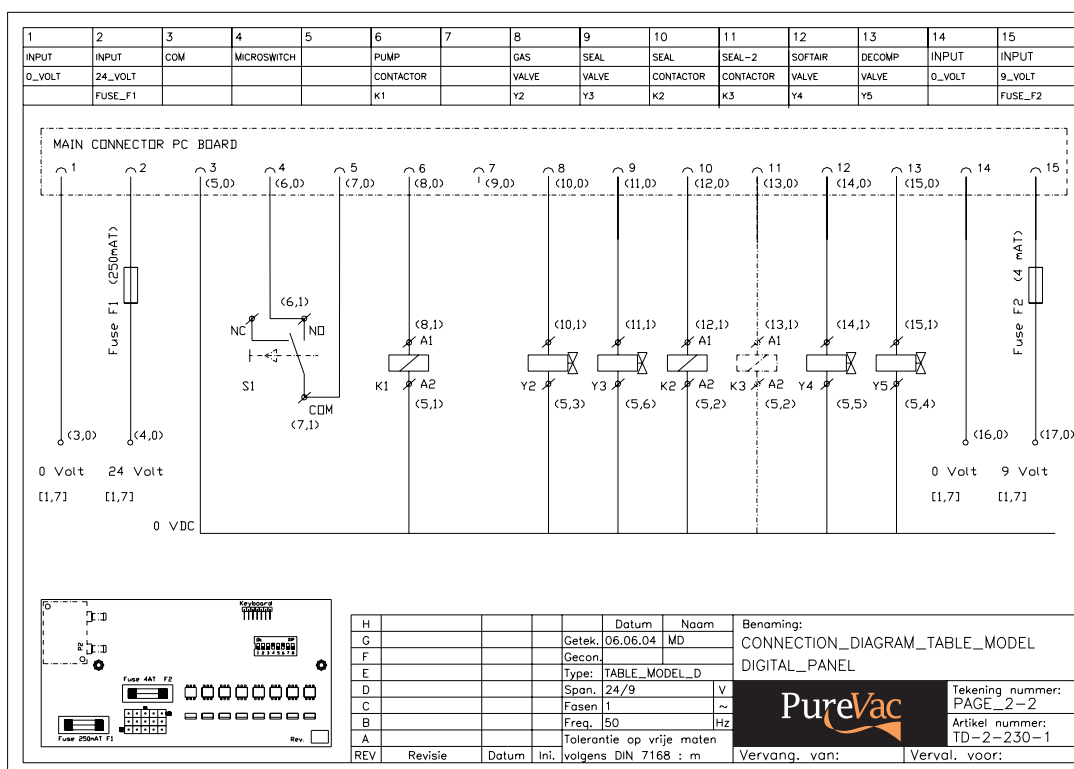

ELECTRICAL DIAGRAMS

POWER CIRCUIT DIAGRAM PREMIER SERIES

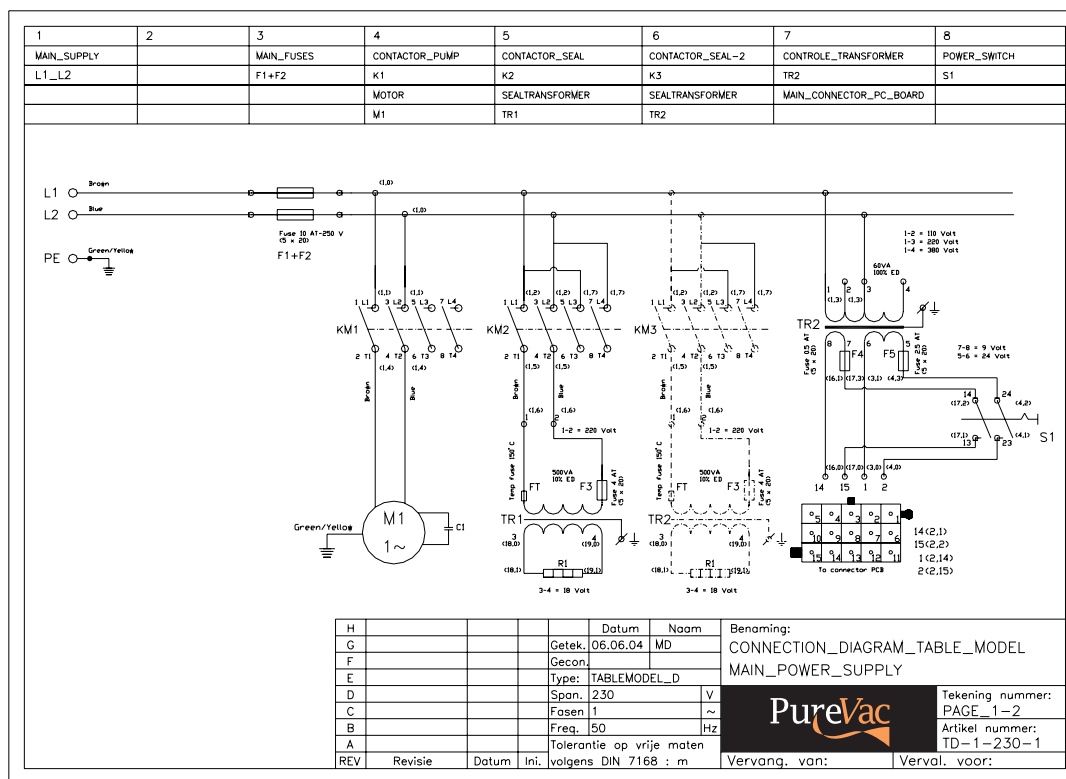

Diagrams are shown for standard configurations.

CONTROL CURRENT DIAGRAM ULTRA SERIES

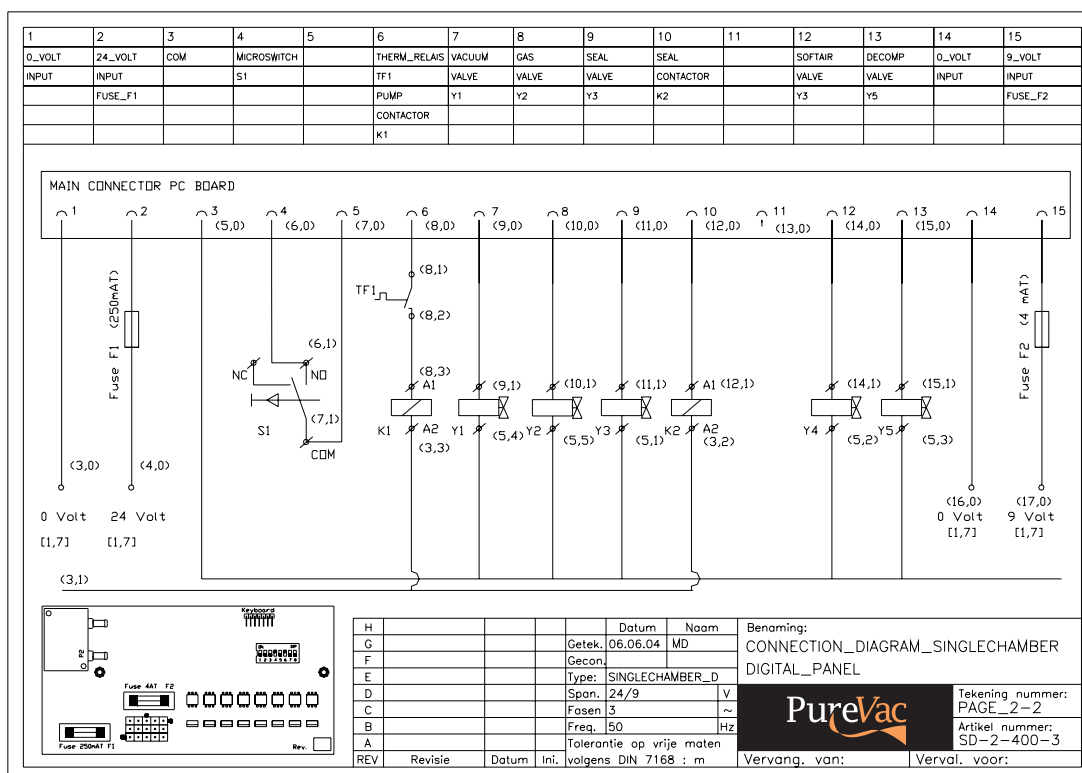

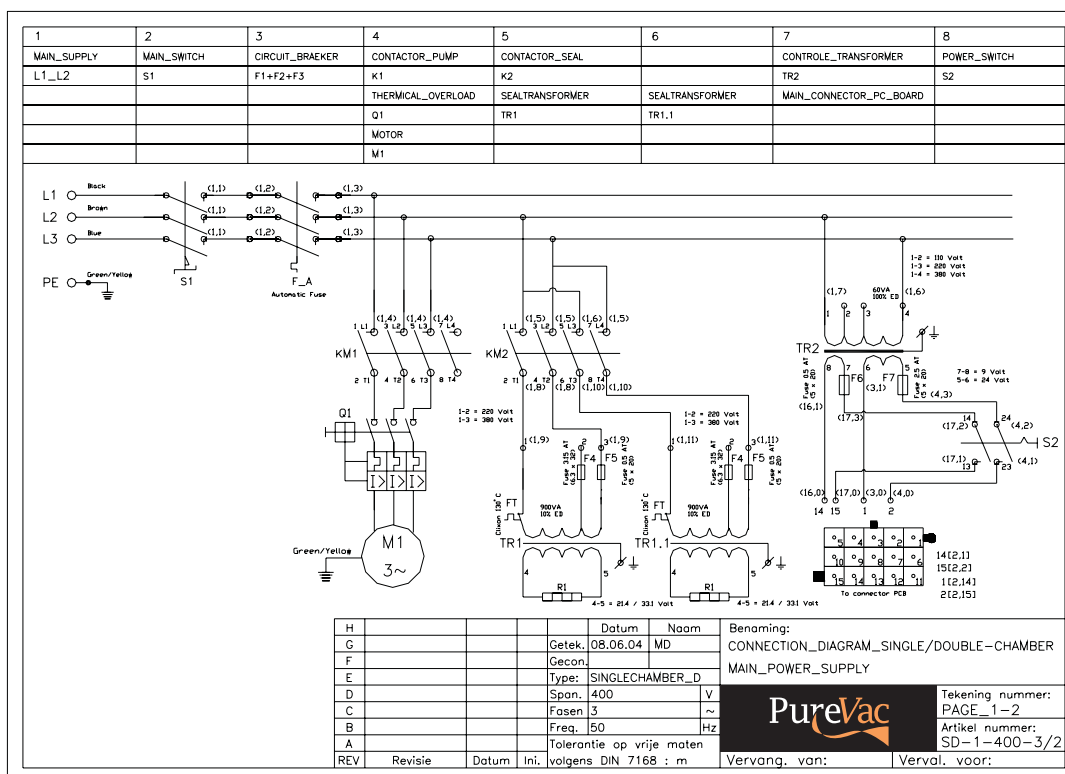
POWER CIRCUIT DIAGRAM ULTRA SERIES

Diagrams are shown for standard configurations.

LIST OF FUSES

- Fuses are located where the power enters the component board
- Fuses are been located on transformers (control and seal)
- Two fuses are placed on the control circuit.

Due to different mains voltages and machine models there is a variety of fuse types that can be present in the machine. Refer to the specifications of the relevant component for the correct types and values of fuses for replacement, or contact the supplier or PureVac.



Caution, to avoid fire and/or other irreparable damage to the machine, replacement fuses must always be of the same type with the same value as the fuses being replaced!!

VOLTAGE



Caution, the maximum allowable voltage fluctuation is $\pm 10\%$ of the official voltage stated on the machine tag.

ERROR CODES

The controls are programmed with a number of error codes. These error codes are intended to give the user / dealer a clear indication of what the possible cause might be why starting or packaging is not working as expected.

F1: This code indicates that the cycle (cover switch) will be interrupted prematurely.

Example: the cover of the machine closes after starting, but before sufficient vacuum is present to keep the cover closed the operator lets go of the cover. The F1 code will now be shown on the display. In a time-controlled machine, the time for gassing is set in such a way that the entire chamber is gassed and the cover opened without sealing taking place. Here too the F1 code will immediately be shown on the display. This message will never be shown directly after the controls are started, but during the course of the cycle.

F2: This code indicates that the sensor is not working properly.

When the controls are started, the condition of the sensor is checked. If the feedback data of the sensor are not correct, F2 is shown on the display. This message will be shown directly after the sensor controls are started.

RP-: This message will be shown when, due to circumstances, the controls are unable to retrieve the programme values. The word 'circumstances' means peak tensions or a tension drop during starting. When such a situation occurs, the print will start with this message and go no further. Two options exist now: the machine can be switched off and on again to see if the problem repeats itself or the reprog key can be pressed. By operating the reprog key, the controls will use the factory settings to start. The programme values set by the client will be cancelled as a result. This message will be shown directly after the controls are started.

If one or more of the above messages continue to occur regularly or cause a direct problem, we advise you to contact your dealer.

PNEUMATIC DIAGRAM

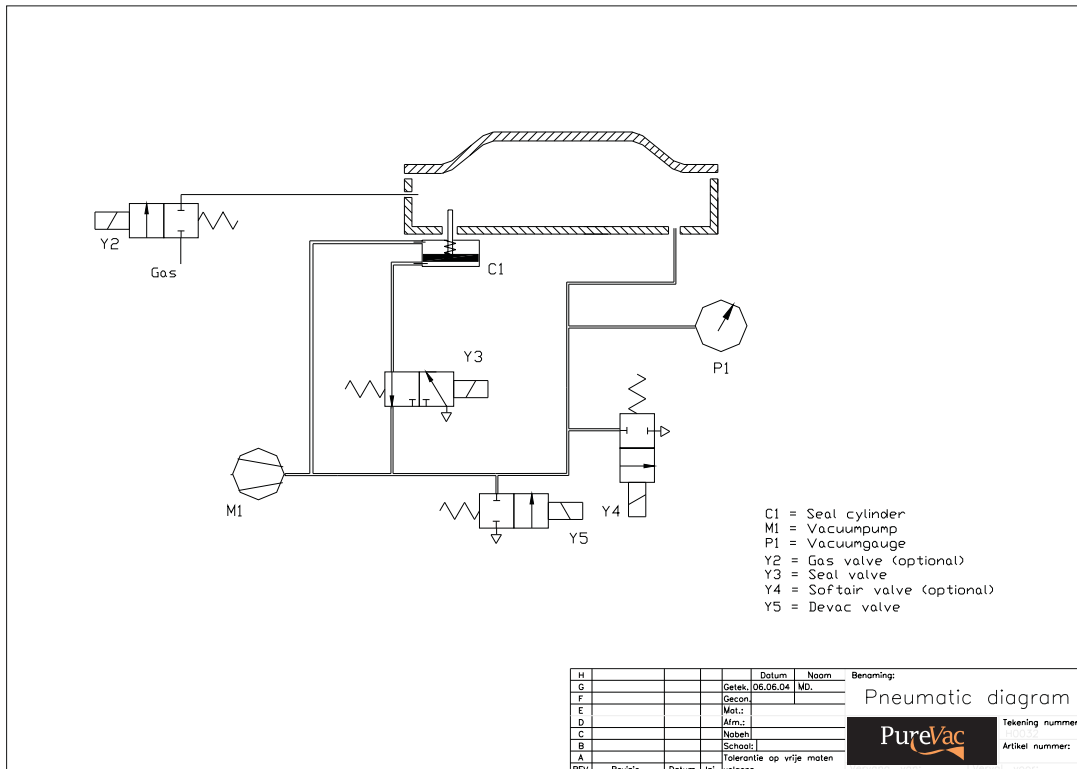

PROBLEM SOLVING

PROBLEM	CAUSE	SOLUTION
Machine does not work	<ul style="list-style-type: none"> The plug is not plugged into the wall socket. The main fuse is burnt. The ON/OFF switch's contact block has come loose. The circuit board fuse is burnt. 	<ul style="list-style-type: none"> Plug the plug into the wall socket. Replace the fuse (Ensure the correct value). Check this and if necessary re-fasten it. Disassemble the front panel and replace the fuse.
Machine does not work Operating panel is on	<ul style="list-style-type: none"> The control transformer fuse is burnt. The micro-switch that is activated when the lid is closed is disordered or faulty. There is an internal malfunction. 	<ul style="list-style-type: none"> Check this and if necessary replace it. The micro-switch must be properly adjusted or replaced Consult the supplier.
Transparent lid does not open automatically	<ul style="list-style-type: none"> The gas spring is faulty 	<ul style="list-style-type: none"> Consult the supplier.
Final vacuum is insufficient	<ul style="list-style-type: none"> The set vacuum time is too short. There is too little oil in the vacuum pump. The extraction hole at the back of the vacuum chamber is partially covered by the vacuum bag during extraction The lid gasket is worn. The oil is contaminated The oil exhaust filter is saturated. 	<ul style="list-style-type: none"> Extend the vacuum time. Check the oil level and top up if necessary (Note the type and quantity). Place the vacuum bag closer to the sealing beam. Replace the lid gasket. Replace the oil (Note the type & amount). Replace the oil exhaust filter / Consult the supplier.
The machine builds up a vacuum slowly	<ul style="list-style-type: none"> The pump's extraction filter is blocked. The oil exhaust filter is saturated. 	<ul style="list-style-type: none"> Consult the supplier. Replace the oil exhaust filter / Consult the supplier.
The vacuum bag is not properly and/or correctly sealed.	<ul style="list-style-type: none"> The vacuum bag is being placed incorrect on the sealing bar. The sealing time is too long or too short. The silicone rubber in the silicone holder is damaged or worn. The teflon tape is damaged. The inside of the vacuum bag opening is contaminated or greased. 	<ul style="list-style-type: none"> Place the vacuum bag neatly and smoothly on the sealing bar. Ensure that the opening of the bag is always within the vacuum chamber. Adjust the sealing time longer or shorter. Replace the silicone rubber. Replace the Teflon tape Clean the vacuum bag's opening.
The amount of gas in the vacuum bag is insufficient (optional).	<ul style="list-style-type: none"> The gas bottle is empty or nearly empty. The gas bottle is still closed. Gas flush time is too long or too short. The gas flush pressure is incorrectly set. 	<ul style="list-style-type: none"> Replace the gas bottle. Check if the valve on the gas bottle is closed. If so, open it. Shorten or extend the gas flush time. Check if the manometer or the secondary pressure of the gas is set to 1 atmosphere (1-ATO). <p>WARNING! The pressure of the gas mixture may never be more than 1 atmosphere/ATO.</p>

In the case of other problems or questions contact the supplier or PureVac.

DIGITAL TIME CONTROL FACTORY SETTINGS

Program	0**	1	2	3	4	5	6	7	8	9
Vacuum time	30	25	20	15	10	30	25	20	20	15
Gas flush time*	OFF	OFF	OFF	OFF	OFF	5	5	10	15	15
Sealing time	2.5	2.5	2.5	2.5	2.5	2.5	2.5	2.5	2.5	2.5
Soft-air time*	3	3	2	2	2	OFF	OFF	2	OFF	OFF

* Only applicable if the machine is equipped with the options in question.
 If the machine is not equipped with the gas flush system and/or soft air ventilation then these options will not be available on the control panel.
 ** Program 0 cannot be modified

DIGITAL SENSOR CONTROL FACTORY SETTINGS

Program	0**	1	2	3	4	5	6	7	8	9
Final vacuum pressure %	99	90	99	99	99	80	90	50	90	60
Vacuum plus time	15	OFF	15	10	10	OFF	OFF	OFF	OFF	OFF
Final vacuum pressure % after gas flush*	OFF	OFF	80	70	60	50	80	OFF	80	30
Sealing time	2.5	2.5	2.5	2.5	2.5	2.5	2.5	2.5	2.5	2.5
Soft-air time*	3	3	2	2	2	OFF	OFF	2	OFF	OFF

* Only applicable if the machine is equipped with the options in question.
 If the machine is not equipped with the gassing system and/or soft air ventilating then these options will not be available on the operating panel.
 ** Program 0 cannot be modified

CUSTOMER SETTINGS TO BE FILLED IN

Program	0	1	2	3	4	5	6	7	8	9
Vacuum time Final vacuum pressure %	99									
Vacuum plus time	15									
Gas flush time* Final vacuum pressure % after gassing*	OFF									
Sealing time*	2.5									
Soft-air time*	3									

REMARKS ON SPECIAL APPLICATIONS

MACHINE WITH GAS FLUSH SYSTEM (if applicable)

If the machine is equipped with the gassing system then the following remarks are important :

NEVER USE GAS MIXTURES WITH MORE THAN 20% OXYGEN AND OR OTHER EXPLOSIVE GASSES. THIS COULD CAUSE FATAL EXPLOSIONS.

NEVER USE SEPARATE GAS BOTTLES WITH A MIXER WHEREBY ONE OF THE BOTTLES IS ONLY FILLED WITH OXYGEN. MALFUNCTIONING OF THE MIXER OR IF THE OTHER BOTTLE WERE TO BE EMPTY COULD CAUSE FATAL EXPLOSIONS.

All guarantees and/or liability expire in the case of accidents and/or damage caused by using oxygen or other explosive gasses.

The maximum gas pressure that can be set in the packaging is 35% (-0.35 bar on the vacuum meter). This means that there is 65% gas and 35% vacuum (under pressure) in the packaging. If a higher gas pressure results in insufficient seal quality contact the supplier or PureVac for more information about connecting external seal pressure.

PureVac recommends checking the pressure and amount of gas in the gas bottles regularly. Ensure that the gas bottle(s) is(are) correctly anchored. Always turn off the main cock on the gas bottle if the machine is not in operation or if the gas flush function is not active.

PACKAGING LIQUID PRODUCTS

The machines can be also used for packaging liquid products like soups or sauces. In this process the vacuum process must be carefully monitored (only possible with transparent lid or lid with inspection window). The [STOP VACUUM] key must be pressed as soon as bubbles appear in the product; the saturation point (same as boiling point) has then been reached.

Settings for programs for packaging liquid products can best be programmed using automatic programming (see page 16-17).

The saturation point of liquids is reached at a certain ratio line of low pressures and high temperatures (see the example table for water below). The saturation point will be reached sooner in the vacuum process when packaging liquids with a high temperature (the amount of vacuum will therefore be less).

PureVac recommends therefore to first cool liquid products before packaging. By so doing an optimal vacuum can be achieved for the product.

Saturation point of water – relation between the pressure and temperature of the water

Vacuum pressure [mbar]	1000	800	600	400	200	100	50	20	10	5	2
Boiling Point Temperature [°C]	100	94	86	76	60	45	33	18	7	-2	-13

A handy tip when packaging liquid products is to use a liquid insert plate so that the product remains at the bottom of the packaging during the vacuuming process and there is less risk of liquid splashing out of the packaging. Contact the supplier or PureVac for more information about the liquid insert plate

EXTERNAL VACUUMING OF FOOD CONTAINERS (if applicable)

The Premier and Ultra series can be equipped with an option for externally vacuuming special food containers. This system can vacuum special containers for longer storage life of the (food) products in the dish. The container has a special lid with valve. Contact the supplier or PureVac for more information about the containers. The system for the machine consists of a hose with vacuum applicator.

Operation External Vacuuming Food Containers

1. Start the machine
2. Place the hose connector over the extraction opening of the vacuum chamber of the machine

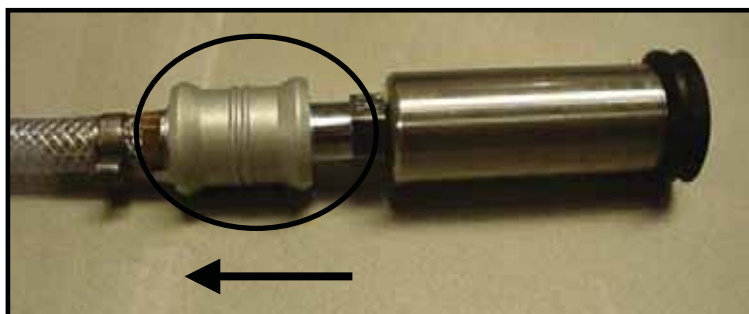

3. Check that the sliding valve on the vacuum applicator is on the side of the hose (closed position).
4. Press the PROG 0-9 Key until [E] (External Vacuuming) appears on the small display.



5. Place the vacuum applicator over the valve of the container and slide the sliding valve towards the lid to open the valve.



6. Press the + Key. The vacuum pump starts to run and the container is vacuumed.

7. When the vacuum meter reaches -1 then the container is fully vacuumed.

8. Press the - Key to stop the vacuum pump

9. The vacuum applicator can now be removed from the lid by sliding back the sliding valve.



10. The container is now ready for storage and/or stock.

11. If the machine needs to be used for normal applications then the hose can be removed from the extraction opening and the required program chosen using the PROG 0-9 Key.

REMOVAL TOOLS FRONT PANEL

With every machine we ship-out we enclose two special tools to make it possible to remove the front panel. The tools slide in the slots at the bottom side of the front panel. Now lift it a little and pull it towards you.

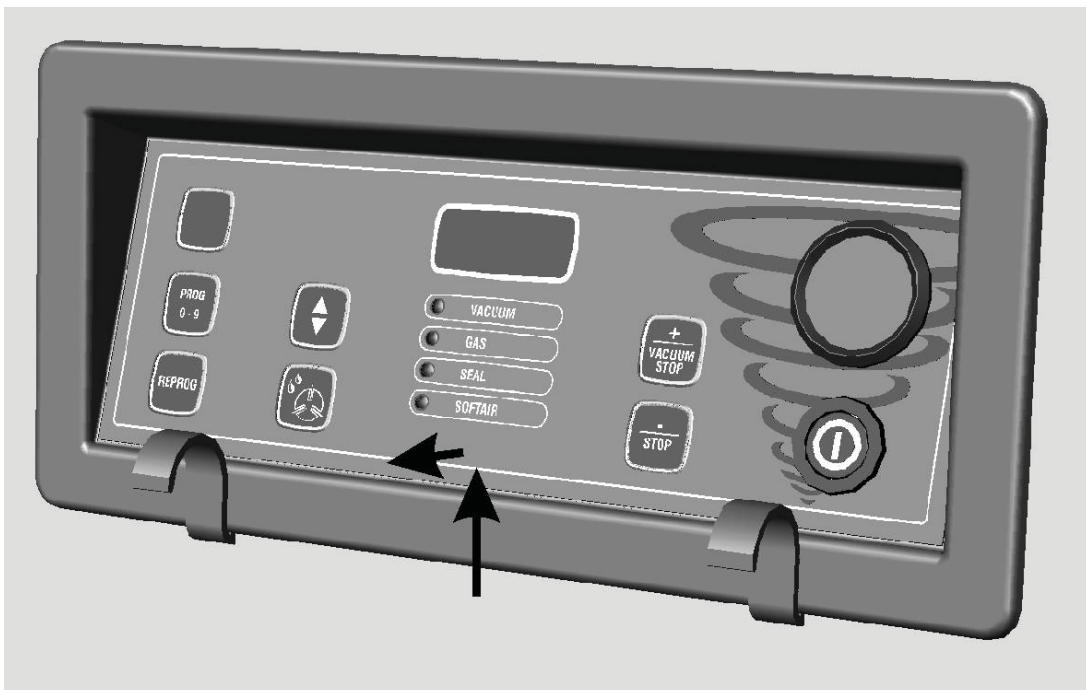
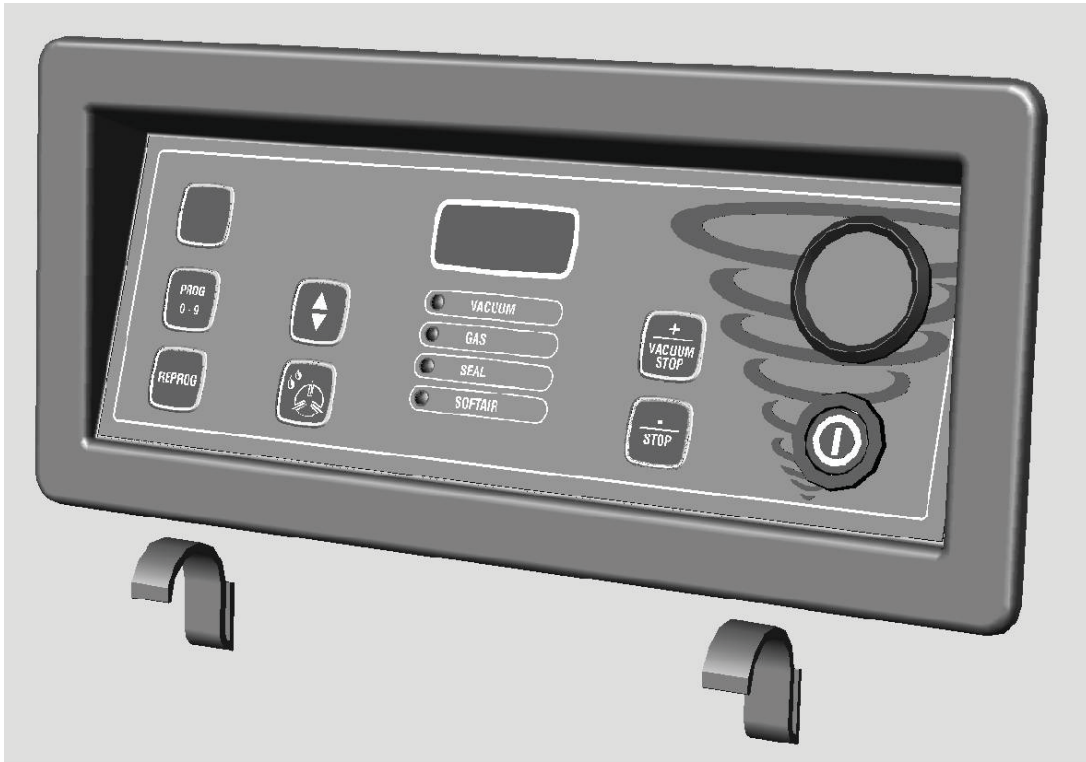

NATIONAL HEAD OFFICE

156 Swann Drive, Derrimut, VIC 3030

Phone: 03 8369 4600

Fax: 03 8369 4699

Email: sales@comcater.com.au

EQUIPMENT SALES

Phone: 1800 035 327

Fax: 1800 808 954

VIC/TAS SALES SHOWROOM & DEMONSTRATION KITCHEN

96-100 Tope Street, South Melbourne, VIC 3205

Phone: 03 8369 4600

Fax: 03 8699 1299

Email: sales@comcater.com.au

NSW/ACT SALES SHOWROOM & DEMONSTRATION KITCHEN

Unit 20/4 Avenue Of The Americas, Newington, NSW 2127

Phone: 02 9748 3000

Fax: 02 9648 4762

Email: nswsales@comcater.com.au

QLD/NT SALES SHOWROOM & DEMONSTRATION KITCHEN

1/62 Borthwick Avenue, Murarrie, QLD 4172

Phone: 07 3399 3122

Fax: 07 3399 5311

Email: qldsales@comcater.com.au

WA SALES

Unit 4 / 35 Westchester Road, Malaga, WA 6090

Phone: 08 9248 9290

Fax: 08 9248 1903

Email: wasales@comcater.com.au

SA SALES

Phone: 0409 340 015

Email: sasales@comcater.com.au

EQUIPMENT SERVICING (24/7)

Phone: 1800 810 161

Fax: 03 8369 4696

Email: service@comcater.com.au

EQUIPMENT SPARE PARTS

Phone: 1300 739 996

Fax: 03 8369 4696

Email: spares@comcater.com.au

TECHNICAL PHONE SUPPORT

Phone: 1300 309 262

Fax: 03 8369 4696

Email: technicalsupport@comcater.com.au

www.comcater.com.au