

PureVac

USER MANUAL **REGAL SERIES**



1800 035 327
www.comcater.com.au
from the world of Comcater

COMCATER
- foodservice equipment

This manual is for the REGAL series. The general instructions apply to the models in this category. PureVac cannot be held responsible for any damage caused by deviating machine specifications.

This manual has been compiled with the utmost of care. PureVac accepts no responsibility for any errors in this manual and/or the results of misinterpretation of this manual.

PureVac is not liable for damages and/or problems that arise from using spare parts that are not supplied by PureVac

PureVac reserves the right to change specifications and/or spare parts without prior notification.

All rights reserved. No part of this publication may be reproduced by photocopy, printing or in any other way without prior consent from PureVac

LIABILITY

1. We exclude all liability in so far as it is not provided for by law.
2. Our liability shall never exceed the total amount of the order in question.
3. Barring the generally applicable legal rules of public order and good faith we are not liable to pay for any damage of any sort whatsoever, directly or indirectly, including business losses, to movable or immovable property, or to persons, either at the opposing party as at third parties.
4. We are in any case not liable for damages arising from or cause by the use of the product supplied or by the unsuitability of it for the goal for which the other party purchased it.

GUARANTEE

1. Subject to the following limitations we give 24 months guarantee on the products supplied by us. This guarantee is limited to manufacturing faults that occur and does therefore not cover breakdowns involving any parts of the supplied product that are exposed to any form of wear or usage.
2. The guarantee on parts or additions provided from third party suppliers is limited to the guarantee provided us by the third party supplier.
3. The guarantee expires if the other party and/or third parties engaged by him use the supplied product incompetently.
4. The guarantee also expires if the other party and/or third parties engaged by him carry out activities on i.e. make modifications to the supplied product.
5. If we replace parts in compliance with the obligations of this guarantee then the replaced parts become our property.
6. If the other party does not, not sufficiently, or not in a timely fashion fulfil any of the obligations arising from the agreement reached between the parties then we are not obliged to provide this guarantee as long as the situation is occurring.

The stipulations of the guarantee and liability are part of the general terms and conditions of sale which will be sent to you if requested.

CONTENT USER MANUAL

INTRODUCTION / LIABILITY / GUARANTEE	2
CONTENT USER MANUAL	3
MACHINE REGISTRATION	4
IMPORTANT FOR INSTALLATION – READ THIS FIRST !!!!	5
IMPORTANT FOR INSTALLATION – READ THIS FIRST !!!!	6
WARNING LABELS	6
IMPORTANT MACHINE PARTS	7
START UP AND OPERATION	8
	ON/OFF switch	8
	Start the machine	8
	Standard user operations	9
OPERATING PANEL	10
	Control panel version.	10
	Control panel layout	10
	Control panel use	11
MACHINE MAINTENANCE	12
	General	12
	Important before and during maintenance	12
	Standard maintenance schedule	13
	Vacuum pump maintenance	13-15
	Seal system maintenance	16-17
	Silicone holder and lid gasket maintenance	18
	List of maintenance parts	19
TECHNICAL SPECIFICATIONS	20
ELECTRICAL DIAGRAMS	20-21
	Error code	21
PNEUMATIC DIAGRAMS	22
PROBLEM SOLVING	23
REMARKS ON SPECIAL APPLICATIONS	24
	Packaging liquid products	24
	External vacuuming of food containers	25
MAINTENANCE SCHEDULE / NOTES	26
REMOVAL FRONT PANEL	27



PRIOR TO STARTING TO USE THE MACHINE, MACHINE REGISTRATION TO BE COMPLETED BY THE USER

Register the machine using the following data. This information is necessary if the supplier or PureVac is contacted concerning questions or references about the specific machine.

DATA ON MACHINE TAG

Relevant data for answering questions can be found on the machine tag. The machine tag is located at the rear of the machine. Note down the following data:

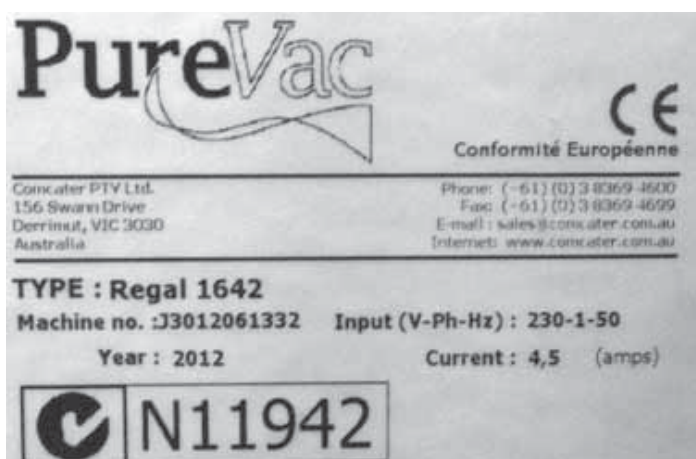

1. MACHINE TYPE

2. MACHINE NUMBER (MACHINE NO.)

3. VOLTAGE (TENSION)

CONTROL PANEL DATA

When starting the machine two codes first appear on the display in succession before control switches to user mode. The first code indicates the software version of the control software and the second code indicates the options active.

Write both codes in the space below:



4. CODE 1

5. CODE 2



IMPORTANT FOR INSTALLATION !!! READ THIS FIRST !!!

GENERAL

- First read this manual carefully before the machine is put into operation. This manual contains relevant information and instructions for starting up, maintenance and applications. If problems arise with the machine that could have been avoided by referring to this manual then the guarantee expires.
- PureVac wishes the customer lots of pleasure for an extended period from the purchase of the machine. If there are any problems or questions then the customer can always approach the supplier or PureVac.

ENVIRONMENT

- The machine must be moved or transported in an upright position. The machine may NOT be tilted as this can cause damage to the pump.
- Place the machine on a flat, level floor. This is essential for problem free operation of the machine.
- Enough space must be left around the machine for good ventilation. The space must be at least 5 centimetres.
- The ambient temperature in which the machine is operated must be between 5 0C and 30 0C. When operating the machine in other ambient temperatures the user must contact the supplier or PureVac for advice.
- NEVER place the machine directly next to a heat source or a steaming device (for example a combo-steamer, dishwasher or stove)

POWER / EARTH

- Check that the voltage stated on the machine tag is the same as the mains voltage.
- Always connect the machine correctly to an earthed socket to avoid danger for fire or electrical shocks (earth connection is green/yellow).
- The power cable must always be free and nothing may be placed on it.
- Replace the power cable immediately if damaged.
- Always disconnect the power if there are problems with the machine or during maintenance, prior to starting work on the machine.
- If the machine is stationary for long periods then the power should always be disconnected..

VACUUM PUMP

- Check before starting the machine if there is oil in the pump (see page 16). NEVER start the machine without oil in the pump.
- Use the right type of oil for the pump (see page 13).
- After moving and/or transporting the machine, always first check the oil level before re-starting operation.
- When starting the machine for the first time or after a lengthy idle period first run the conditioning programme before operating the machine (see page 13).



IMPORTANT FOR OPERATION !!! READ THIS FIRST !!!

GENERAL

- Never pack products that can be damaged during or after vacuum packaging. Live oats may never be vacuumed.
- Refer to this manual if in doubt as to the operation and/or functioning of the machine. If the manual does not offer a solution consult the supplier or PureVac.
- The guarantee and/or liability expires if damage is caused by repairs and/or changes made by you. In the case of malfunctions contact the supplier or PureVac.
- In the case of malfunctions always stop the machine and remove the power cable from the wall socket.

GENERAL MAINTENANCE

- It is essential that the machine is serviced regularly to guarantee operation and to keep the machine in optimal condition. The maintenance schedule is clearly defined on page 13. The guarantee automatically expires due to overdue or sloppy maintenance.
- Always remove the power cable from the wall socket for maintenance work, the machine must be completely disconnected.
- If there are doubts about the maintenance activities or if the machine fails to work correctly always contact the supplier or PureVac.

TRANSPARENT LID

- Never locate the machine near a heat source. This can cause damage to the lid (cracks).
- Never place hot, sharp, or heavy objects on the lid. These can cause damage to the cover (cracks) in the long run.
- Always clean the cover with solvent-free cleaning agents. Solvents can damage the lid.
- Check at least once a week if there are cracks in the lid. If cracks are visible in the lid then the machine must IMMEDIATELY be turned off and not used again until the lid has been replaced. Continuing to work with a cracked lid can cause the lid to implode. All guarantees and/or liability expire in the case of accidents and/or damage caused by working with a cracked lid.
- Replace the transparent cover every 4 years as a precautionary measure as a standard maintenance interval.

VACUUM PUMP

- Regularly check the level and quality of the oil in the pump. If too little oil or the quality of the oil is bad (turbid), replace or top up the oil before operating the machine (see page 16). Let the pump conditioning program run at least one full cycle before replacing the oil (see page 13).
- Use the right type of oil for the pump when replacing or topping up (see page 17).
- Use the conditioning program at least once a week to enhance correct and long-lasting pump operation (see page 13).



WARNING SIGNS ON THE MACHINE !!!



- ONLY use the prescribed power supply voltage.
- Insert the plug firmly into the mains wall socket.
- Always connect the machine to an earthed wall socket.
- Always remove the plug during maintenance or when the machine is not in use for extended periods.

IMPORTANT MACHINE PARTS

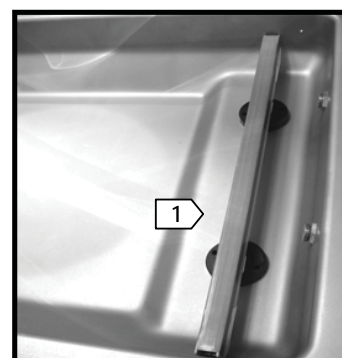

Vacuum chamber

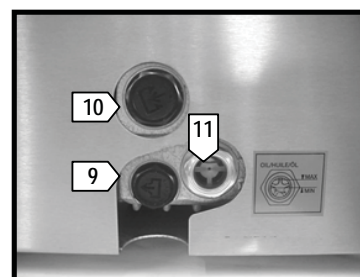

Side view Regal 0835 and Regal 1642

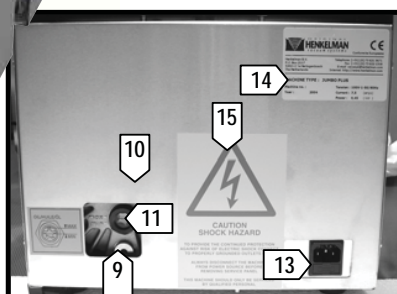

Rear view Regal 0428

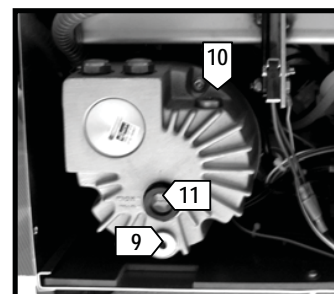

Rear view Regal 0428 with cover removed

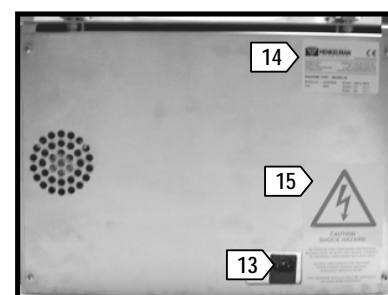

Side view Regal 0835 and Regal 1642

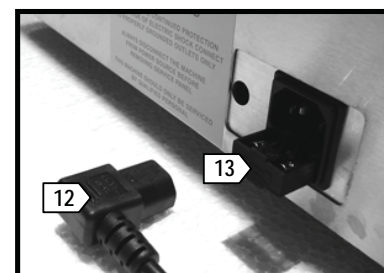

Fuse holder and cable

1. Sealing bar in vacuum chamber mounted sealing supports with a click system or screws
2. Silicone holder mounted on transparent lid
3. Lid gasket in lid for hermetic seal
4. Gas springs for opening lid after machine cycle (Regal 0428 / Regal 0835 1 gas spring in the middle)
5. Vacuum / Ventilation opening
6. Control panel
7. Vacuum pressure meter
8. ON/OFF Switch
9. Oil drain plug
10. Oil fill plug
11. Oil inspection window
12. Power cable
13. Fuse holder with fuses
14. Machine tag
15. Warning stickers

Appearance of parts and machines can deviate per model from illustrations

STARTING AND OPERATING THE MACHINE

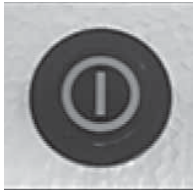

ON/OFF SWITCH

The ON/OFF switch is used to turn the machine on and off before and after operation.

CAUTION – The ON/OFF switch does not completely remove all power from the machine. The power cable must be unplugged from the wall socket to remove all power from the machine. Ensure that the machine is completely without power during maintenance and repair activities is.

When the machine is turned on (with the ON/OFF switch), then the pump only runs during the vacuum cycle.

START MACHINE

When the machine is connected, then the machine can be turned on using the ON/OFF switch. When starting the machine two codes first appear in succession on the display before control switches to user mode.



The first code indicates the control software version. The second code indicates the machines active options. Note both codes on page 4 of this manual as they are important for the supplier or PureVac when making enquiries and/or if any problems arise.



After switching to user mode the machine is ready for use. If the machine is new or has not been used for an extended period, then it is important to run the conditioning program for the pump (15 minutes) to maintain the pump. For instructions on the conditioning programme, see page 13.



After switching to the user mode the display could read [OIL]. This means that the operating hours counter is turned on and the set number of operating hours has elapsed. The hour counter is turned off by default but the client supplier can use it as a reminder for regular maintenance activities.



When [Oil] is displayed the machine can be still be used as usual but it is advisable to either turn off the hour counter or to reset it.

Contact the supplier or PureVac for more information about setting or turning off the operating hours counter.

STANDARD USER OPERATIONS FOR THE MACHINE

1. Turn the machine on with the ON/OFF switch. Warm the pump up with the condition programme if the machine has stood idle for some time (instructions page 13).
2. Fill the vacuum bag with product. Select the correct format bag that easily fits around the product but is not too large for the product. Ensure hygienic conditions during this operation. Packaging materials, product and hands must be clean and if possible dry.
3. Lay the vacuum bag in the chamber. The open side must be laid over the sealing bar. The bag may however not extrude from the chamber. If the product is a lot lower than the height of the sealing bar then insertplates that are supplied standard with the machine can be used. This makes the operation easier and reduces the cycle time.
4. The vacuum bag must be placed over the sealing bar without any folds.
5. Multiple vacuum bags can be placed over the sealing bar if the sealing bar is longer than the opening of the vacuum bag. Vacuum bags may not however be laid on top of each other on the bar.
6. Set the correct value for vacuum and sealing functions. See page 11 for setting the function values.
7. Close the lid and the machine automatically runs through the full cycle of installed functions. The lid opens automatically when the last function "ventilation" has finished.
8. If necessary the cycle can be fully or partially interrupted by pressing the [VACUUM STOP] key or the [STOP] key. The [VACUUM STOP] key interrupts the active function (vacuum or sealing) and automatically continues with the next function. The [STOP] key interrupts the entire cycle and goes immediately to the ventilation function.
9. The packed product can be removed from the machine.



SAFETY and PRODUCT PROTECTION

The packing process can be partially or fully interrupted at all times:

- Stop active function, press on [VACUUM STOP] key
- Stop full machine cycle, press [STOP] key

OPTIMAL AND EFFICIENT PACKAGING RESULT

- Use the correct format and good quality vacuum bags
- Maximum 75% product filling in vacuum bag
- Place vacuum bag fold free over seal beam (use correct number in inlay plates in chamber)

CONTROL PANEL

DIGITALE TIME CONTROL

The digital control is implemented with a function program that can be set with different function values per cycle (to be able to pack different products). A program cycle is the complete program of set functions (vacuum and seal) that the machine runs through to package a product.

The control panel is implemented standard with a conditioning program for the regular maintenance of the pump and two STOP keys for complete function interruption or for only active function interruption. There are also a number of built-in service programs. Contact the supplier or PureVac for more information about these functions.

The value of the functions can be set for a certain time period.

The vacuum function can be set to whole seconds with a maximum of 99 seconds.

The seal function can be set with an interval of 0.1 seconds and a maximum of 6.0 seconds.

CONTROL PANEL LAYOUT

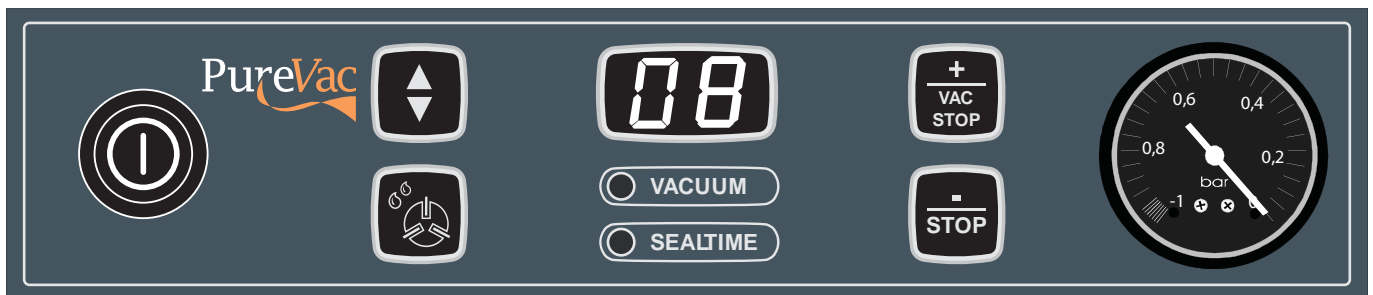

1. DISPLAY

Displays the status of the active function during the run of the program cycle or the set value of the selected function when machine is not running.

2. FUNCTION SELECTION KEY

Select function (vacuum or seal) for viewing or changing function values. The function is selected if the function light is on in front of the function description under the display.

3. CONDITIONING PROGRAMME KEY

Start the conditioning program for pump (duration 15 minutes). For instructions on the program, see page 13.

4. FUNCTION LIGHTS

A light in front of the function indicates that the function is active during the program cycle or that the function is selected for view or change

5. + / STOP VACUUM KEY

Function during cycle: Interruption of the active function during the program cycle. The cycle immediately continues with the next function. General function. Increment the value of the selected function.

6. - / STOP KEY

Function during cycle: Terminates the program cycle completely. The cycle immediately switches into the ventilation function. General function Decrement the value of the selected function.

7. VACUUM METER

Displays the pressure in the vacuum chamber.

8. ON/OFF SWITCH

The ON/OFF switch is used to turn the machine on and off before and after operation. The switch turns on all units in the machine. Caution, the switch does not completely remove all power from the machine.

CONTROL PANEL USE

When the machine is turned on it is ready for use once the two operating codes have displayed.

DESCRIPTION OF THE PROGRAM CYCLE FOR DIGITAL TIME CONTROL

1. Functions (vacuum and sealing) are set with the correct values (see page below for settings)
2. **Close the lid.**
3. **Vacuum function:** The machine starts to vacuum the chamber.
The light in front of [VACUUM] goes on.
Display : decrementing time per second starting at the time set (max. 99 sec.).
Vacuum meter starts increasing to the left.
4. **Sealing function:** Once the vacuum function is finished, the sealing function starts to seal the vacuum bag(s).
The light in front of [SEAL] goes on.
Display : decrementing time per 0.1 second starting at the time set (max. 6.0 sec.).
The reading on the vacuum meter stays the same.
5. **Ventilating function:** After ending the seal function the ventilating function starts ventilating the chamber to 1 atmosphere/ATO and the lid opens.
There are no longer any lights on in front of the functions.
Display : lines moving up and down until the lid is opened.
The vacuum meter runs back to the right to zero and the lid opens automatically
6. **The product is packed and ready to remove.**

SET/CHANGE FUNCTION VALUES

The following steps must be followed to change the function values for vacuum and/or seal :

Press the FUNCTION SELECT Key to select the required function. The function light will light up when the function is selected.

Press the [+ / STOP VACUUM] or [- / STOP] keys for incrementing or decrementing the function values respectively. It takes 0.5 seconds before the value begins to change.

After changing the value(s) the machine must run through the cycle once (see previous page) to record the values.

VACUUM FUNCTION

The vacuum function value can be incremented or decremented per second with a maximum of 99 seconds and a minimum of 2 seconds.

If while changing the vacuum function setting the [+ / STOP VACUUM] or [- / STOP] key is held down then the first 5 seconds will be incremented or decremented per second. Then intervals of 10 seconds will appear. If the key is released then the settings can be changed again per second.

SEALING FUNCTION

The seal function setting can be increased or decreased with a maximum of 6.0 sec. and a minimum of 0.5 sec.

If while changing the seal function setting the [+ / STOP VACUUM] or [- / STOP] key is held down then the first 0.5 seconds will be incremented or decremented per 0.1 second. Then intervals of 1.0 second will appear. If the key is released then the settings can be changed again per 0.1 second.

SERVICE PROGRAMS CONTROL PANEL

The control panel is also equipped with a number of service programs that can be useful during regular maintenance or repairs. The conditioning program for the pump is the most used service program (see explanation on page 13). Contact the supplier or PureVac for more information about the use of other service programs.

MACHINE MAINTENANCE

GENERAL

Regular, thorough maintenance is essential for extending the machine's life, for preventing malfunctions and for achieving an optimal packaging result. If the machine is used intensively (more than 5 hours per day) then it is a professional service is recommended every 6 months. In other cases one complete service per year is sufficient (depending on location, environment and products).

There are however also small maintenance activities that must be carried out more regularly and that the user can do himself. The following page contains an overview of these activities.



IMPORTANT BEFORE AND DURING MAINTENANCE

- The machine must always be completely voltage free before any maintenance is carried out on it. Always remove the plug from the wall socket.
- If the machine is not functioning properly or if it produces strange noises, turn it off immediately with the ON/OFF switch and contact the supplier or PureVac.
- When cleaning transparent lids NEVER use cleaning agents containing solvents. Check at least once a week if there are cracks in the lid. In case of cracks, turn off the machine immediately and contact the supplier or PureVac.
- High pressure cleaning is not permitted for cleaning the machine. High pressure cleaning can cause considerable damage to electronic and other parts of the machine.
- Water may never be permitted to enter either the extraction nozzle of the chamber or the blow-off hole of the pump. This would cause irreparable damage to the pump.
- Larger services must always be carried out by an authorised supplier.
- The Regal machines are designed for a maximum of 5 hours per day. The supplier or PureVac cannot be held responsible for any malfunctions or defects if these operating limits are clearly exceeded without consultation.
- The machine must be moved or transported in an upright position. The machine may NOT be tilted as this can cause damage to the pump.
- The supplier or PureVac cannot be held responsible for any malfunctions or defects if the maintenance instructions in this manual are not followed.

MACHINE MAINTENANCE

STANDARD MAINTENANCE SCHEDULE FOR THE MACHINE

- | | |
|-------------------------|---|
| Daily | <ul style="list-style-type: none"> • Clean the vacuum chamber, lid and housing after use with a damp cloth. • Be careful that no cleaning agents containing solvents are used. • Make sure that no high pressure cleaner is used. |
| Weekly | <ul style="list-style-type: none"> • Check the oil level and replace or top up oil if the oil is turbid or the oil level is too low. For instructions, see page 14. • Activate the conditioning program for the pump at least once a week. • Check the seal beam for damage. Replace teflon tape/seal wire if the seal quality is no longer sufficient or if the teflon tape/seal wire is no longer taught on the bar. For instructions, see page 16-17. • Check the lid gasket and replace it if the gasket is damaged or stretched. For instructions, see page 15-16. • Inspect the transparent lid for cracks. If cracks are visible, turn off the machine immediately and contact the supplier or PureVac. |
| Every Six Months | <ul style="list-style-type: none"> • Replace oil at least once every 6 months. |
| Yearly | <ul style="list-style-type: none"> • Inspect the oil exhaust filter for saturation. If saturated, replace the filter. For instructions, see page 15-16. • Contact the supplier for a professional service |
| Four-yearly | <ul style="list-style-type: none"> • Replace transparent lid and the gas springs • Replace seal cylinder membranes. |

VACUUM PUMP MAINTENANCE

It is very important to regularly service the pump to ensure extended and correct operation. The following activities are essential for correct maintenance. If the machine is used regularly then it is advisable to have the pump fully inspected at least once a year by the supplier to ensure extended and problem free operation. Contact the supplier or PureVac for more advice and information.



CONDITIONING PROGRAM

The conditioning program ensures that the pump is thoroughly rinsed. During the programme the pump and oil reaches operating temperature so that the oil can better absorb any moisture and contaminants and filter them. The high temperature enables any moisture in the pump to evaporate minimising the risk for corrosion in the pump.

The program lasts 15 minutes and it is advisable to run it at least once a week. Turn on the machine, press the key [conditioning program], and close the lid. The program runs automatically. During the program the display will display moving dots.

The program can be interrupted at any time using the [STOP] key. It is however important for the sake of good maintenance that the program completes a full 15 minute cycle and therefore advisable only to interrupt the cycle for something urgent.

It is also advisable to run the program before using the machine for the first time, after the machine has been stationary for a lengthy period of time, and especially prior to changing oil.

CHANGING OIL / FILLING UP

The oil level and oil quality must be checked at least once a week. The oil inspection window serves this purpose. Top up the oil level if it is too low. Replace the oil if it is turbid. Oil must be replaced at least once every 6 months.

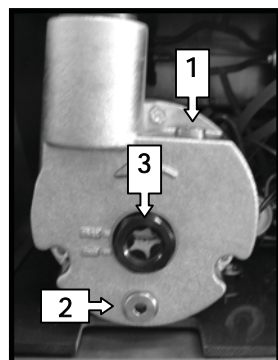

Rear view Regal 0428
after opening rear end.

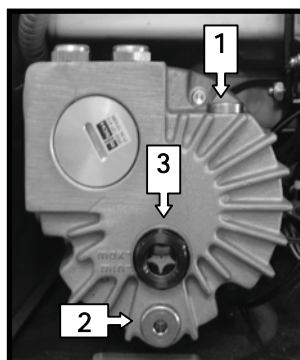

Rear view Regal 0835 and
Regal 1642 after opening
rear end.

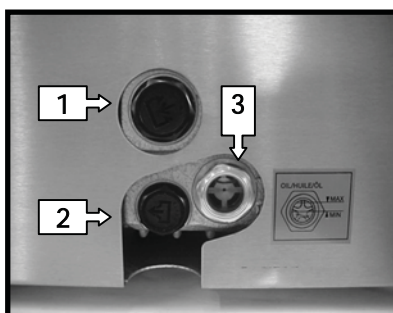

Side view Regal 0835 / Regal 1642

1. Oil fill plug
2. Oil drain plug
3. Oil inspection window



Take care to use the correct type of oil for the pump
Beware of hot oil fumes during drainage

DRAINING OIL

If the oil is white or turbid when checked then it must be replaced. Before draining off the oil let the conditioning program run a full cycle. The dirt and moisture is absorbed by the oil and the oil becomes thinner making draining easier.

After the program has ended the drainage plug can be removed.

CAUTION

When unscrewing hot oil fumes can escape. The oil now drains from the drain hole (an oil pan must be placed underneath). When the oil has drained, tilt the machine slightly so that all residual oil can drain off. After draining the oil drain plug is replaced.

FILLING UP OIL

After draining or if the oil level has dropped, oil needs to be filled up. The oil fill plug must be removed with the correct size spanner. The pump can now be filled with oil. Make sure that you add the correct amount (see table on page 15) For the models Regal 0428 and Regal 0835, slide the component plate backwards to facilitate filling.

TAKE CARE to fill with small amounts at intervals. Fill the oil level to the top of the oil level indicator sticker.

OIL TYPES AND AMOUNTS

It is important to use the correct type and quantity of oil for the pump. The wrong type or too much oil could damage the pump. The ambient temperature where the machine is operated is also important for the type of oil. See amounts and types with related ambient temperatures in the table on the next page.

Examples of supplier brands for the standard types of oil are Shell Vitrea, Aral Motanol GM, BP Energol CS, or Texaco Regal R+ O with related viscosity numbering. If the machine is used outside normal specifications regarding ambient temperature, contact the supplier or PureVac

Machine Type	Pump Capacity	Filling (litres)	Standard Oil type 10 - 30 °C	“Cold” Oil type 5 - 10 °C	“Hot” Oil type 30 - 40 °C
Regal 0428	004 m ³ /h	0.05	Viscosity VG 22	VM 22	VS 22
Regal 0835	008 m ³ /h	0.2	Viscosity VG 32	VM 32	VS 32
Regal 1642	016 m ³ /h	0.3	Viscosity VG 32	VM 32	VS 32

Machines are supplied with standard type oil.

INSPECT AND CHANGE OIL EXHAUST FILTER

There is an oil exhaust filter in the pump that absorb and filter oil vapours. The filter will become saturated after a period of time and needs to be replaced. This is on average between 9 and 18 months. When the filter is saturated it is no longer possible to achieve maximum vacuum and the machine starts smoking.

OIL EXHAUST FILTER HOUSING TYPES

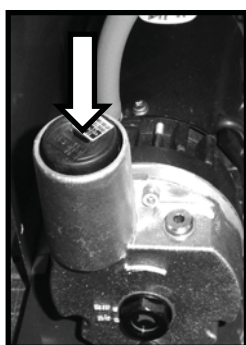

Regal 0428

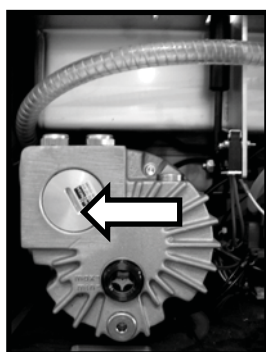

Regal 0835

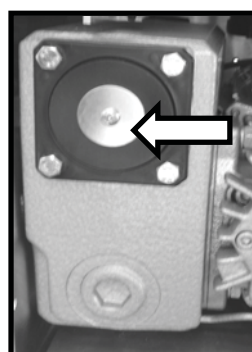

Regal 1642

- Filter housings are at the rear of the machine.

CHANGE OIL EXHAUST FILTER Regal 0428 / Regal 0835 & Regal 1642

Regal 0428



Regal 0835
Regal 1642

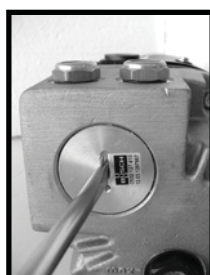

Open the back
Slide the component
board to the back
Unscrew the filter

Remove the old filter
from the housing
Place the new filter in
the housing.
Screw the filter on again

Take care that the filter
gasket does not remain
behind when removing
the filter.
Take care that the filter
gasket is correctly
placed on the new filter.

CHANGE OIL EXHAUST FILTER Regal 0835 / Regal 1642



Open the rear of machine for the pump



Unscrew the cover from the filter housing



The filter is visible clamped behind a tensioner



Release the tensioner with a spanner



Remove tensioner and filter from the housing



Ensure that the sealing ring does not remain behind when removing the filter

- Position and clamp the new filter (ensure that the seal ring is in position) in the housing.
- Screw the cover back onto the housing.
- Screw the back plate back onto the machine.

- Pumps and housing can have a different appearance but the principle of replacing them remains the same.
- Take care that the correct type of filter is used for the pump type, see page 20 for correct type of filter for the type of pump.
- It is advisable to have the supplier do this service.

SEAL SYSTEM MAINTENANCE



DOUBLE SEAL
2 x 3.5 mm seal

The seal system for the Regal series is a double 3.5 mm convex sealing wire.

The seal quality is partially dependent on the maintenance of the sealing bar and silicone holder. The main maintenance activities are the daily cleaning of the sealing bar and silicone holder with a damp cloth and a weekly inspection of the bars with replacement of the sealing wire, teflon tape or silicone rubber if irregularities appear on top of the bar or the seal quality is insufficient. The models Regal 0428 and Regal 0835 are equipped with a hard-tissue sealing bar with clamps on both sides of the sealing beam. The sealing bar is attached to the holders with screws.

The models Regal 35 and Regal 1642 are equipped with an anodised aluminium sealing bar with clamps on the bottom of the sealing bar. The sealing bar is clicked to the holders.

The steps for replacing the sealing wire and teflon tape are described on the following pages. The appearance may differ but the procedure remains the same.

The average maintenance cycle of the sealing bar (teflon tape / sealing wire) is **at least once every 3 months.** (This indication refers to regular use of the machine and packaging standard products with standard vacuum packaging materials. No rights can be derived from this indication)

REPLACE SEALING WIRE AND TEFLON TAPE Regal 0835 AND Regal 1642 (DOUBLE SEAL)

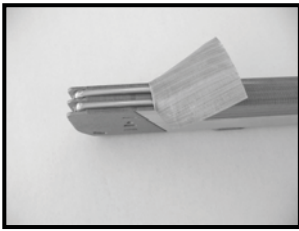

Remove teflon tape

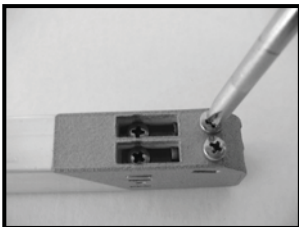

Unscrew and remove sealing wires

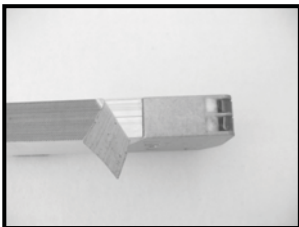

Replace the teflon tape

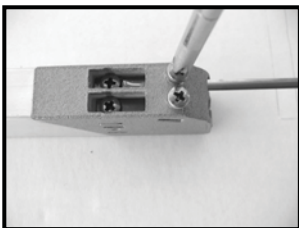

Screw down new wires onto clamping plate



Pull wires taught using a pair of pliers and a vice and screw the wires down on the clamping plate.



1. Remove the sealing bar from the holder by releasing the click system.
2. Remove the teflon tape from the sealing bar.
3. The old sealing wires and cut-off wires (if applicable) can be removed by unscrewing the clamp (see illustration) and pulling the wires from the grooves.
4. Remove the teflon tape that is attached to the top of the sealing bar and stick a new piece of teflon tape to the bar of the same length after having degreased and cleaned the bar with a dust free cloth.
5. Cut a new piece of sealing wire or cut-off wire to the size of the sealing beam plus about 15 cm (± 6 inches). If 2 sealing wires or an extra cut-off wire is on the sealing beam then a second sealing wire or cut-off wire must of course be cut.
6. Place the end of the wire or wires through the groove(s) on the side of the sealing beam and screw the wires to the bottom.
7. Place the sealing bar top down in a vice and pull the sealing wire or wires through the other side of the groove(s) on the sealing beam.
8. Pull the wires tight with a pair of pliers and screw them down at the same time. Ensure that the wire (wires) is (are) pulled taught and straight with the help of a pair of pliers before the wires are screwed down.
9. It is handy to use a pair of adjustable pliers as a lever for optimal wire tension. Place one end of the sealing beam in the vice and stretch the wire (wires) by pressing down the bar.
10. Cut off the extruding wire end(s) on both ends after having screwed it tight.
11. Cut a piece of teflon tape as long as the sealing bar plus about 5 cm (± 2 inches).
12. Stick the new teflon tape straight over the new sealing wire (wires). Ensure that the teflon is straight on the sealing bar and that the sticky part is stuck on the side. Ensure that the teflon is stuck on the bar smoothly and without folds.
13. Cut the teflon tape off so that the sticky part does not get stuck on the sides of the clamps but that the teflon extends over the top of the clamps.
14. Place the sealing bar back in the machine. Ensure that the sealing beam is properly clicked onto the holders or that the screws are firmly screwed in.

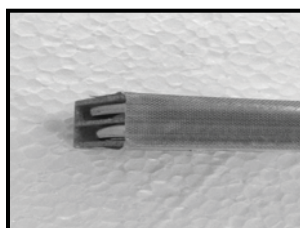

**See page 20
for correct parts and quantities**

Cut off the ends of the sealing wire and stick Teflon tape over the sealing beam without folds

SILICONE HOLDER AND LID GASKET MAINTENANCE

REPLACE THE RUBBER SILICONE HOLDER

The silicone holder must be inspected weekly for roughness on the silicone rubber (mainly caused by burning by the sealing wire). If irregularities appear then the silicone rubber must be replaced.

Average maintenance cycle for silicone rubber is **at least once every 6 months**

(This indication refers to regular use of the machine with standard products. No rights can be derived from this indication)

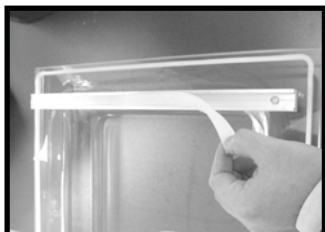

Appearance may differ per model
but principle remains the same.

1. Remove the old silicone rubber from the holder.
2. Cut a new piece of silicone rubber the same size as the old one. The same size is very important, too short or too long will cause problems with sealing.
3. Place the new piece in the silicone holder. Ensure that the silicone rubber is completely and evenly placed in the groove. It is also important that the surface of the silicone rubber is smooth after it is in place and it shows no signs of tension.

REPLACE LID GASKET

The lid gasket ensures that the vacuum chamber is completely sealed during the machine cycle. This is essential to achieve a maximum vacuum. The lid gasket wears due to the extreme pressure differences and must be replaced regularly. Inspect the lid rubber weekly for tears or damage.

Average maintenance cycle for silicone rubber is **at least once every 6 months**

(this indication refers to regular use of the machine, on average 5 hours a day and with standard products. No rights can be derived from this indication)

The length of the new lid gasket is measured against the old rubber. If the lid gasket is too short or too long it can cause problems closing the lid or leak.

The gasket must be placed evenly and without tension in the holder. The ends must be cut straight and must be laid tightly against each other to avoid leakage.

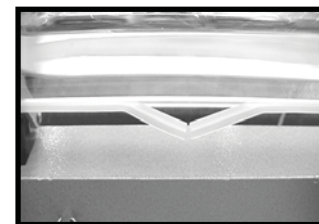

Ensure that the ends of the lid
gasket line up accurately

Lid rubbers can vary per
model, see page 18

LIST OF SERVICE PARTS

VACUUM PUMP PARTS

BUSCH VACUUM PUMPS	PureVac MODELS
004m ³ /h	Regal 0428
008 m ³ /h	Regal 0835
016 m ³ /h	Regal 1642

BUSCH	STANDARD OIL			OIL EXHAUST FILTER		
	Type	PureVac Reference	Litres	Type	PureVac Reference	Amount
004m ³ /h	VG 22	0439501	0.05	50-60Hz	0939000	1
008 m ³ /h	VG 32	0439510	0.20	50-60Hz	0939001	1
016 m ³ /h	VG 32	0439510	0.30	50-60Hz	0939003	1

SEAL SYSTEMS

PARTS	SPECIFICATIONS	PureVac Reference	QUANTITY
Teflon tape	46 mm teflon tape	0305515	length sealing bar + 5 cm
Double seal	2 x 3.5 mm round wire	0305000	1 wire length of sealing bar + 15 cm
Silicone Rubber	Silicone 17 x 8	0320200	length silicone holder

LID GASKET

MODELS	PureVac REFERENCE	LENGTHS PER MODEL (in cm)	
Regal 0428 / Regal 0835	0320100	Regal 0428 / Regal 0835	140
Regal 0835 / Regal 1642	0320215	Regal 0835 Regal 1642	175 190

Lengths specified are always a little longer and must be cut to the correct length.

TECHNICAL SPECIFICATIONS

MODEL	VACUUM CHAMBER	LID	HOUSING	DIMENSIONS (mm)	PUMP (m ³ /h)	FINAL VACUUM (%)
Regal 0428	Stainless-steel	Transparent	Stainless-steel	330 x 450 x 295	004	99,80%
Regal 0835	Stainless-steel	Transparent	Stainless-steel	450 x 525 x 385	008	99,80%
Regal 1642	Stainless-steel	Transparent	Stainless-steel	490 x 525 x 430	016	99,80%

Specifications may deviate with optional models

Standard ambient temperature	5°C – 30°C
For deviating ambient temperatures	see page 15 for special oil specifications
Maximum use per day	5 hours
Electricity	Voltage: see machine tag
	Frequency: see machine tag
	Power: see machine tag
Electrical connection	Maximum fluctuation ± 10% of the official registered voltage
Sound level	< 70 DB

ELECTRICAL DIAGRAMS

CONTROL CURRENT DIAGRAM

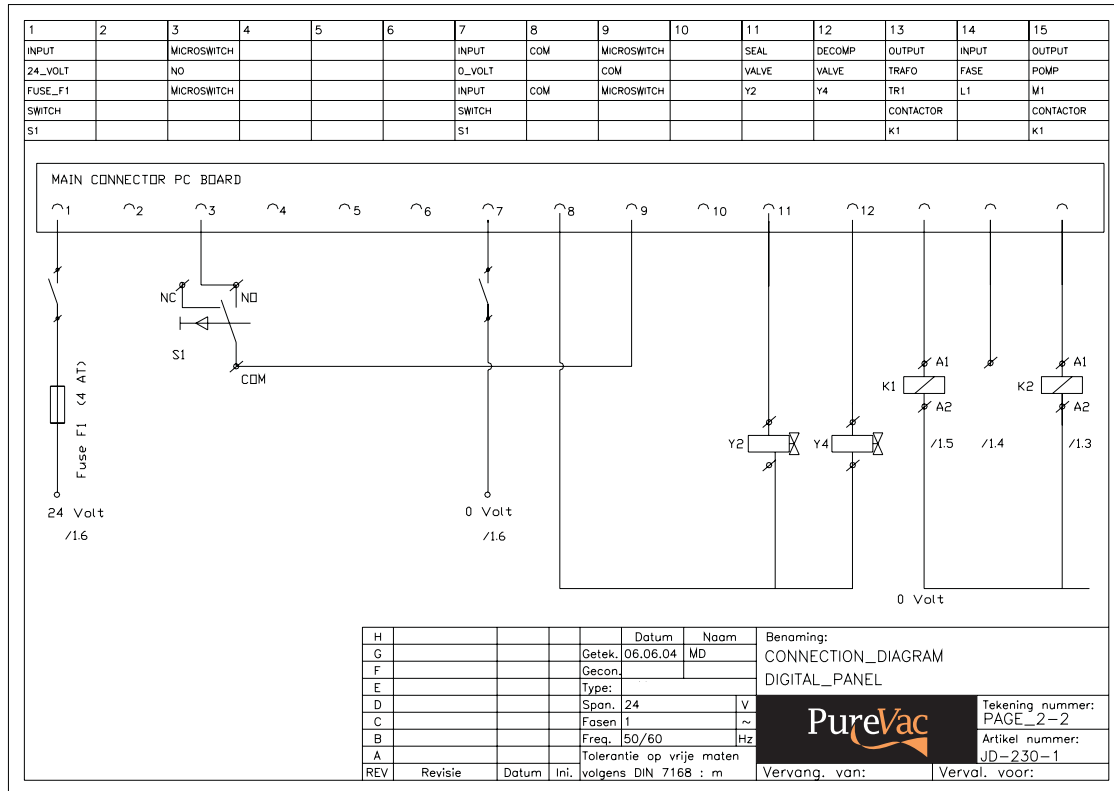

MAIN CURRENT DIAGRAM

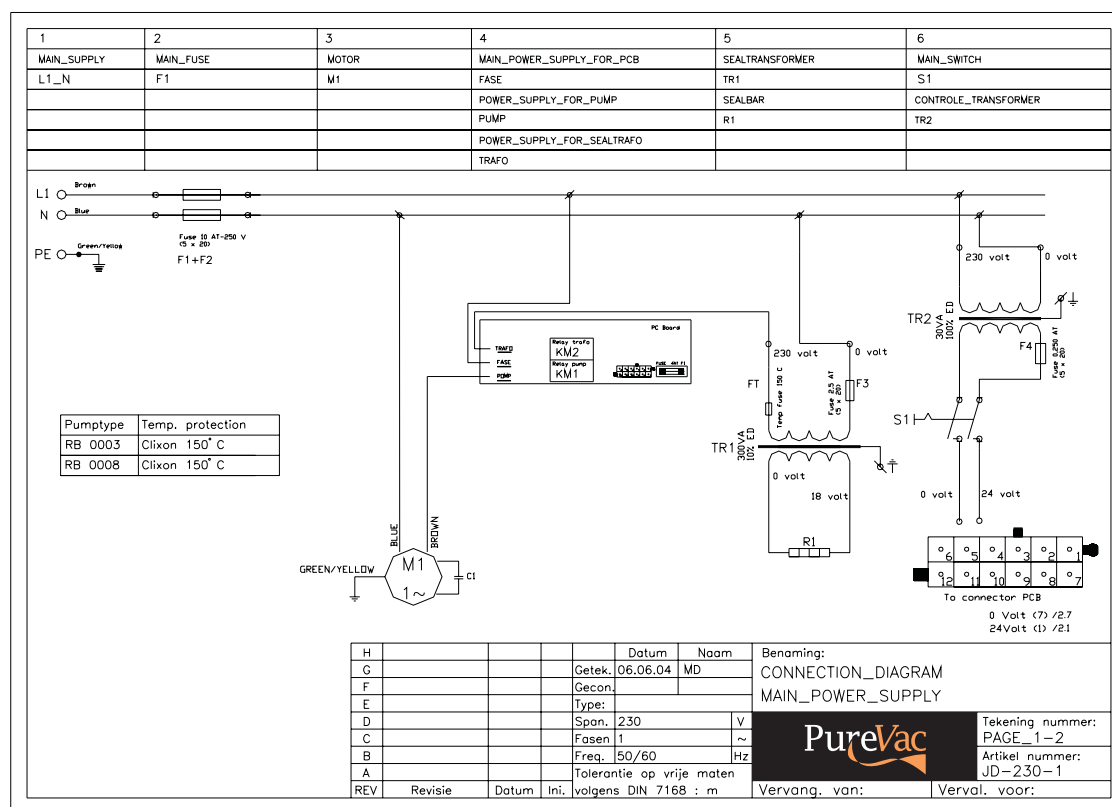

Diagrams are shown for standard configurations.

LIST OF FUSES

- Fuses have been placed where the power comes onto the component board
- Fuses have been placed on transformers (control and seal)
- Two fuses have been placed on the control circuit.

Due to different mains voltages and machine models there is a variety of fuse types that can be present in the machine. Refer to the specifications of the relevant component for the correct types and values of fuses for replacement, or contact the supplier or PureVac.



Caution, to avoid fire and/or other irreparable damage to the machine, replacement fuses must always be of the same type with the same value as the fuses being replaced !!

SPANNING



Caution, the maximum allowable voltage fluctuation is ± 10% of the official voltage stated on the type tag.

ERROR CODES

The control is programmed with an error code. This error code indicates there is a problem with the proper function of the lid switch of there is a user fault.

F1: This code indicates that the cycle (lid switch) will be interrupted prematurely.

Example: the cover of the machine closes after starting, but before sufficient vacuum is present to keep the cover closed the operator lets go of the cover. The F1 code will now be shown on the display.

If this keeps happening please contact the supplier or your dealer

PNEUMATIC DIAGRAM

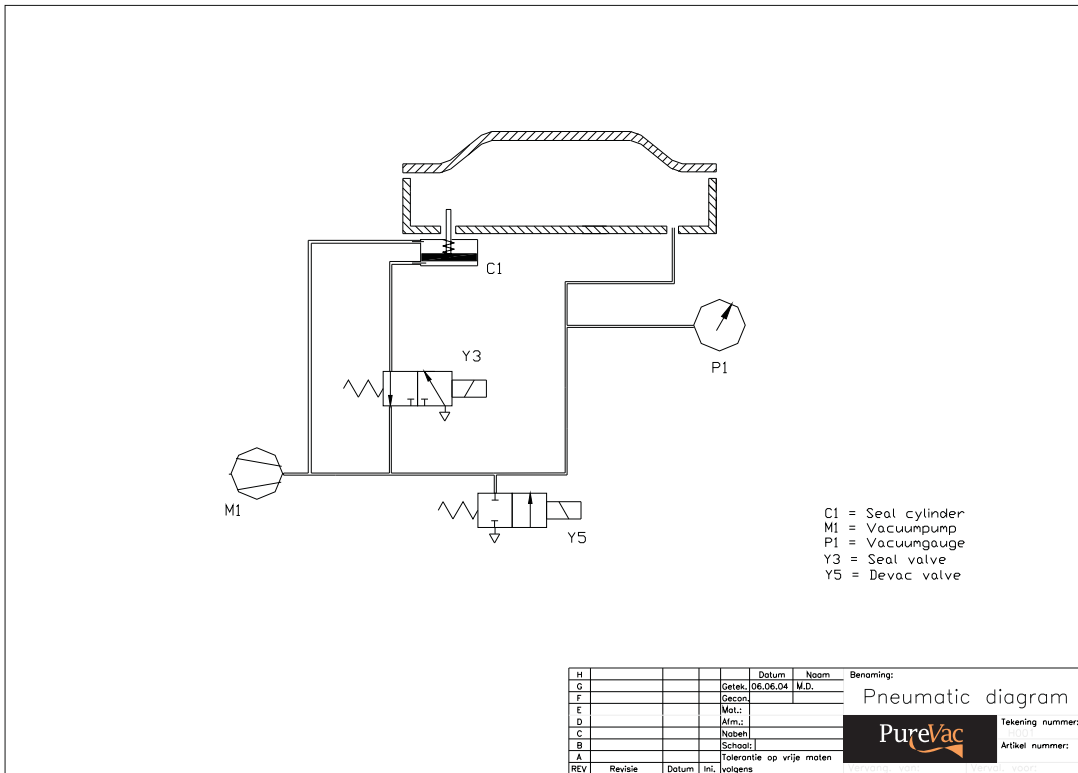

Diagrams are shown for standard configurations.

PROBLEM SOLVING

PROBLEM	CAUSE	SOLUTION
Machine does not work	<ul style="list-style-type: none"> • The plug is not plugged into the wall socket. • The main fuse is burnt. • The ON/OFF switch's contact block has come loose. • The circuit board fuse is burnt. 	<ul style="list-style-type: none"> • Plug the plug into the wall socket. • Replace the fuse (Ensure the correct value). • Check this and if necessary re-fasten it. • Disassemble the front panel and replace the fuse.
Machine does not work Operating panel is on	<ul style="list-style-type: none"> • The control transformer fuse is burnt. • The micro-switch that is activated when the lid is closed is disordered or faulty. • There is an internal malfunction. 	<ul style="list-style-type: none"> • Check this and if necessary replace it. • The micro-switch must be properly adjusted or replaced • Consult the supplier.
Transparent lid does not open automatically	<ul style="list-style-type: none"> • The gas spring is faulty 	<ul style="list-style-type: none"> • Consult the supplier.
Final vacuum is insufficient	<ul style="list-style-type: none"> • The set vacuum time is too short. • There is too little oil in the vacuum pump. • The extraction hole at the back of the vacuum chamber is partially covered by the vacuum bag during extraction • The lid gasket is worn. • The oil is contaminated • The oil exhaust filter is saturated. 	<ul style="list-style-type: none"> • Extend the vacuum time. • Check the oil level and top up if necessary (Note the type and quantity). • Place the vacuum bag closer to the sealing beam. • Replace the lid gasket. • Replace the oil (Note the type & amount). • Replace the oil exhaust filter / Consult the supplier.
The machine builds up a vacuum slowly	<ul style="list-style-type: none"> • The pump's extraction filter is blocked. • The oil exhaust filter is saturated. 	
The vacuum bag is not properly and/or correctly sealed.	<ul style="list-style-type: none"> • The vacuum bag is being placed incorrect on the sealing bar. • The sealing time is too long or too short. • The silicone rubber in the silicone holder is damaged or worn. • The teflon tape is damaged. • The inside of the vacuum bag opening is contaminated or greased. 	<ul style="list-style-type: none"> • Place the vacuum bag neatly and smoothly on the sealing bar. Ensure that the opening of the bag is always within the vacuum chamber. • Adjust the sealing time longer or shorter. • Replace the silicone rubber. • Replace the Teflon tape • Clean the vacuum bag's opening.

REMARKS ON SPECIAL APPLICATIONS

PACKAGING LIQUID PRODUCTS

The machines can be also used for packaging liquid products like soups or sauces. During this process the vacuum process must be carefully monitored through the lid. The [STOP VACUUM] key must be pressed as soon as bubbles appear in the product; the saturation point (same as boiling point) has then been reached.

The saturation point of liquids is reached at a certain ratio of low pressures and high temperatures (see the example table for water below). The saturation point will be reached sooner in the vacuum process when packaging liquids with a high temperature (the amount of vacuum will therefore be less).

PureVac recommends therefore to first cool liquid products before packaging. By so doing an optimal vacuum can be achieved for the product.

Saturation point of water – relation between the pressure and temperature of the water

Vacuum pressure [mbar]	1000	800	600	400	200	100	50	20	10	5	2
Boiling Point Temperature [°C]	100	94	86	76	60	45	33	18	7	-2	-13

A handy tip when packaging liquid products is to use a liquid insertplate so that the product remains at the bottom of the packaging during the vacuuming process and there is less risk of liquid splashing out of the packaging. Contact the supplier or PureVac for more information about the liquid insertplate.

EXTERNAL VACUUMING OF FOOD CONTAINERS (if applicable)

The Regal series can be equipped with an option for external vacuuming of special food containers. This system can vacuum special dishes for longer storage life of the (food) products in the dish. The dish has a special lid with valve. Contact the supplier or PureVac for more information about the dishes. The system for the machine consists of a hose with vacuum applicator.

OPERATION EXTERNAL VACUUM FOOD CONTAINERS

1. Start the machine
2. Place the hose connector over the extraction opening of the machine chamber of the machine

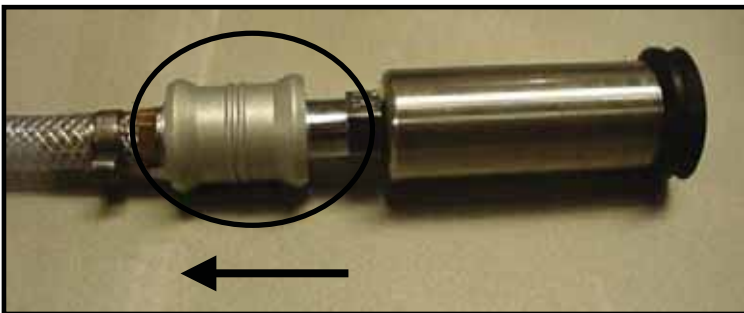

3. Check that the sliding valve on the vacuum applicator is on the side of the hose (closed position).



4. Press the conditioning key C appears in the display. Press the SELECTOR key until [E] (External vacuuming) appears on the display.

5. Place the vacuum applicator over the valve of the container and slide the sliding valve towards the lid to open the valve.



6. Press the + Key. The vacuum pump starts to run and the container is vacuumed.

7. When the vacuum meter reaches -1 then the container is fully vacuumed.



8. Press the - Key to stop the vacuum pump

9. The vacuum applicator can now be removed from the lid by sliding back the slider.

10. The container is now ready for cool storage.

11. If the machine needs to be used for normal applications then the hose can be removed from the extraction opening and the normal program mode can be selected by pushing twice the SELECTOR key

REMOVAL TOOLS FRONT PANEL

With every machine we ship-out we enclose two special tools to make it possible to remove the front panel. The tools slide in the slots at the bottom side of the front panel. Now lift it a little and pull it towards you.

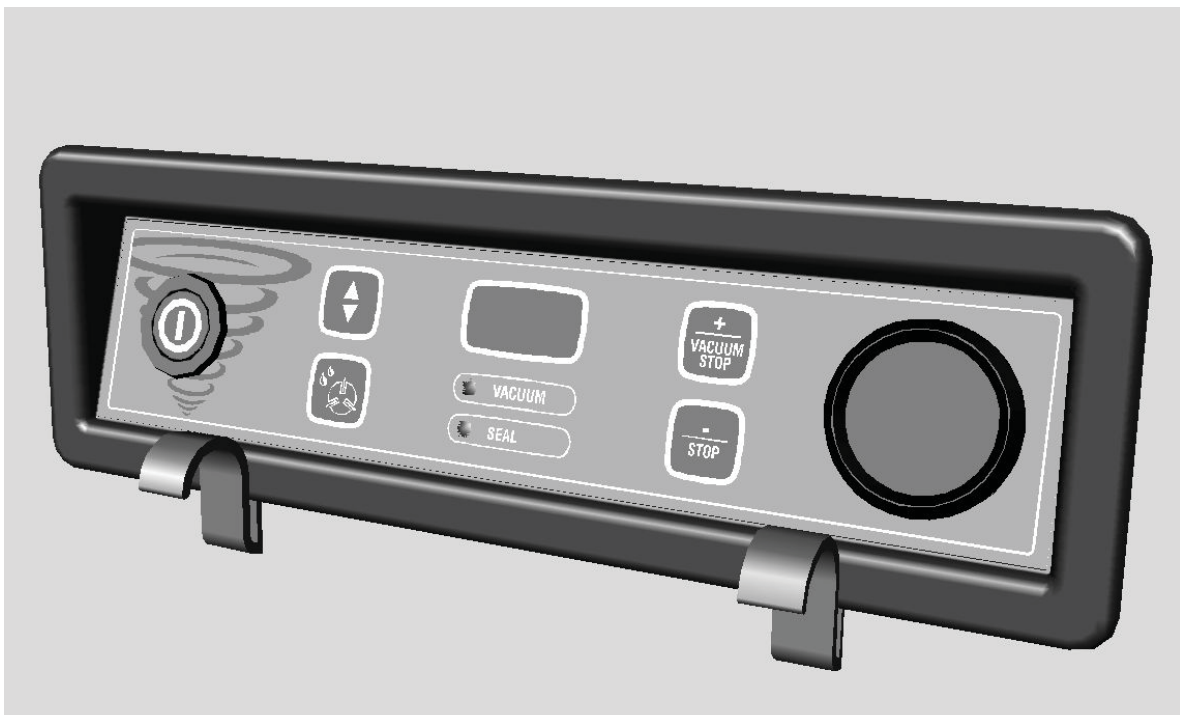

NATIONAL HEAD OFFICE

156 Swann Drive, Derrimut, VIC 3030

Phone: 03 8369 4600

Fax: 03 8369 4699

Email: sales@comcater.com.au

EQUIPMENT SALES

Phone: 1800 035 327

Fax: 1800 808 954

VIC/TAS SALES SHOWROOM & DEMONSTRATION KITCHEN

96-100 Tope Street, South Melbourne, VIC 3205

Phone: 03 8369 4600

Fax: 03 8699 1299

Email: sales@comcater.com.au

NSW/ACT SALES SHOWROOM & DEMONSTRATION KITCHEN

Unit 20/4 Avenue Of The Americas, Newington, NSW 2127

Phone: 02 9748 3000

Fax: 02 9648 4762

Email: nswsales@comcater.com.au

QLD/NT SALES SHOWROOM & DEMONSTRATION KITCHEN

1/62 Borthwick Avenue, Murarrie, QLD 4172

Phone: 07 3399 3122

Fax: 07 3399 5311

Email: qldsales@comcater.com.au

WA SALES

Unit 4 / 35 Westchester Road, Malaga, WA 6090

Phone: 08 9248 9290

Fax: 08 9248 1903

Email: wasales@comcater.com.au

SA SALES

Phone: 0409 340 015

Email: sasales@comcater.com.au

EQUIPMENT SERVICING (24/7)

Phone: 1800 810 161

Fax: 03 8369 4696

Email: service@comcater.com.au

EQUIPMENT SPARE PARTS

Phone: 1300 739 996

Fax: 03 8369 4696

Email: spares@comcater.com.au

TECHNICAL PHONE SUPPORT

Phone: 1300 309 262

Fax: 03 8369 4696

Email: technicalsupport@comcater.com.au

www.comcater.com.au