

# SLANT TOP INGREDIENT BINS



## MODEL IBS20

21 gallon (81 L)

## MODEL IBS27

27 gallon (102 L)

## MODEL IBS37

37 gallon (140 L)

### Slant Top Lid includes:

Stationary back piece and sliding front piece. These can be easily removed for complete cleaning. Made of virtually unbreakable Camwear® Polycarbonate. Replacement parts available for ordering.



Remove S-Hook and place in hole  
on front rim of the bin body.

S-Hook included to hang scoop in front for easy access. The following Camwear Polycarbonate scoops can be ordered separately:

SCP6CW	6 oz. (170 g)
SCP12CW	12 oz. (340 g)
SCP24CW	24 oz. (680 g)
SCP64CW	64 oz. (1814 g)

**CAMBRO**  
MANUFACTURING COMPANY

DURABILITY THAT MAKES A DIFFERENCE®

# CARE AND MAINTENANCE

## Casters

Whenever the unit has been washed or steam cleaned the following maintenance should be performed on the casters:

- Grease swivel raceway of caster using a lubricant such as: **Lubriplate No. 930-AA, Keystone #84EPLXT Multi-Purpose Grease**, or the equivalent. Moving "O" ring or seal with finger and apply grease using a needle nose adapter on grease gun, or a tube type applicator such as "Sta-Lube" moly-graph assembly lube. (These can be obtained at most auto parts stores.)
- No lubrication is needed on casters with a bearing hub wheel. On casters using a nylon bushing at the hub, use a light oil such as **WD-40**.
- When done, check caster movement both in wheel spin and swivel rotation for any damage before returning to service.

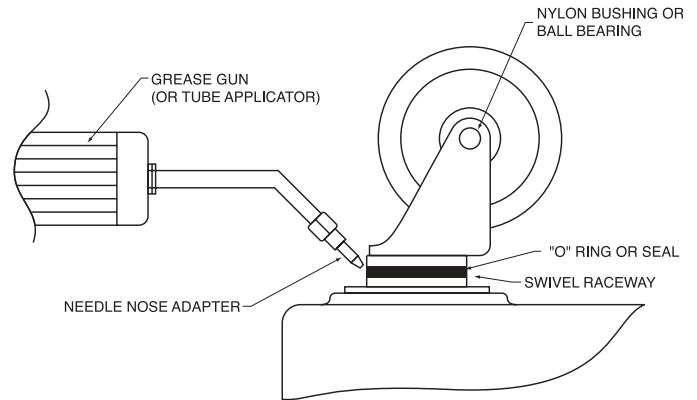

## Camwear® (Polycarbonate) Cleaning Recommendation

To ensure that you get the longest possible service from your Slant Top Ingredient Bin Lids, we recommend the following cleaning products, *when used as directed by the supplier*. Please contact the supplier directly for questions on usage.

Cleaning Product	Supplier
Solid Supra, Solid Power Guardian Acclaim Solid Guardian Plus Solid Super Impact Solid Insure	<b>Ecolab, Inc.</b> 370 Wabasha St. St. Paul, MN 55102 Tel: (800) 352-5326 www.ecolab.com
Diverpak Eclipse H2 Liqua-Safe	<b>Johnson Diversey</b> 8310 16th Street P.O. Box 902 Surtevant, WI 53177-0902 Tel: (262) 631-4001 www.johnsondiversey.com
Acclean HC 500 Poly-Brite	<b>Ecolab, Inc./Food &amp; Beverage Div.</b> 370 Wabasha St. St. Paul, MI 55102 Tel: (612) 293-2165 www.ecolab.com
Glow MB-1 Lustre NC-25 Lustre Plus	<b>Wesmar Company, Inc.</b> 1451 NW 46th St. Seattle, WA 98107 Tel: (800) 824-4917 or (206) 783-5344 Fax: (206) 782-4291
Liqui-Ware 1 Liqui-Ware MC D-Flex Sur-Met	<b>Anderson Chemical Company</b> 325 South Davis Litchfield, MN 55355-1041 Tel: (800) 366-2477 or (320) 693-2477 Fax: (320) 693-8238 www.andersonchemco.com

Rinse Aid	Supplier
Solid Rinse Dry Solid Brilliance Jet Dry Rinse Dry	<b>Ecolab, Inc.</b> 370 Wabasha St. St. Paul, MN 55102 Tel: (800) 352-5326 www.ecolab.com
Destainer	Supplier
NuWare	<b>Johnson Diversey</b> 8310 16th Street P.O. Box 902 Surtevant, WI 53177-0902 Tel: (262) 631-4001 www.johnsondiversey.com
Cleaning Pad	Supplier
Scotch-Brite White #9030 Scotch-Brite Blue #2001	<b>3M</b> 3M Center Building, 223-6S-03 St. Paul, MN 55144-1000 Tel: (800) 698-4595 Fax: (800) 447-0408 www.mmm.com