

Electric, self contained, tilting twin kettle, 23 litre per side capacity, 2/3 steam jacketed. All exterior surfaces are stainless steel. Simple & reliable solid state controls for accurate temperature control.

STANDARD FEATURES

- Manual tilting, balanced design
- Space saving design through shared, centre console
- Self-contained
- IPX6 Rated water resistant controls, splash-proof construction
- Large pouring lip for high capacity and chunky products
- 50 psi steam jacket rating for higher cooking temperatures
- Solid state water level control
- Splash proof element cover with a double gasket seal
- Welded-in heating elements
- Steam jacket filled with treated water, venting and/or refilling is not required
- Reinforced rolled rim design prevents damage to kettle rim, eliminates "bar rim designs"
- Easily cleaned: kettle and all exterior surfaces are of type 304 stainless steel with an #4 finish
- Operating temperature range from 63°C - 127°C
- Rear mounted easy access pressure gauge and pressure relief valve to prevent tampering.
- Self locking marine type tilting mechanism prevents accidental spills. Balanced design makes it easy to tilt
- 316 Stainless Steel Kettle Liner for high acid products (316-G)

ACCESSORIES

- Stainless Steel Equipment Stand with Drain Drawer 450mm height. (ST55)
- Optional Splash Guard for equipment stand (2 x SG-28)
- Common Hot and Cold Water Faucet with Swing Spout. (DPK19)
- Kettle Markings (KML x2 - factory fitted)
- Food Strainers (FS6 x2)
- Cooking Baskets (BS6 x2)
- Measuring Strips (MS6 x2)
- Lift Off Covers (CL6 x2)

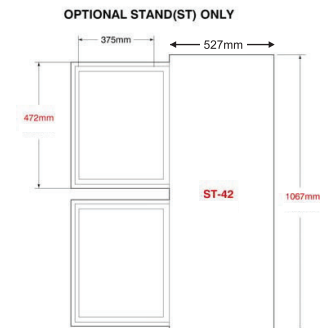
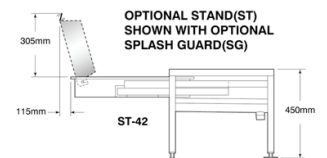
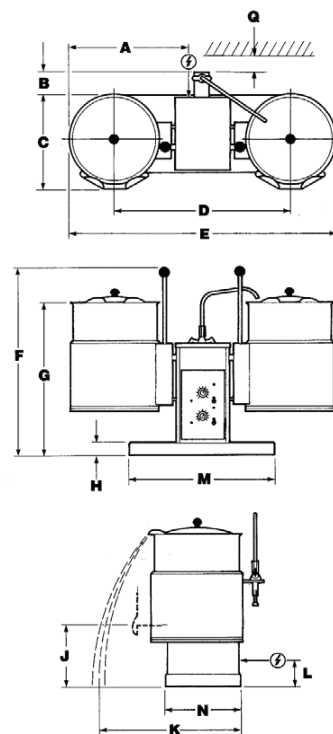

TECHNICAL DATA

Power Supply: 3NAC 415V 50Hz, 20.9 amp
(Cable & Plug not included)

Total Output: 15kW

Capacities (per kettle):
(in 115 gram servings, other sizes may be calculated)
6 gallons / 23 litres - 192 servings

SHIPPING DATA

Shipping Weight: 100 kg
Shipping Dimensions: 711W x 1372D x 991H mm

SPECIFICATIONS ARE SUBJECT TO CHANGE WITHOUT NOTICE.

BASE MOUNTING DIAGRAMS (VIEW FROM BOTTOM OF BASE)

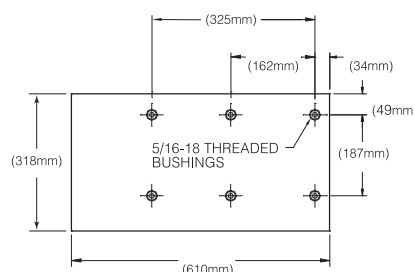

WATER

3/8" O.D. copper tube or
1/2" N.P.T. pipe.

When ordered with
optional faucet.

CLEARANCE

RIGHT = 0"
LEFT = 0"
REAR = See "Q" on
chart above.

DIMENSIONS (mm)

Lt.	A	B	C	D	E	F	G	H	J	K	L	M	N	Q
23	525	110	425	743	1124	730	580	38	180	675	350	610	320	70