



# trueheat

GAS COOKING EQUIPMENT



INSTALLATION & OPERATION MANUAL

**RCT**  
**RCR**  
Open Burner,  
Griddle & Oven Range

# CONGRATULATIONS!



Thank you for choosing Trueheat.

This product has been specifically designed by Comcater to meet a wide range of applications and represents the best quality and highest value equipment.

Please read the Instruction Manual carefully to ensure the safe and reliable operation and performance of your equipment.

Should you require service, you will be supported by Comcater's trained and qualified service network.

## COMCATER AUSTRALIA

[www.comcater.com.au](http://www.comcater.com.au)

### National Head Office

156 Swann Drive, Derrimut, VIC 3030

Phone: 03 8369 4600

Fax: 03 8369 4699

Email: [sales@comcater.com.au](mailto:sales@comcater.com.au)

### Technical Services Group

Phone: 1800 810 161

Fax: 03 8369 4696

### Email:

**Equipment Servicing (24/7)**

[service@comcater.com.au](mailto:service@comcater.com.au)

**Equipment Spare Parts**

[spares@comcater.com.au](mailto:spares@comcater.com.au)

**Technical Support**

[techsupport@comcater.com.au](mailto:techsupport@comcater.com.au)

## Comcater QR Codes



Comcater Website



Log a Service Call



Online Spare Parts Store

Reproduction or copying of any part of this manual by any means whatsoever is strictly forbidden unless authorised in writing by Comcater. Comcater reserves the right to change design and specifications without prior notice. © Copyright Comcater Pty Ltd, August 2017.

# TABLE OF CONTENTS



<b>INTRODUCTION</b>	
Warranty.....	4
Date Plate Location .....	4
<b>WARNINGS</b> .....	5
<b>GENERAL INFORMATION</b> .....	6
<b>SPECIFICATIONS</b>	
Dimensions, Weight & Installation Drawings.....	7
Accessories & Optional Accessories .....	7
Gas Configuration .....	8
Gas Consumption by model .....	9
<b>INSTALLATION</b>	
Gas Connection .....	10
Installation Clearances .....	11
Levelling .....	11
<b>COMMISSIONING / BURNER ADJUSTMENT</b>	
Leak Test .....	12
Test Point Pressure .....	12
Pilot Adjustment .....	12
Target Adjustment .....	12
<b>GAS CONVERSION</b>	
Gas Conversion Kits.....	13
<b>OPERATION</b>	
First Time Use .....	14
Daily Operation .....	14
Lighting instructions.....	14
<b>MAINTENANCE</b>	
Griddle Seasoning and Maintenance .....	15
Daily Cleaning, Stainless Steel, Enamel coated surfaces .....	16
Recommended Service Plan .....	17
<b>TROUBLESHOOTING</b>	
Burner will not light .....	18
Pilot will not light.....	18

# INTRODUCTION



## GENERAL

The Trueheat RC Series is designed for commercial catering purposes only and incorporates a wide range of design features. It is designed to deliver high-end performance to fulfill the busy demands within a commercial kitchen. It is available in various appliances and configurations including: Ranges with open burners, griddles with oven or as Counter-Top unit.

Broilers, salamanders, pasta cookers and deep fryers.

This versatility will satisfy a wide range of customer needs.

## WARRANTY

12 months replacement of parts including labour, for goods found to be faulty due to defective materials, manufacture and/or workmanship. This warranty is void if installation, operation and/or maintenance of the equipment are not in accordance with manufacturer's instructions and recommendations.

Unauthorised modifications to the equipment will void the warranty and product certification.

All warranty work will be undertaken in normal working hours from Monday – Friday 8:00am to 4:00pm

Warranty does not extend to:

Damages caused in shipment

Damage as a result of incorrect installation

Damage as a result of incorrect operation

Damages caused by Unauthorised service and use of non-original parts

Gas supply issues to the equipment

Calibration of thermostats after 90 days

Failure resulting from improper maintenance

Failure as a result of tampering with, removal of, or changing any pre-set control or safety device

After hours Service - **Penalty rates apply for afterhours service.**

Conditions as defined in Comcater terms and condition of sale, a copy of Comcater's terms and conditions of sale can be found at [www.comcater.com.au/terms](http://www.comcater.com.au/terms)

For all warranty work, authorized service, genuine and authorized spare parts, please contact Comcater Service 1800 810 161.

Please ensure you quote the Model and Serial Number of the unit.





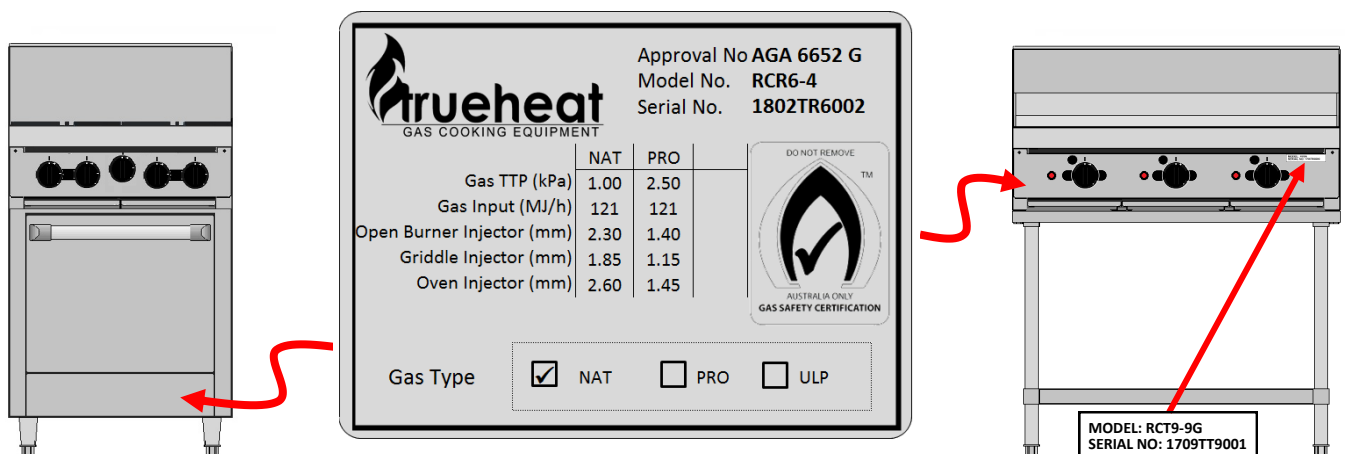



The Model and Serial Number of the unit is recorded on the sales invoice, and also shown on the top right side of the front control panel on Counter-Top models and on the data plate.

The data plate is located behind the front control panel.



**NOTE: Data Plate is located behind the control panel on Counter-Top models, and behind the kicker plate on Oven Range Models.**

# WARNINGS

	<p><b>IMPROPER INSTALLATION, ADJUSTMENT, ALTERATION, SERVICE OR MAINTENANCE CAN CAUSE INJURY OR DEATH. THE INSTRUCTION MANUAL MUST BE READ CAREFULLY BEFORE INSTALLING, OPERATING OR SERVICING THIS EQUIPMENT.</b></p>
	<p><b>TO BE INSTALLED ONLY BY AN AUTHORISED PERSON IN ACCORDANCE WITH AS 5601, LOCAL AUTHORITY, GAS, ELECTRICITY, ANY APPLICABLE STATUTORY REGULATIONS AND MANUFACTURER REQUIREMENTS.</b></p>
	<p><b>THIS EQUIPMENT IS DESIGNED FOR COMMERCIAL CATERING PURPOSES AND WILL GENERATE SIGNIFICANT HEAT. HOT SURFACES WILL CAUSE BURNS. A HAZARD AND RISK ASSESSMENT MUST BE UNDERTAKEN BY OWNERS AND ALL OPERATORS MADE AWARE OF THESE.</b></p>
	<p><b>DO NOT STORE OR USE FLAMMABLE LIQUIDS NEAR THIS APPLIANCE.</b></p>
	<p><b>DO NOT SPRAY AEROSOLS NEAR THIS APPLIANCE WHILE IT IS IN OPERATION.</b></p>
	<p><b>INSTALLATION CLEARANCES AS SPECIFIED MUST BE OBSERVED.</b></p>
	<p><b>IF YOU SMELL GAS, TURN THE UNIT OFF AND THE MAIN GAS SUPPLY VALVE TO THE UNIT. CONTACT YOUR GAS SUPPLIER OR AN AUTHORISED PERSON.</b></p>
	<p><b>BEFORE TURNING ON THE MAIN GAS SUPPLY, CHECK THE UNIT TO BE CERTAIN THAT ALL THE VALVES ARE IN THE “OFF” POSITION.</b></p>

# GENERAL INFORMATION



## INSPECTION

Please inspect the unit on receipt. If the unit is damaged, contact the carrier immediately and file a damage claim with them. Save all packing materials when filing a claim. Freight damage claims are the responsibility of the purchaser and are not covered under warranty.

## OPERATOR MANUAL

This manual contains important information for your safety and the installation, operation, maintenance and service of this equipment. Please read the manual carefully and ensure all operators of the equipment are aware of the contents and safety requirements. You must also assess all hazards and risks associated with the operation of the equipment in your environment and advise all operators of these.

## INSTALLATION

This equipment must be installed by an authorized person in accordance with AS 5601, local authority, gas, electricity, any applicable statutory regulations and manufacturer requirements.

## GAS CONNECTION

The appliance must be connected by an authorized person to the gas type specified on the unit. The gas type is shown adjacent to the rear gas connection point and on the data plate. Connect to and use only the correct type of gas.

## GAS PRESSURE

The authorized person installing this equipment must ensure that the gas operating pressure is the same as shown on the rating plate and that there is sufficient gas volume for the appliance to operator correctly.

## COMMISSIONING

The authorized person installing this equipment must commission the equipment in accordance with AS 5601 - gas leakage, operational checking, adjustments and instructing the owner on use of the equipment are prescribed requirements.







# SPECIFICATIONS

## DIMENSIONS, WEIGHT & INSTALLATION DRAWINGS, OPTIONAL ACCESSORIES

The following tables and drawings provide all dimension, weight and optional accessories.



DESCRIPTION	RCT3-2	RCT-3G	RCT6-4	RCT6-2-3G	RCT6-6G	RCT9-6	RCT9-2-6G	RCT9-4-3G	RCT9-9G	RCR6-4	RCR6-2-3G	RCR6-6G	RCR9-6	RCR9-2-6G	RCR9-4-3G	RCR9-9G
Width (mm)	300	300	600	600	600	900	900	900	900	600	600	600	900	900	900	900
Depth (mm)	803	803	803	803	803	803	803	803	803	803	803	803	803	803	803	803
Height (mm)	445	445	445	445	445	445	445	445	445	1135	1135	1135	1135	1135	1135	1135
Height on stand (mm)	1135	1135	1135	1135	1135	1135	1135	1135	1135	N/A	N/A	N/A	N/A	N/A	N/A	N/A

## OPTIONAL ACCESSORIES

IMAGE	PART NO.	DESCRIPTION	Qty
	RCSTD3	300mm Stand complete with shelf, Suits RCT3 Counter-Top models	1
	RCSTD6	600mm Stand complete with shelf, Suits RCT6 Counter-Top models	1
	RCSTD9	900mm Stand complete with shelf, Suits RCT9 Counter-Top models	1
	GF-CSTRB	Front Castor Swivel with brake suits RCR models only	2
	GF-CSTR	Rear Castor without brake suits RCR models only	2
	B05002	Adjustable legs for RCT Counter-Top mounting only	4
	432018-900HK	900mm 3/4" flexible gas hose with quick connect fittings & restraint	1
	432018-1200HK	1200mm 3/4" flexible gas hose with quick connect fittings & restraint	

# SPECIFICATIONS (cont'd)

## GAS CONFIGURATION

	<b>TO BE COMPLETED BY AN AUTHORISED PERSON.</b>
	<b>ONLY CONNECT THE APPLIANCE TO THE GAS TYPE IT HAS BEEN CONFIGURED FOR. THE GAS TYPE IS SPECIFIED ON THE DATA PLATE AND AT THE REAR OF THE APPLIANCE.</b>

	NATURAL GAS	PROPANE GAS
<b>Minimum Gas Inlet Pressure</b>	1.13 kPa	2.75 kPa
<b>Test Point Pressure</b>	1.00 kPa	2.50 kPa





Burner	Description	NATURAL GAS	PROPANE GAS
Open Burner	Gas Consumption	24 MJ/h	24 MJ/h
	Main Injector	2.30mm	1.40mm
	Pilot Orifice (marking)	Adjustable Orifice (20)	Adjustable Orifice (20)
	Low-flame Setting	1 ½ turns from fully in	¾ turn from fully in
Griddle Burner	Gas Consumption	16.5 MJ/h	16.5 MJ/h
	Main Injector	1.85mm	1.15mm
	Pilot Orifice (marking)	Adjustable Orifice (35)	Adjustable Orifice (35)
	Low-flame Setting	1 ½ turns from fully in	¾ turn from fully in
600mm Oven Burner	Gas Consumption	25 MJ/h	25 MJ/h
	Main Injector	2.60mm	1.45mm
	Pilot Orifice (marking)	Adjustable Orifice (35)	Adjustable Orifice (35)
	Low-flame Setting	1/4 turn out from fully in	1/8 turn out from fully in
900mm Oven Burner	Gas Consumption	36 MJ/h	33 MJ/h
	Main Injector	3.26mm	1.70mm
	Pilot Orifice (marking)	Adjustable Orifice (35)	Adjustable Orifice (35)
	Low-flame Setting	1/4 turn out from fully in	1/8 turn out from fully in

### NOTES:

1. When checking gas pressure, ensure that all other equipment on the same line is turned "ON".
2. Values shown are those measured at the manifold pressure test point

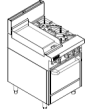
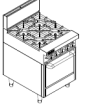

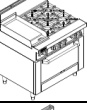
## NOMINAL GAS CONSUMPTION

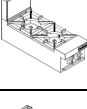
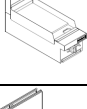
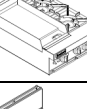
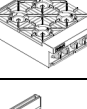
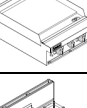
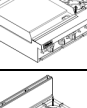
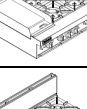
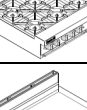
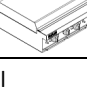
MODEL	IMAGE	OPEN BURNER	GRIDDLE BURNER	OVEN	NATURAL GAS	PROPANE GAS
RCR6-2-3G		2	1	600mm	89.5 MJ/h	89.5 MJ/h
RCR6-4		4	-	600mm	121 MJ/h	121 MJ/h
RCR6-6G		-	2	600mm	58 MJ/h	58 MJ/h
RCR9-2-6G		2	2	900mm	117 MJ/h	114 MJ/h
RCR9-4-3G		4	1	900mm	148.5 MJ/h	145.5 MJ/h
RCR9-6		6	-	900mm	180 MJ/h	177 MJ/h
RCR9-9G		-	3	900mm	85.5 MJ/h	82.5 MJ/h
RCT3-2		2	-	-	48 MJ/h	48 MJ/h
RCT3-3G		-	1	-	16.5 MJ/h	16.5 MJ/h
RCT6-2-3G		2	1	-	64.5 MJ/h	64.5 MJ/h
RCT6-4		4	-	-	96 MJ/h	96 MJ/h
RCT6-6G		-	2	-	33 MJ/h	33 MJ/h
RCT9-2-6G		2	2	-	81 MJ/h	81 MJ/h
RCT9-4-3G		4	1	-	112.5 MJ/h	112.5 MJ/h
RCT9-6		6	-	-	144 MJ/h	144 MJ/h
RCT9-9G		-	3	-	49.5 MJ/h	49.5 MJ/h

# INSTALLATION



**THIS EQUIPMENT MUST BE INSTALLED BY AN AUTHORIZED PERSON IN ACCORDANCE WITH AS/NZS 5601, LOCAL AUTHORITY, GAS, ELECTRICITY, ANY APPLICABLE STATUTORY REGULATIONS AND MANUFACTURER REQUIREMENTS.**

**Note:** Installation is the responsibility of the owner.

## GAS INLET CONNECTION

3/4" BSP Female.

## GAS CONNECTION POINT

The gas connection point is located at the rear of the appliance within the void below the flue as shown in the diagram on the right. The location is the same for Counter-Top and Oven Range models.

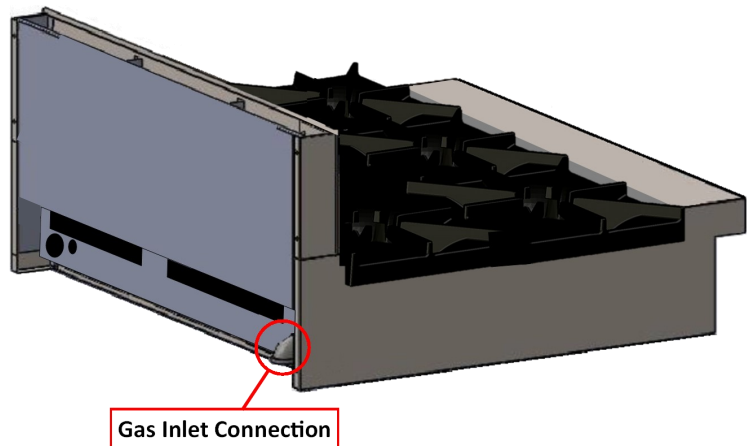

## GAS CONNECTION

The appliance must be connected by an authorised person to the gas type specified on the unit. The gas type is shown adjacent to the rear gas connection point and on the data plate. Only connect to and use the specified gas type that the appliance has been set for.

Do not remove or modify any of the gas piping within the appliance. The gas connection must be made at the connection point provided.

Removal or modification of the gas piping within the appliance will void the gas certification & manufacturer's warranty. This may also affect the customer's insurance policy.

The authorised person installing this equipment must comply with AS 5601 requirements. Prescribed requirements include, commission the equipment, gas leakage testing, operational checking and adjustments.

All units are tested and adjusted at the factory; however, burners and pilots must be checked at the installed location and adjusted if necessary.

## FLUE COVER INSTALLATION

For transport purposes the flue cover for all RCT & RCR models will arrive uninstalled, resting flat across the trivets or griddle plate. To install, position the flue above the void at the rear of the unit with the stainless steel side facing the forward, align the two guides with the void of the unit and lower into the void. Press down firmly until the flue cover is in place.

### INSTALLATION ON STAND

The Counter-Top models can be installed on a stand. Counter-Top models are positively located on the stand by inserting four bolts from the underside of the stand into nutserts in the appliance.

**WARNING:** Ensure the appliance is correctly fastened to the stand.

Adjustable feet are included on the leg stands and allow the unit to be levelled to the floor in the installed location. Stands with Castors are also available option.

### INSTALLATION ON COUNTER-TOP

Open Burner or Griddle Counter-Top models can be installed on a non-combustible Counter-Top or refrigerated cabinet with optional 100mm adjustable Counter-Top legs. It is recommended that the appliance is secured to the counter to prevent unintended movement.

### INSTALLATION CLEARANCES

The MINIMUM clearance from combustable surfaces is 150mm rear and 150mm on either side. See diagram below.

**NOTE:** Ensure adequate clearance is provided for service & maintenance.

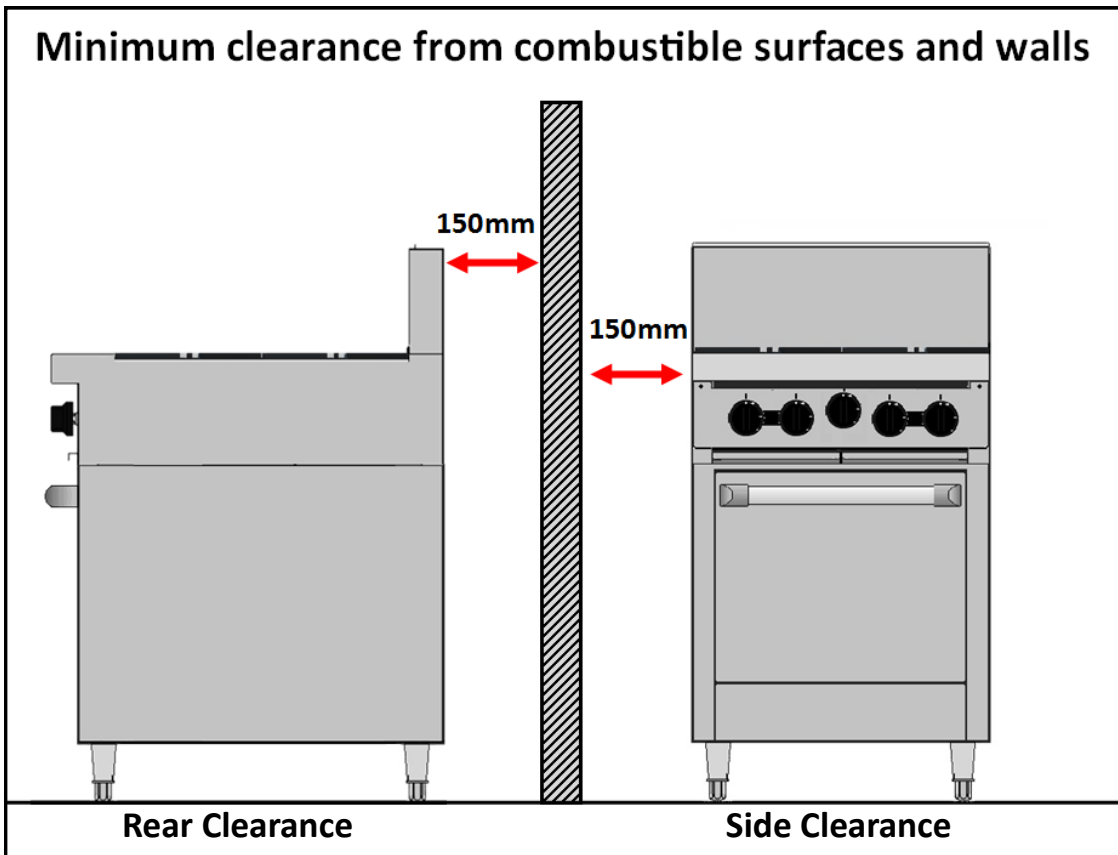
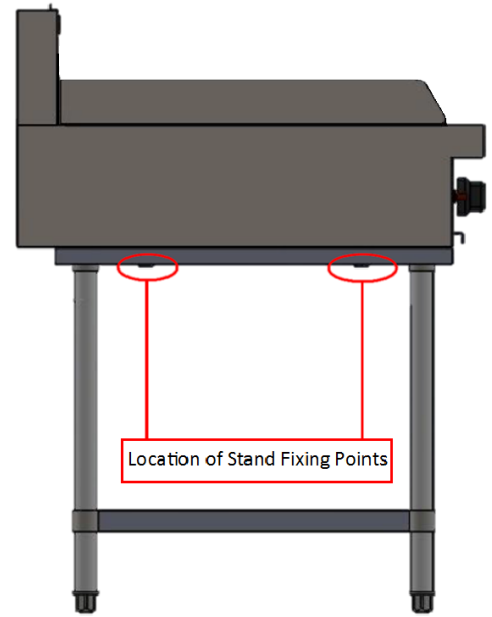

### LEVELLING

To adjust the legs to level the unit to the floor and/or to slightly adjust the height of the unit, raise the front of the unit and adjust the legs (ensure safe work practices). Similarly, raise the back and adjust the legs.

**NOTE:** Unleveled Oven Ranges will affect door alignment and may cause heat to escape around door.

**DO NOT LAY THE UNIT ON ITS BACK. ENSURE THE UNIT IS CORRECTLY LEVELLED.**

# COMMISSIONING

## LEAK TEST

- Ensure that the valve is in the OFF position.
- Turn on the main gas supply valve.
- Light all pilots.
- Leak test the valve and fittings using approved methods.
- Correct any leaks as required and re-check.
- Shut off the gas valve



**WARNING: IF YOU ARE NOT COMPETENT IN PERFORMING ANY SERVICE TASK OR REQUIRE ASSISTANCE, PLEASE CONTACT: COMCATER SERVICE**

## TEST POINT PRESSURE

The test point is located on the gas manifold behind the control panel. The test point pressure is shown on the appliance data plate and in the Gas Configuration Table.

## LOW FLAME ADJUSTMENT

The low flame adjustment screw is located on each gas valve adjacent to the control shaft. Low flame adjustment setting is shown in the Gas Configuration Table on Page 8.

## PRIMARY AIR SETTING

The Primary Aeration shutter setting is gas type specific. When converting between gas types ensure that the correct Primary Aeration setting and interrupter screw are used per the diagram below.

## GAS CONTROLS—BEHIND CONTROL PANEL

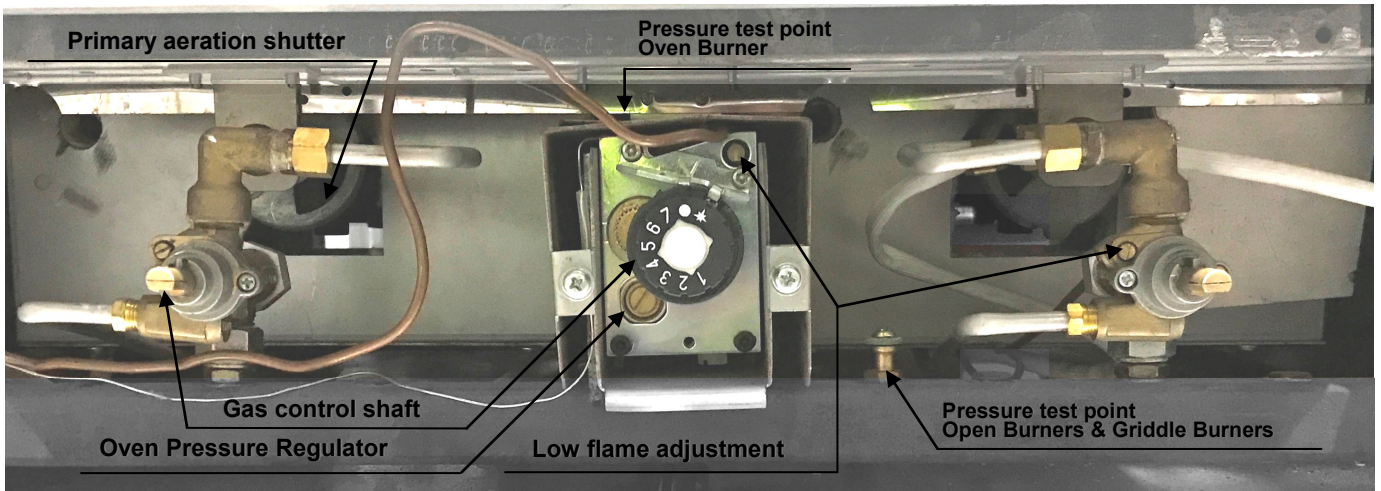
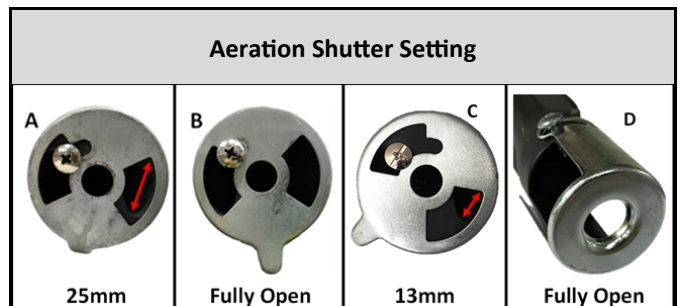





Table 1: Primary Air Setting		Dwg Ref	Setting
600mm & 900mm Oven Burner	Natural Gas	A	25mm
	Propane Gas	B	Fully Open
Griddle Burner	Natural Gas	A	25mm
	Propane Gas	C	13mm
Open Burner	Both Natural Gas & Propane Gas	D	Fully Open



# GAS CONVERSIONS







	<b>ONLY TO BE COMPLETED BY AN AUTHORISED PERSON</b>
	<b>ENSURE GAS IS ISOLATED WHILST PERFORMING CONVERSION WORK.</b>
	<b>PERFORM A LEAK TEST BEFORE IGNITING AND CALIBRATING BURNER AND PILOT ADJUSTEMENTS.</b>

The RCT & RCR Series of Open burners, Griddles & Ovens can be configured to operate on either Natural Gas or Propane Gas. If a Gas Conversion is required, Gas conversion kits are available through Comcater Spare Parts for either gas type. Detailed conversion Instructions are provided with the Gas Conversion kits.

## RCT & RCR GAS CONVERSION KIT PART NUMBERS

Model	Natural Gas	Propane Gas
RCT3-2	THSP-RCT3-2-GCKIT-NG	THSP-RCT3-2-GCKIT-LP
RCT3-3G	THSP-RCT3-3G-GCKIT-NG	THSP-RCT3-3G-GCKIT-LP
RCT6-4	THSP-RCT6-4-GCKIT-NG	THSP-RCT6-4-GCKIT-LP
RCT6-2-3G	THSP-RCT6-2-3G-GCKIT-NG	THSP-RCT6-2-3G-GCKIT-LP
RCT6-6G	THSP-RCB9-GCKIT-NG	THSP-RCB9-GCKIT-LP
RCT9-6	THSP-RCT9-6-GCKIT-NG	THSP-RCT9-6-GCKIT-LP
RCT9-4-3G	THSP-RCT9-4-3G-GCKIT-NG	THSP-RCT9-4-3G-GCKIT-LP
RCT9-2-6G	THSP-RCT9-2-6G-GCKIT-NG	THSP-RCT9-2-6G-GCKIT-LP
RCT9-9G	THSP-RCT9-9G-GCKIT-NG	THSP-RCT9-9G-GCKIT-LP
RCR6-4	THSP-RCR6-4-GCKIT-NG	THSP-RCR6-4-GCKIT-LP
RCR6-2-3G	THSP-RCR6-2-3G-GCKIT-NG	THSP-RCR6-2-3G-GCKIT-LP
RCR6-6G	THSP-RCB9-GCKIT-NG	THSP-RCB9-GCKIT-LP
RCR9-6	THSP-RCR9-6-GCKIT-NG	THSP-RCR9-6-GCKIT-LP
RCR9-4-3G	THSP-RCR9-4-3G-GCKIT-NG	THSP-RCR9-4-3G-GCKIT-LP
RCR9-2-6G	THSP-RCR9-2-6G-GCKIT-NG	THSP-RCR9-2-6G-GCKIT-LP
RCR9-9G	THSP-RCR9-9G-GCKIT-NG	THSP-RCR9-9G-GCKIT-LP

## CONTENTS

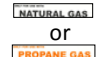
Image	Description
	RCT/RCR GAS CONVERSION INSTRUCTIONS
	OPEN BURNER INJECTORS
	GRIDDLE BURNER INJECTORS
	600MM OVEN BURNER INJECTOR
	900MM OVEN BURNER INJECTOR
	SPRING FOR GAS REGULATOR
	GAS TYPE LABEL FOR REAR OF APPLIANCE
	GAS TYPE LABEL FOR DATA PLATE

**Note: Component quantities vary per model.**

To arrange a Gas Conversion contact Comcater Service 1800 810 161

# OPERATION

## FIRST TIME USE

Before lighting the equipment for the first time, ensure that all package materials including the stainless steel protective film and moisture absorption packs have all been removed from the drip trays before lighting.

Use warm soapy water and a cloth to wipe down and remove any dust or metal filings that may have settled during manufacturing.

## CORRECT ASSEMBLY

Before first time use ensure that all burners, trivets & griddle plates have not moved during transport. Incorrect alignment may affect the operation of the equipment.

Note: Always ensure that the front and rear splash guards are fitted to griddle plates before cooking. The splash guards prevent food matter from seeping beneath the griddle plate.

## LIGHTING INSTRUCTIONS

1. Turn the Control knob from position "off" ● to "Pilot" ★.
2. Depress control knob and hold it down and light pilot immediately with "piezo ignitor".  
Note: The pilot can be seen through the "pilot viewing hole".
3. Once the pilot has lit, continue to hold in the control knob for 10 seconds, before slowly releasing. (Verify that the pilot is still lit once the control knob has been released, if not repeat step 3 & 4).
4. Turn gas control knob to the "Hi-flame" 🔥 position or to the desired set point temperature if operating an Oven. The burner will then ignite.
5. If the pilot becomes extinguished, repeat the above procedure.

## SHUTDOWN INSTRUCTIONS

1. Turn the gas control knob to the "off" ● position.
2. Allow the equipment to cool down before cleaning.

## DIAGRAM - OPERATOR CONTROLS

### Open Burners & Griddle Controls

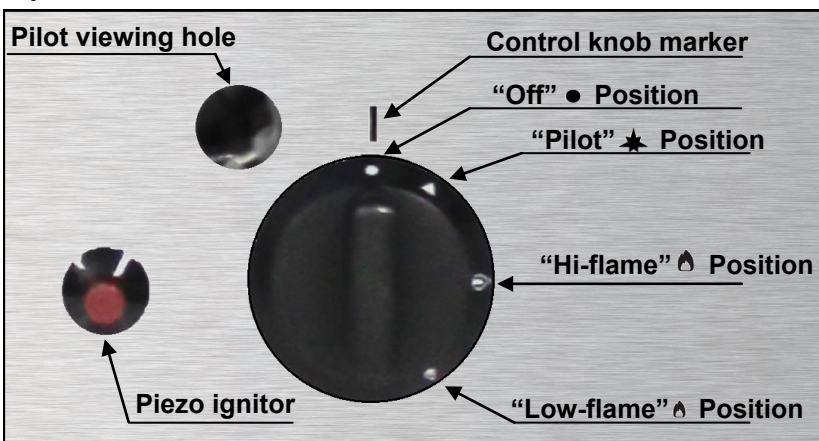

### 600mm & 900mm Oven Controls

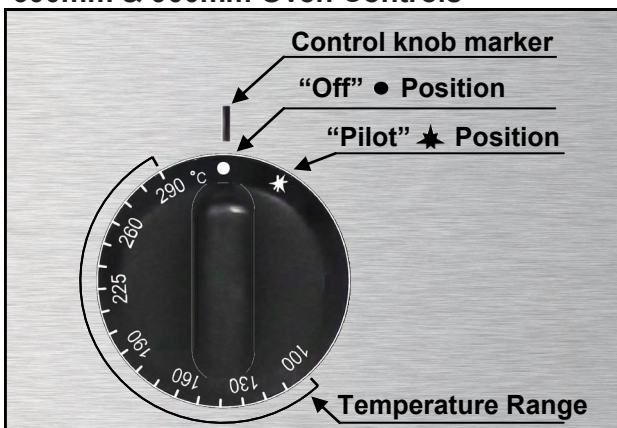

### Beneath Oven Kicker Plate

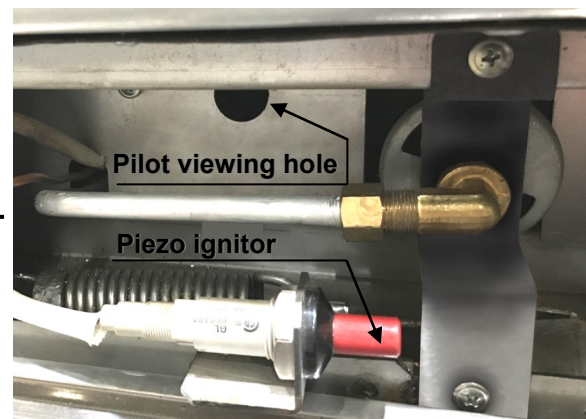



**USE ONLY SUITABLE CHEMICALS AND OBSERVE ALL MANUFACTURER SAFETY REQUIREMENTS FOR SAFE HANDLING AND USE.**

## SEASONING THE GRILL

**NOTE:** The grill surface has protective coating applied at manufacture. Remove this by washing with hot water and a mild detergent until clean.

Season the grill by applying a thin coat of cooking oil with a cloth to the entire grill surface. Remove any excess oil with a cloth.

Light the grill burner(s) and set at the lowest level (LEVEL 2). Operate the grill for about 20 minutes and then wipe away the oil. Repeat this procedure three times.

**IMPORTANT: Only use low heat (LEVEL 2) when seasoning the grill.**

**NOTE:** The grill surface will discolour from heat. Discolouring will not affect the grill surface function and does not render the grill surface defective.

The grill surface should be cleaned with hot water and detergent.

Normally, if maintained properly, the grill will not need to be seasoned again. If, however, the grill has been overheated and product sticks to the grill surface, it may be necessary to season the grill again.

Carbon and grease will affect the cooking performance and should be removed as follows:

**After each use**, clean the grill thoroughly with a sharp grill scraper and wipe off any excess debris.

Remove and clean front and rear splash guards, dry and refit before next use.

**NOTE:** Empty the grease drawer as necessary and clean.

**Weekly**, clean the grill surface thoroughly with a grill pad while the surface is still warm (not hot).

After cleaning, ensure any detergent/chemical is thoroughly removed. The grill surface should be covered with a thin film of cooking oil to prevent rusting.

**Note:** The grill plate is made of steel and can be easily scored or dented by careless use of scrapers and spatulas.

# MAINTENANCE



## CLEANING STAINLESS STEEL

Regularly wipe the surface with hot water and detergent. Rinse the washed area with a wet sponge and clean water and wipe the area dry to prevent streaking. Follow this process and wash a small area at a time to prevent chemical residue and streaking.

Stainless steel may discolour if overheated. These stains can usually be removed using an appropriate powder/paste. To scrape off heavy deposits of grease and oil, use only wood or plastic tools as necessary.

**Note:** Never use steel wool to clean stainless steel.

**Note:** Damage may occur if chemicals not suitable for stainless steel are used.

## OVEN INTERIOR (Enamel)

**Note:** Remove all oven racks and guides and clean these separately with a suitable detergent and warm water.

The enamelled oven interior surface should be cleaned regularly with a suitable oven cleaner.

## OPEN TOP BURNERS



**Note:** Spillage is the major cause of problems to the performance of open top and pilot burners. Spillage can block gas ports, which then causes burners to operate inefficiently or, in bad cases, not at all. Clean any spillages as they occur.

**Note:** The burner caps are enamelled – do not use abrasive cleaners.

To clean the burners, remove the burner cap and clean with a suitable detergent and warm water. If the burner ports are blocked, clean these with a stiff brush. Place the burner cap back on the burner, ignite and check that the flame is even and comes from all ports (this dries the burner cap).



# MAINTENANCE

	<b>FOR YOUR SAFETY, ALL SERVICE WORK MUST BE CARRIED OUT BY AN AUTHORISED PERSON AND USE ONLY ORIGINAL SUPPLIED AND SPECIFIED PARTS.</b>
	<b>TEST ALL FITTINGS, PIPES AND PIPE CONNECTIONS FOR LEAKS IN ACCORDANCE WITH APPROVED GAS LEAK TEST PROCESSES AND METHODS. DO NOT USE A FLAME.</b>

## RECOMMENDED SERVICE PLAN

It is recommended that your appliance be serviced by an authorised person every 12 months. This period is for guidance purpose only and may vary based on usage of the equipment and operator care.

Prescribed service tasks include:

- Functional test of all components, clean and adjusted as necessary
- Inspect and clean all gas valves and lubricate with an industry approved lubricant
- Inspect all gas piping
- Check and adjust specified gas pressures
- Leak test
- Full operation, performance and safety test

For all technical queries, please contact Comcater's Technical Support Team.

### Technical Phone Support

Phone: 1800 810 161

Email: [techsupport@comcater.com.au](mailto:techsupport@comcater.com.au)

# TROUBLESHOOTING

Problem	Probable Causes	Corrective Action
Burner will not light	Pilot is not lit	Light the pilot as per instructions shown on the inside of the door or on Page 14 of this manual
	Gas Control is set to "Pilot" ★	Once a pilot has been established, ensure that the gas control dial is set to "Hi-Flame" 🔥 for open burners & griddle burners or the desired set point temperature for ovens.
	No gas supplied to unit	Verify that the gas line is connected, ensure all manual or automatic shutoff valves are open, including emergency gas shut-offs. Note: some exhaust systems have a gas supply interlock fitted, that will disrupted gas supply to the equipment if the exhaust hood isn't operating.
Pilot will not light	Pilot injector has a blockage or Gas pressure is too low	When the pilot is lit, the flame is too small to activate the thermocouple and hold the pilot on.  The repair is beyond the scope of the operator, please call Comcater service to organise a technician.
	Pilot lights, but will not stay lit	When the pilot is lit, the flame is good, but the pilot won't stay lit, or drops out during service.  The repair is beyond the scope of the operator, please call Comcater service to organise a technician.

For all technical queries regarding troubleshooting please contact Comcater Technical Support:  
**Phone:** 1800 810 161 **Email:** techsupport@comcater.com.au



