

THE QUIETEST COMMERCIAL BLENDER AVAILABLE

The ultimate blender with unparalleled sound reduction, exceptional beverage blends, and improved speed of service.

SMART PRODUCT DESIGN

- Up to 4 times quieter than the competition due to the advance vibration dampening technology; resulting in quality drinks in a more enjoyable atmosphere
- Magnetically secured floating sound enclosure is dramatically easier to clean and disassemble with no screws to damage the enclosure
- 6 program buttons with 34 optimized programs for easier, consistent blending
- Advance® container creates faster, smoother pouring and has a longer blade life resulting in time and cost savings along with improved customer experience
- Air management and powerful ~3 peak output HP motor reduces noise, improves reliability, and reduces down time

STANDARD FEATURES:

- Advance Blade
- 1.4 litre high impact clear container
- 6 program buttons with 34 recipe programs to choose from
- 1-100 speed settings
- Pulse switch
- Automatic blend completion
- Sound reducing cover

PACK INCLUDES:

The Quiet One® with 1.4 litre high-impact, clear/stackable Advance® container complete with Advance blade assembly and lid, and removable compact enclosure.



Three year parts and one year labour warranty on motor and base. One year warranty on the container, lid, blade assembly, drive socket and sound enclosure against defects in material and workmanship.

DIMENSIONS

On-Counter: 216W x 272D x 457H mm (Cover closed)
216W x 336D x 622H mm (Cover open)

TECHNICAL DATA

Power Supply: 240V, 50Hz, 10A
Power Output: 1300W-1500W
Motor: ~ 3.0HP
Weight: 9.0kg

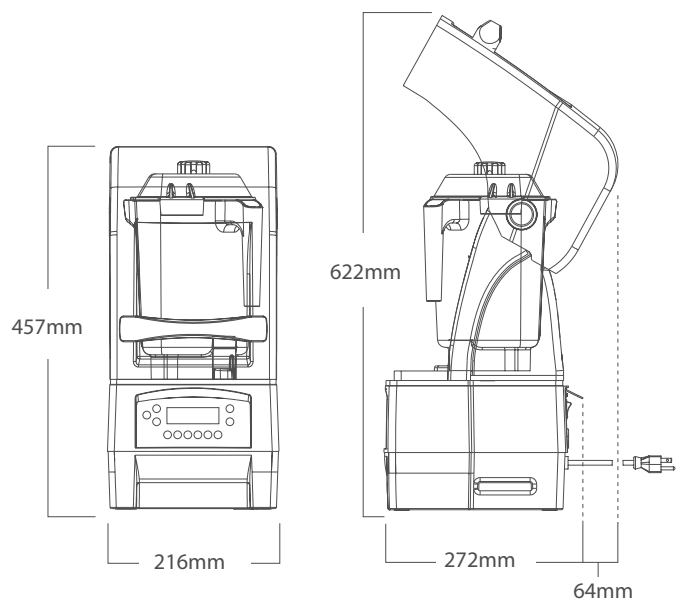

SPECIFICATIONS ARE SUBJECT TO CHANGE WITHOUT NOTICE.